



FEDERATION
INTERNATIONALE
DE L'AUTOMOBILE
WWW.FIA.COM

2026 FIA TCR World Tour Technical Regulations (Marked)

Articles : 1, 2.5, 2.6, 2.11, 2.15, 2.22, 2.24, 3.2, 3.3, 3.4, 3.6, 3.8, 3.9, 3.10, 4.1.3, 4.3, 4.4, 5.1, 5.2, 6.1, 6.2, 6.4, 6.5, 6.6, 7.2, 8.4, 9.2, 9.3, 9.3, 9.4, 9.4, 10.7, 10.10, 10.11, 11.3., 13.1, 14.4, 14.6, 14.8, 14.8, 14.13, 14.14, 15, 16.1, 18

ART. 1 GENERAL REMARKS

The WSC has developed the TCR technical regulations, of which it is the owner and promoter. WSC has granted a licence to the FIA to use these technical regulations and the Certification technical form for the competitions known as the FIA TCR World Tour and the FIA TCR World Ranking Final, both promoted by WSC.

It is reminded that WSC is the owner of the TCR brand and all related intellectual property of TCR. WSC is the exclusive owner of all TCR rights, including but not limited to those relating to organisation, marketing, television production and broadcasting, merchandising and sim racing.

Any manufacturer and/or engineering company interested in the construction and homologation of a TCR car should contact the WSC, TCR Technical Department. Contact: < technical@tcr-series.com >.

Then, he must comply with the specifications set out in article 1 of the TCR technical regulations

Unless otherwise defined in the present document, TCR Technical Regulations respect the following FIA rules:

- FIA App. J, Art. 251, 252, 253, 277
- FIA General Prescriptions applicable to International Series

The present regulations point also to the FIA App. J, Art. 255, 257A and 263.

All modifications which are not explicitly allowed by the present regulations are forbidden.
An authorised modification may not entail a non-authorised modification

ART. 2 DEFINITION

2.1 Bodywork

See App. J; Art. 251.2.5.2
Any air intake is considered to be part of the bodywork.

2.2 Chassis (Body shell)

The main body of the car into which is fitted the engine, transmission, running gear, electrical systems, seats, controls, bodywork, etc.

2.3 Production (part)

As fitted to the basic mass production car; the proof rests with the competitors.

2.4 Original part

As fitted to the WSC -certified car and in compliance with the TCR Technical Form.

2.5 Minimum Weight and Maximum Weight

Is the weight of the race car without driver as defined in each Technical Form, with empty tanks of consumable fluids (fuel, wind screen wash & drinking water, etc.) and with all other tanks filled at the working level. The minimum weight doesn't include ballast or non-compulsory equipment. that is not imposed by the regulation. (Certification)

Maximum Weight:

At any time, under no circumstances the maximum car weight can be over 1415 kg, with fuel, driver and any ballast.

2.6 Minimum Racing Weight

Is the minimum weight of the race car for every particular event and must be respected at any time during the competition. It is composed of the minimum weight of the car (Art. 2.5), the driver's weight with full compulsory

equipment (FIA Appendix L), the required ballast to reach the car's target racing weight (Art. 5.1 2.22) and all weight allocations for Balance of Performance (Art. 3.1 & 3.9).

Compensation Weight (Art. 3.9), and the Success Ballast (if stipulated by the individual sporting regulations).

Compensation Weight/Success ballast and any eventual additional ballast (in respect of the weight limit defined in Art 2.5) imposed by the sporting regulation are not included in the Minimum Racing Weight.

The Minimum Racing Weight will not include non-compulsory items like driver cooling, team camera, radio, etc.

The minimum front axle load proportion of the Minimum Racing Weight (measured with the driver and its full compulsory equipment – FIA Appendix L) is 59%, to be respected in any conditions during the event.

2.7 Cockpit

The interior volume of the main structure which is reserved for the occupants. Its limits are defined by the roof, the floor, the doors, the lateral parts, the glazed parts and the front and rear bulkheads (or the back plane of the rear seats).

2.8 Turbo Charging

Increasing the mass of the charge of the fuel/air mixture in the combustion chamber (over the weight induced by normal atmospheric pressure, ram effect and dynamic effects in the intake and/or exhaust system) using a turbo charger.

2.9 Location

A site defined relative to the production: centre line of the car, axles centre (middle of the wheelbase on the centre line), cockpit, luggage compartment, engine compartment, wheel arches or any other area of the car.

2.10 Position

The site defined by dimensions from the production car data, e.g., axles centre and centre line of the car. For position evaluation will be used a tolerance of ±5mm.

2.11 Telemetry

The wireless data transmission between a car and any device outside of it, the pit or to anyone connected with the entry of that car.

2.12 Mass Production

The Minimum Production requested for eligibility of car models and parts coming from other cars like engine, turbocharger, water cooler, intercooler, etc. is 5000 pieces / 12 consecutive months.

2.13 Model of car

All the identical cars belonging to a family (see below) and to a production series distinguishable by an identical conception and identical external general lines of the bodywork, and by an identical mechanical conception of the engine and the transmission to the wheels.

2.14 Family of car

Different series models belonging to one and the same production series of the same manufacturer.

2.15 Certification

The TCR Technical Form is the only official documentation of TCR Cars certified by WSC.

The TCR Technical Form is the compulsory document to take part in the FIA TCR World Tour.

The TCR Technical Form (version with QR code) must be presented for the entry and during scrutineering as individual and original document for each TCR Race Car. The TCR Technical Form is delivered by WSC as a personalised QR code (for each TCR Race Car). The Technical Form QR version can be requested by the entitled person at <<https://technicalform.wsc.group/>>.

Reproduction of the TCR Technical form in a whole or in part is prohibited. WSC reserves the right to withdraw the TCR Technical Forms, if any version of reproduction is found, and apply, if necessary, any fines or other penalties.

The Technical Form may have Extensions: Variant Option (VO), Supply Variant (VF), Erratum (ER), Facelift (EV: minor mid-life amendments) and Addendum (AD: additional information for previously certified parts), issued by WSC only. Starting from year 2023 (as replacement to the EV certification document used until end of year 2022), the TCR Technical Department will allow the Manufacturers and/or Authorised Engineering Companies can to certify the Evolution version (EV/EVO) of a specific TCR Car model. Details about the certification process and technical information are contained in the appendix document of this regulation "TCR-Certification_EVO.pdf" (available on the TCR Server).

The full list of official certified documents requested per each TCR car model "TCR CERTIFIED CAR LIST" is always updated by WSC and available in the TCR web area "TECHNICAL AREA", available for registered users, approved by WSC (link: <https://www.tcr-series.com/technicalarea#login>)

Any later extension document (VO, VF, ER, EV/EVO or AD) per each TCR car model can be downloaded by Competitors directly in the TCR web area "TECHNICAL AREA", once registered and allowed by WSC Ltd

Each TCR car model Extension document must be printed, presented by the Competitor and available to the technical delegate, attached to the original TCR Technical Form. This full set of documents is required during each Competition Scrutineering.

During the 1st season of a new car model development, it will be possible for manufacturers to apply for a Temporary Technical Form. Cars certified with Temporary Technical Form may be accepted on the grid by each TCR Promoter with WSC authorisation.

All WSC information regarding the certification process will be communicated by means of TCR Certifications documents (available on the TCR Server area):

TCR Technical Form is valid 7 Years after the stop of the series production of the basic model for the TCR race car. WSC may decide for prolongation per each car model.

WSC, as only authority allowed, defines a group of cars among the TCR certified cars: the "TCR Gen I" cars. The "TCR Gen I" cars are the cars identified in the below list (Table 1) with their Technical Form number and extension number released/certified by WSC before **31/12/2018**. Any later version is not considered as "TCR Gen I" cars.

MANUFACTURER	MODEL	TF #	TF Extensions
Alfa Romeo	Giulietta RF TCR	TF-022	Refer to Appendix A of this document
Audi	RS3 LMS DSG	TF-009	
Audi	RS3 LMS SEQ	TF-010	
Cupra	Cupra TCR DSG	TF-043	
Cupra	Cupra TCR SEQ	TF-035	
Honda	Civic FK2 TCR	TF-011	
Lada	Vesta TCR	TF-038	
Opel/Holden/Vauxhall	Astra TCR	TF-005	
Peugeot	308 Racing Cup	TF-008	
Seat	Leon Cup Racer	TF-017	
Subaru	WRX STI TCR	TF-007	
Volkswagen	Golf GTI TCR DSG	TF-012	
Volkswagen	Golf GTI TCR SEQ	TF-014	

Table 1

Starting from 10th December 2023, the TCR GEN I cars will be allowed to compete as per "TCR Notification Gen I Cars" Appendix A of this document.

TCR Gen I cars can be only licensed by WSC to each TCR Promoter and can be used as an independent grid or a Class inside another licenced TCR Championship.

TCR Promoter shall secure that these rules are respected by their Sporting Regulations.

3

2.16 OEM (Original Equipment Manufacturer)

OEM is a manufacturer of the mass-produced cars and the supplier of the original spare parts.

2.17 Reference Part, Component or Unit

Certificated part, electronic control unit or aggregate listed by WSC, which are deposited with the technical delegate and can be installed in the race cars on his decision at any time of the competition.

2.18 OEM Part

Component coming from any OEM mass produced car and in normal sale.

2.19 WSC Ltd.

WSC Ltd is the exclusive owner of the TCR concept, TCR Technical Regulations and all IP rights related to TCR

2.20 Catalogue Parts

Parts offered for sale as specified in the company's published commercial catalogues.

2.21 N/A

2.22 Target Racing Weight

It is the base car weight defined by WSC:

Target racing weight values:

- Sprint car with racing gearbox: 1265 kg with driver and his compulsory safety equipment.
- Sprint car with mass production gearbox: 1230 kg with driver and his compulsory safety equipment.

WSC / FIA reserves the rights to adapt these values.

is the basic weight of any TCR racing car with the driver on board and represents the Minimum Racing Weight (Art. 2.6) without any weight corrections provided by the regulation.

The current value is defined in Art. 5.1 of this regulation and by TCR Technical Bulletins.

The use of ballast to achieve the target racing weight is permitted in accordance with Article 5.1.2 of these regulations.

2.23	<p>Compensation Weight It is a weight ballast, based on an established allocation system calculated for each event (see FIA TCR World Tour - Sporting Regulations).</p>
2.24	<p>References Any topics with a double reference "WSC / FIA" are intended as "WSC and FIA", meant in common agreement.</p>
ART. 3	REGULATIONS
3.1	<p>Role of the WSC</p> <p>It is reminded that the basic principles of this competition, is customer oriented with regard to power to weight ratio and balance of performance (BoP).</p> <p>WSC undertakes to :</p> <ul style="list-style-type: none"> - Certifying TCR cars - Ensure, in collaboration with the FIA, the BoP at the start of the competition, and take all necessary decisions to maintain it throughout the racing seasons. <p>All FIA / WSC decisions concerning regulations will be communicated by means of TCR Technical Bulletins and TCR Notifications.</p>
3.2	<p>Eligible cars</p> <p>Eligibility criteria for TCR Car:</p> <ul style="list-style-type: none"> Only front wheel drive cars are eligible. The cars correspond to FIA Homologation Criteria for Touring Cars (FIA Group A). The model of car is produced by an OEM and belongs to a mass produced family. 4/5 doors Minimum length 4.2m Mono turbo charged 4 stroke petrol mass production Engines with cylinder capacity from 1750cm³ to maximum 2000cm³. Hybrid propulsion is not allowed. <ul style="list-style-type: none"> - Minimum length 4,2 m. - Front wheel driven. - Manufactured by a OEM with a minimum production of 3000 units per year. - Minimum 3 doors. - Maximum engine capacity 2500 cm³. - Hybrid not allowed. <p>WSC/FIA reserves the right to accept other cars, when the general characteristics match with the TCR concept. WSC/FIA reserves also the right to approve or to refuse applications which might not be in compliance with the above criteria.</p> <p>The Technical Form Number, the year of issuing and the certifying manufacturer will be documented on the WSC List, according to the TCR Certification Manual, respective Technical Form of each car model. The updated TCR eligible car list is published on the Technical Bulletins.</p> <p>Following definitions and procedures set out in Art.1 of the present regulations, in order to certify a new TCR car model, a Manufacturer and/or an authorized Engineering Company must produce a minimum of ten (10) racing cars in the 12 consecutive months starting with the date of the Application.</p> <p>Each selling order for new models of TCR racing cars must be processed within 3 months from the date of release of the TCR Technical Form by WSC and any sold cars must be delivered within 90 (ninety) days.</p> <p>Manufacturer and/or authorized Engineering Company must provide WSC within 3 months from the TCR car model certification with their TCR Car model brochure and spare part list, detailed with costs and delivery time. All these documents must be approved by WSC before publication. If the information received and ordering – selling time as per above are not satisfactory and not received on time, WSC has the right to withdraw the certification of that TCR car model without any further notice and the car model will be removed from the TCR Certified car list.</p> <p>The price cap for the complete, ready-to-use TCR race car is € 150,000 including the Scrutineering Data Logging System (including the TCR ECU Data USB Stick) with all mandatory sensors (see Art. 3.6 of the present regulation).</p> <p>In the event that a Manufacturer and/or an authorized Engineering Company with a new or an already certified car model shall not respect:</p> <ul style="list-style-type: none"> - The minimum production, - The order delivery time, - The price cap, <p>FIA/WSC reserves the rights to impose sanctions depending on the real situation like:</p> <ul style="list-style-type: none"> - Fines - suspension of further Technical Form Extensions - temporary suspension of the Technical Form until the imposed conditions are met

- revocation of the Technical Form.

3.3 Compliance with the regulations

All TCR cars must be conformed to these regulations, TCR Technical Form, TCR Notifications and Technical Bulletins.

All parts not mentioned in these regulations have to remain those from the basic production car or another production model of the same manufacturer and correspond to the Manufacturer's Parts Catalogue for the produced model and may not be modified in any way.

In case of doubt about the conformity of any part the Technical Delegate may ask the opinion of the car's manufacturer or request the replacement with a reference part without any further explanation. All cost of such operations will be covered by the Competitor.

Teams will deliver on request to the technical staff following information regarding TCR cars:

- Data from team's data logger
- Video footage from team's camera
- Any other technical documentation

Upon request, manufacturers will deliver to the technical staff any technical information regarding TCR cars.

FIA/WSC has the right to collect and archive all information regarding any TCR cars.

It is the duty of each competitor to assure the Scrutineers and the Stewards of the competition that his car complies with these regulations in their entirety at all times during a competition.

All costs of the technical checks will be supported by competitors.

~~A car, the construction of which is deemed to be dangerous, may be prohibited by the Stewards.~~

~~A car, considered to be built or repaired without meeting the safety criteria verified by the Technical Delegate may not be allowed to enter the session/event by the Stewards.~~

3.4 Measurements

All cars' measurements must be taken while the car is stationary on ~~the reference surface declared by the Technical Delegate, a flat horizontal surface in the location stated in the Sporting or in the Supplementary Regulations.~~

3.5 Material

Titanium or magnesium alloys, ceramic or exotic materials and sophisticated coatings are not permitted unless used for the production part or explicitly authorised by these regulations.

All flexible supports (engine, transmission, sub frames, etc.) may be replaced by stiffer brackets with same functional dimensions. If not otherwise defined by the present regulations the aggregate's position may not be modified. (Certification)

External bodywork parts may be repaired by adding material respecting the certified properties (minimum weight, functional shape, etc.). Such operation needs the approval of the technical delegate.

Any mechanical elements specified by mass catalogues for threaded fixations (e.g., bolts, studs, nuts, washers) may be freely used in respect of these regulations, maintaining the material, to assemble and correctly adjust different parts.

3.6 Data logging

The car must be fitted with the scrutineering data logging system providing following data (Certification):

- Speed of the 4 wheels
- Engine revs & timing
- Longitudinal acceleration
- Lateral acceleration
- Throttle pedal position
- Throttle valve position and of any other control element
- Engine load target & delivered Engine load (if the Throttle Valve doesn't follow the Throttle Pedal Position)
- Engine Water Temperature
- Inlet air temperature in the manifold
- Boost pressure (monitored by an additional sensor)
- Front & Rear Brake Calliper pressure
- Lap trigger
- Lambda-signal
- Ignition angle timing
- Injection duration, start & end
- injection fuel pressure
- camshafts timing & positions
- GPS (TV or radio antennas must be at least 30cm away from the official GPS antennas. If necessary, antennas will be moved to guarantee correct GPS signal.
- Steering wheel angle
- Launch-control button
- Gear position

FIA / WSC will decide and communicate the list of stand-alone sensors or of other independent monitoring systems for each model. (Certification)

For cars not using the TCR ECU:

The certified Scrutineering Data Logger system consisting of an a “Memotec” evo4 or evo5 box and a TCR kit (specific bracket, sensors and loom) must be installed corresponding to the instructions.

Manufacturers must offer for sale race cars equipped with scrutineering data logging system.

The collected data remains property of FIA and WSC.

The scrutineering data logger may not be used as Team Data Logger and may not be accessed by the team. On request, competitors receive recorded data of their own scrutineering data logger, to verify own sensor values.

For cars certified with TCR ECU the Scrutineering Data Logger is integrated in Engine TCR ECU and may be used as Team Data Logger. Fitting instructions for scrutineering data logger and basic configuration file for the integrated logger containing all official channels is provided by WSC Technical Department. Manufacturers are not allowed to remove or modified scrutineering channels, but they may use logged data and add their own channels to the configuration.

Only cars using the Engine TCR ECU may use the official air temperature sensor from the Scrutineering Data Logging System for the engine management.

The use of Team Data Logger is allowed for all cars. The Team will allow access to the Technical Delegate to the data of Team Data Logger at any time.

Team Data Logger with removable memory devices are allowed.

The use of following sensors is not allowed:

- Pitot tube
- Tire pressure
- Tire internal and external temperature including the running surface
- Non-contact ground distance sensors (Suspension travel potentiometers are allowed)
- Inertial platform
- Turbine speed
- Combustion pressure
- Sensors using wireless data transmission
- Engine torque sensors
- Load cell on power train, running gear and suspension mounting points.
- non-contact sensors (temperature, distance, optical car speed sensors, dedicated yaw sensors, etc.)

Allowed Sensor Technologies:

- Electric-resistor-based sensors with direct contact to the measured item
- MEMS (micro electromechanical systems) sensors
- GPS up to 50Hz
- Magnetic field sensor
- Pressure sensors based on membrane technology
- Mass Production Sensor Cluster

Not Allowed Sensor Technologies:

- contactless distance and temperature sensors
- DGPS (Differential Global Positioning System)
- Piezo technology (exception: engine knock sensor)

3.7 Telemetry

The use of telemetry is forbidden.

3.8 Driving aids

Driving aids are not permitted.

If the race car using mass production engine management cannot be operated without the Driving Aids, the mass production systems including mechanical parts and Electronic Control Units [Anti-lock Braking System (ABS), Electronic Stability Program (ESP) & Traction Control System (TCS) not included] may be used on condition that the original hardware and software are maintained (only changes to the wiring are permitted). It is not allowed to the driver sitting in the car to change settings while the engine is running. The systems may be also switched off or removed (Certification).

Brake bias adjuster with display can be authorised (Certification)

The pit speed limiter and the launch control (as described below) are permitted. For the launch control 1 (one) additional engine rev-limiter is allowed. The rev-limiter is activated and stopped by the driver and is constant during the launch control phase. There is no closed loop control considering engine revs, wheel speed and clutch actuation allowed.

Other constant rev-limiter(s) is (are) permitted for imposed speed limits (pit speed, virtual safety car, circuit sections with speed limit, etc.). (Certification)

3.9 Balance of Performance (BoP)

All Manufacturers must communicate ~~the requested specific numbers for the definition of the numeric model~~ any data requested by FIA/WSC for the BoP evaluation.

Manufacturers will present certified TCR cars at all BoP tests sessions at TCR invitations.

Parameters which may be modified for BoP at any time of the season:

- Minimum Racing Weight. ~~(upper limit is 1365 kg).~~
- Engine performance level implemented by monitored electronic components (90%, 92.5%, 95%, 97.5%, 100% and 102.5% named level "1" to "6")
- Smaller boost pressure steps implemented between the aforementioned engine performance levels
- Minimum Ride Height
- ~~Compensation Weight (CW) calculated with automatic formula communicated by Technical Bulletin.~~

All engine performance relevant parameters will be monitored related to engine speed according to methods defined by Technical Bulletins and TCR Technical Notifications.

3.10 Period of Certification

WSC will release 1 (one) Technical Form per model frozen for 3 (three) years starting from the date of the final certification.

Each Competitor must have at the scrutineering the original TCR Technical Form (QR code) for each car.

~~Face lifts are not considered as new cars. It will be possible to change only the modified body shell parts on the production car.~~

~~Technical Form's modification will be allowed during the season only for following reasons:~~

- Safety
- Reliability
- Obvious lack of performance
- Allowed Variant Options

ART. 4 BODYWORK

4.1 Chassis (Certification)

The chassis cannot be modified unless permitted by the present regulations.

All chassis modifications including the removal of unused supports have to be certified in the Technical Form.

Following condition must be respected:

- Width of bodywork: Maximum 1950mm
- All chassis modifications have to be approved by WSC.
- If not otherwise defined by the present regulations any non-movable element must be attached with the use of tools.
- Wheel arch modifications allowed, for the sole purpose to accommodate race tyres.
- Front bulkhead may not be modified except for a modified passage of the gearshift control, electrical loom(s), brake lines, fuel lines and extinguisher lines.
- No modification of McPherson turrets except of local reinforcement following the original shape and through metal ribs or fins as connection between turrets and front bulkhead for strengthening of strut mounting area. Production reinforcements and openings may be locally reworked without weakening the structure to allow access to the strut.
- Seam welding replacing or reinforcing production part spot welding is authorized.
- Local modifications of the chassis or sub frames are permitted to provide clearance to the exhaust system, transmission and suspension.
- Temporarily removal of the roof outer skin is permitted only to allow the safety cage's correct installation.

Sub frames may not be modified for the fixation on the body shell or for the attachment of suspension elements. All sub frame modifications have to be approved by WSC. Reinforcements and the removal of unused supports are permitted. (Certification)

Strengthening of the suspended parts of the chassis / body shell through the addition of parts and/or material is allowed under the following conditions:

The shape of the reinforcing part/material must follow the surface of the part to be reinforced, having a shape similar to it and the following maximum thickness, measured from the surface of the original part:

- 4 mm for steel parts.
- 12 mm for aluminium alloy parts.

Stiffening ribs are allowed but the making of hollow sections is forbidden.
The reinforcing part/material must not have any other function than that of reinforcement.

Passage for the gearshift control: Local modifications are authorised.

Mountings and bearings of antiroll bars: The main rails may be modified to integrate the anti-roll bar bearings. The new mountings of the anti-roll bars must not have any other function.

Mounting of pedal box and master cylinders: Modifications are authorised provided they have no other function than to allow the fixing of the master cylinders and/or the pedal box.

Central tunnel and/or floor on the driver's side to allow Driver's seat installation for correct driver's position:
Local modifications to the central tunnel and/or the floor on the driver's side are authorised with no other purpose than correctly installing the compulsory racing seat according to this regulation.

Panel on top of fuel tank area for Fuel tank ancillaries' installation: Local modifications of the area situated on top of the fuel tank are authorised with no other purpose than creating a flat surface to install fuel tank ancillaries.

Holes or openings on the production body-shell placed in areas not licked by the airstream may be permanently or temporarily closed (plugs, welded or glued covers, tapes or similar).

4.1.1 Bonnet and boot lids

It must be possible to open them without use of tools.

The retaining springs (not the hinges) may be removed, but the car must have supports to hold the bonnet and the boot lid in open position. (Certification)

Openings in the engine bay bonnet are allowed up to a maximum total surface of 1050cm², including any original opening(s) but must be covered by wire netting with maximum mesh surface of 500mm² (Certification). Trims on the openings can be added to the bonnet provided that they do not protrude from the outer surface more than 15mm outwards and 50mm inwards (Certification). Cut-outs in the original production bonnet for the trims are allowed up to a total surface of maximum 2350cm² including any original cut outs. The production internal reinforcements may be removed in the opening zone. (Certification)

4.1.2 Doors

The production door locks, door-hinges, anti-intrusion bars, external door handles must be kept and in the original position.
It must be possible to open all doors from outside (original handles) and the front doors also from the inside.

All the side windows must be original.

The passengers side window lifters may be removed but must be locked in place and secured from all movement.

The removal of door soundproofing material and decorative strips is allowed.

Original inner trim panels must be replaced and be made from plastics (including composite materials) at least 1mm thick.
The panels must totally cover the door, its handles, locks and window winding mechanisms.

Air inlets for cockpit cooling, making a hole on the body of the external mirrors are accepted. (Certification)

Internal ducts displacement and orientation are free, as much as the visibility and/or the safety of the driver is not compromised.

4.1.3 Engine & Luggage Compartments

The soundproofing, decorative, insulating material and parts may be removed. (Certification)

4.2 Windscreen and windows

The use of the mass production windscreen is permitted.

The use of electric heated glass windscreen of artisanal production is allowed. (Certification)

Plastic windscreen (polycarbonate or PMMA ensuring the same transparency as the original glass) with the same shape of the reference part, with or without heating with minimum thickness 5.85mm is allowed. (Certification).

Anti-intrusion arm(s) or support(s) for Plastic Windscreen may be used. (Certification)

The addition of a maximum of 4 protective transparent films on its external face is permitted.

The original heating system may be removed but a demister system must be installed. (Certification)

Plastic rear window min. 3.85mm is allowed. (Certification)

The internal face of side and rear glass windows as well as the glass rear-view mirrors must be covered with a transparent and colourless plastic safety film with a maximum thickness of 0.1mm in order to avoid the shattering and spraying of glass in the event of an accident. It must be fitted in a manner that facilitates checking.

4.3 Exterior

Bodywork - General

A maximum of 3 holes (maximum diameter of 12.5 mm) are permitted for the team in order to use supplementary measuring devices (radio, temperature, pressure, and similar). Other up to 4 similar holes are allowed for promoter use.

If a device is not used during a competition, the corresponding hole must be sealed off and the exterior of the bodywork must retain its original appearance.

The only body parts that can be replaced and changed in shape are (must be approved by WSC prior to production):

- Front bumper: Shape resembles the original without bolted license plate support(s). must be approved by WSC prior to production; no dive planes allowed.
- Front fenders' lower edge behind the wheel may not be higher than front door's bottom border. Shape must be approved by WSC prior to production no louvres allowed.
- Side sills (these may be added if not present in the production car)
- Rear wheel arch extensions. Shape must be approved by WSC prior to production.
- Rear door bulge compatible with the rear arch extensions
- Rear bumper:
- Shape resembles the original must be approved by WSC prior to production.
- Wheel arch liners

No flat floor behind the vertical plane tangent to the back side of the front wheels and the foremost point of the rear bumper. Engine bay protection panel between the frame rails is permitted. (Certification)

It is not allowed to tape the joints or use self-made gaskets (foam, rubber, etc.) between bodywork panels or parts. The hood's and boot lid's original position may not be changed.

Door and bonnet seals may be removed.

Installation of air jacks

The bodywork may be modified over a maximum area of 100 cm² to create housing for the air jack connector.

The connector for the feeding of compressed air must be situated rearward of the rear axle centreline and must not protrude beyond the surface of the bodywork.

Roof Hatch installation without structural parts' modification for access to the cockpit is mandatory for cars certified after 01/01/2026 permitted. Refer to Appendix J Art. 257A. (Certification)

Air inlets for driver cooling on the roof are accepted with the following conditions (Certification):

- only NACA inlet and duct is accepted and must not protrude (externally) from the roof profile.
- Position: between A and B pillars.
- Max. area of the NACA inlet projection: 250cm².
- Roof Hatch functionality must not be compromised.
- Cooling ducts to the driver are free: they must not compromise the visibility and/or the safety of the driver.

The use of mesh in air inlets without changing car's external appearance is permitted.

4.4

Aerodynamic devices

Rear wing with brackets (Certification)

The original car's devices must be removed and must be replaced with one compulsory rear wing made up of:

- One aluminium extruded wing profile (WSC delivery corresponding to the profile defined below)
- Specific part produced following exactly the WSC rear wing dimensions and functions
 - Material: aluminium or fibre reinforced plastic
 - Production drawings corresponding to the WSC 3D model will be delivered for certification.
 - The angle adjustment will use 1 (one) axis of rotation. (For cars certified after 2019)

Rear wing definition & Dimensions:

- Straight, adjustable, single piece with no flap
- Type BE 183-176 +/- 1.5mm
- Chord = 250 +/- 1 mm
- Width = 1380 +/- 1 mm
- Trailing edge thickness = 2mm -0/+1.5 mm

The original car's aero devices must be removed. Only one of the two TCR approved rear wings assemblies (as defined below) can be used.

Option 1:

- BE profile, as defined below (Drawing 1A)
- It must be straight, adjustable, and composed by a single piece with no flap
- Material: aluminium or fibre reinforced plastic.
- Wing profile position can be tuned using only one angle of rotation.

Definition & Dimension

BE profile

Type	BE 183-176 ± 1.5 mm
Chord	250 ± 1 mm
Width	1380 +0/-1 mm
Trailing edge thickness	2 -0/+1.5 mm

Be 183-176 Ro = 2.69 Xo = 2.69 -Yo = 2.79

x %	0	1.25	2.5	5	7.5	10	15	20	30	40	50	60	70	80	90	95	100
-Yv	2.79	0.53	0.07	0.1	0.62	1.32	2.86	4.35	6.79	8.8	10.02	11.4	11.95	11.8	9.03	5.58	0.1
-Yo	2.79	7.31	9.4	12.52	14.95	16.94	20.05	22.3	25.01	25.98	25.65	24.39	21.44	17.43	11.43	6.63	0.2

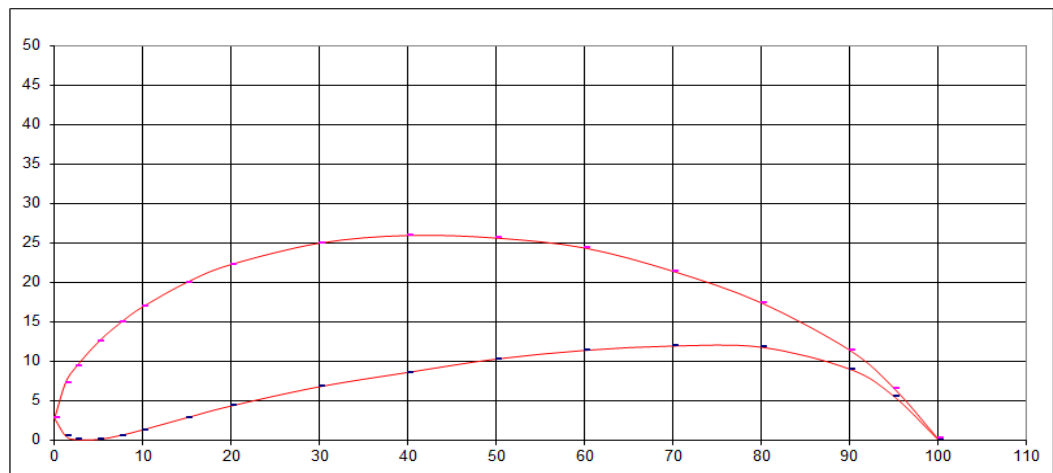

DRAWING: 1A

Option 2:

- Cupra/ V W part number 5F6.827.939.C (Drawing 1B)
- Wing profile position can be tuned using only one angle of rotation

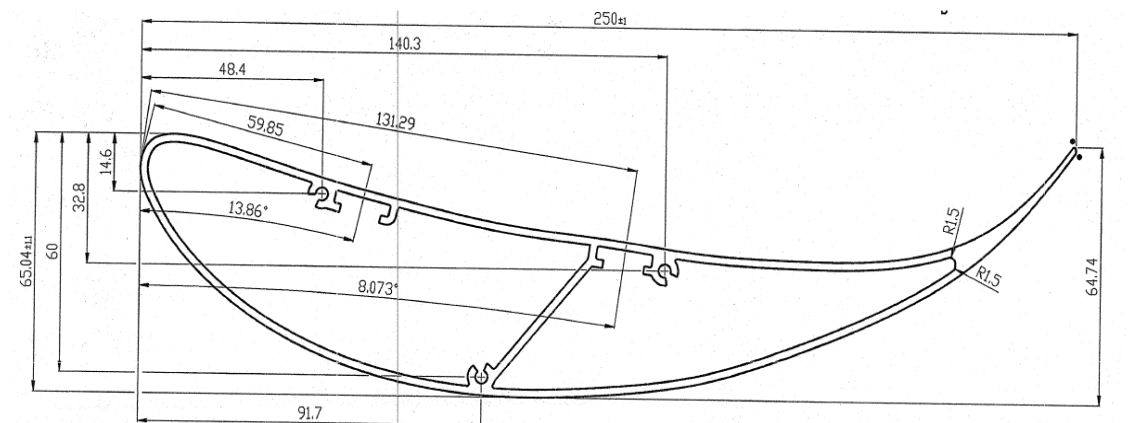

DRAWING: 1B

2 Brackets

Dismountable, flat, plane surface perpendicular to wing profile surface.
 Mounted on the boot lid or on the rear window and to the lower or to the upper wing profile surface.
 Min. transversal distance between both supports and between supports and side plates = 100mm.
 The leading edge must be rounded with a constant radius.

The trailing edge may be chamfered to a max. of 20 mm (min. thickness at the trailing edge = 2 mm).

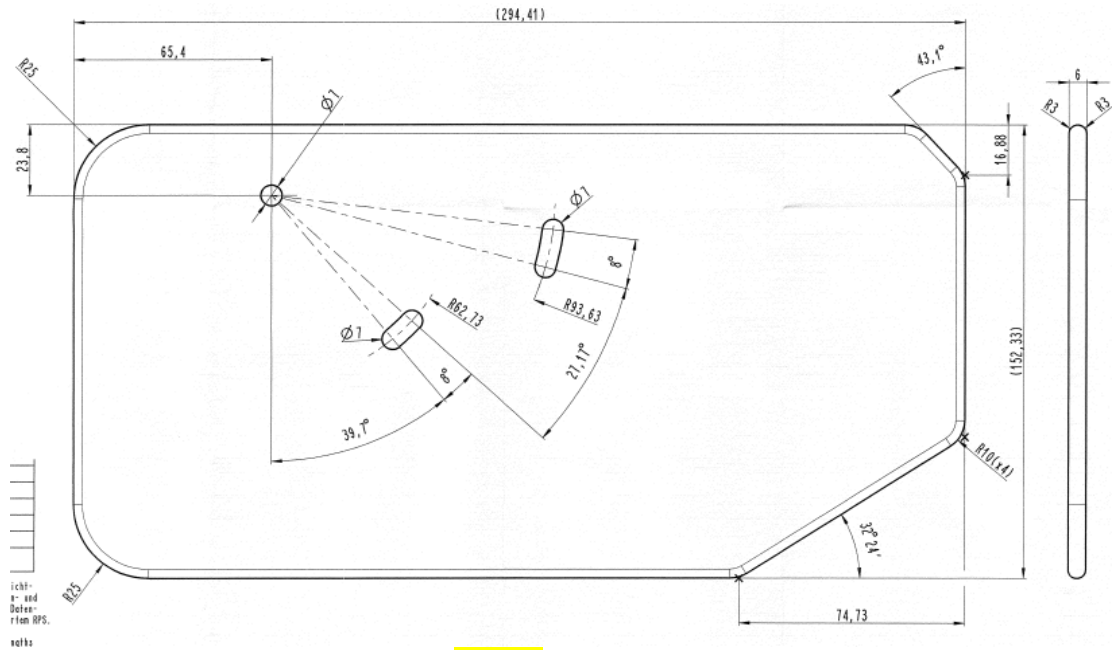

Drawing 2

- 2 side plates (WSC delivery or Specific parts Drawing 2); All edges will be rounded with at least R3mm (Safety)
- Dismountable, flat, continuous surface perpendicular to profile centreline.
- Side plates may rotate with respect to the wing profile.
- This device must be rigid and offer no possibility for the penetration of air (groove, hole, opening, etc.).
- Material: aluminium, plastic

No element of the rear wing including side plates and brackets may be located beyond the following limits, at any time during the event.

- X = 1050 mm from rear axle centreline.
- Z = Highest point of roof.

The front splitter (Certification):

- WSC delivered and adapted to each car; It will also be possible to reduce the front splitter's protrusion into the wheel arch in case of collision with the front tire's enveloping curve.
- Specific part following exactly the WSC CAD model for front splitter's dimensions (length, width and angles, front overhang, vertical projection, sections of areas touched by the airstream) (see Drawings) must be aligned with the drawing 4:
 - lateral prolongation in "x" for cars with bigger front overhang is allowed (max. width in "y" 50mm)
 - The distance between splitter's contour vertical projection and bumper contact area on the front splitter is limited as follows:
 - In the middle area ($y = \pm 400$ mm) will be between 35 and 85mm.
 - Outside $y = \pm 400$ mm is limited to max. 210mm.
 - In the transition area to the wheel arches is limited to max. 45 mm.
 - The layout of the areas covered by the bumper is free.
 - The areas next to wheel arches may remain flat.
 - production drawings will be delivered for certification
 - material: fibre reinforced plastic
 - Scrutineering shape jigs for external contour, leading edge and lower face will be delivered on WSC request.
 - WSC may approve justified waiver.
 - Note: in case of doubts, the WSC CAD 3D model overrides the drawings.
 - 2 embedded skid pads, Steel, 1.2 ± 0.1 mm; max. Area: 600cm² each (shape and fixations are free, Certification on Technical Form or VO)

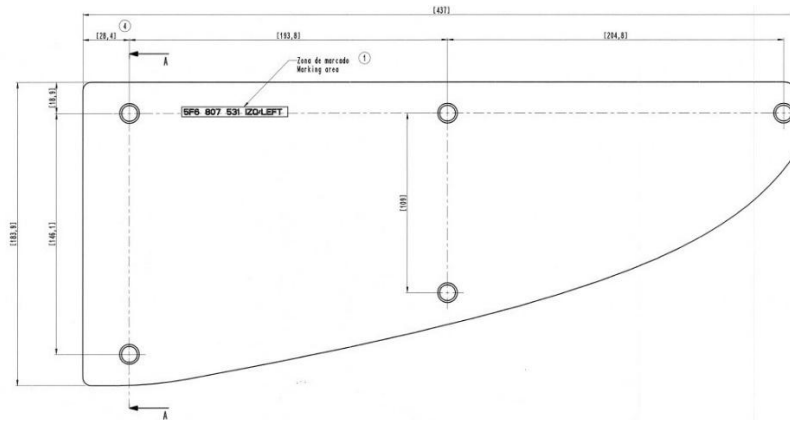

Drawing 3

The foremost edge of the front splitter at y=0 will protrude the bumper contour by max. 35mm in vertical projection. Front Splitter Brackets' design is free however the front splitter must be rigidly fixed the car's body at least in the area between the vertical projection of the front side members extended in X direction to the car's front end. Outside this area flexible front splitter mountings are allowed. (Certification)

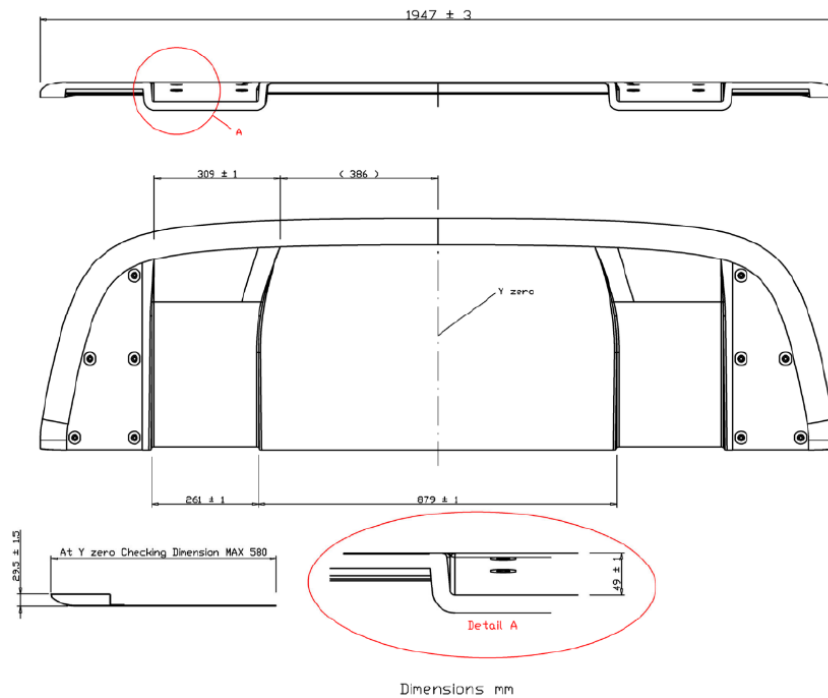

Drawing 4

Rear diffuser included in the rear bumper: (Certification)

- One single plane between a vertical plan minimum 380mm behind the rear axle centre line and the bumper's vertical projection
- Open downwards hollow area for the exhaust end pipe(s) allowed
- Maximal width: 1650mm
- Max inclination to the doors' lower edge: 25°
- No air circulation over the diffuser
- Fins or other air guiding surface are not allowed.

Mass production flexible skirts reducing the ground clearance may be removed. (Certification) The ground clearance check will consider these parts as bodywork

4.5 Interior

Dashboard trims; Centre console

Trims situated below the dashboard and which are not parts of it may be removed. It is permitted to remove the part of the centre console. (Certification)

Dash board (Certification)

- General shape, appearance, mounting points and position must remain similar to production part.

- Thermoplastic or Fibre Glass plastic materials are free.
- Minimum weight: 2kg including ducting and fixation elements.

Instruments (Certification)

Display and indicators can be freely fixed on the dashboard or to the steering column. The installation shall not interfere with the driver's vision or safety. A single additional display may be used only for lap live time delta and/or prediction.

Switches (Certification)

Standard switches may be replaced by other control elements and may be fitted at different locations on the dashboard or on the centre console. Any opening resulting from this must be covered.

Allowed switchable functionalities affecting engine ECU on the steering wheel or switch panel(s) while engine running (allowed positions are on/off): Full Course Yellow, Pit Speed Limiter, Launch Control, GBX neutral and reverse gear. If switches (e.g., rotary, flip, button) for all other functionalities are placed in driver's reach, these may be activated, and parameters of the engine ECU functionalities may be changed between certified parameter sets or within allowed software variants only when the engine is not running. It must be verifiable by checking engine ECU calibration and from logged scrutineering data, that switch actuation for these purposes does not take effect while engine is running.

Production Pedal Box: metallic pedals may replace the production plastic parts. New master cylinders and new arrangement in the engine bay may be used. (Certification)

Racing pedal box from shelf (hanging or floor mounted) and master cylinders in the cockpit: Modifications are authorised provided they have no other function than to allow the fixing of the master cylinders and/or the pedal box (Certification).

The original heating & air condition systems may be removed. Bulk head openings must be closed respecting "fire-wall" conditions. (Certification)

The wind screen demisting system is mandatory. Mass production AC & Heating Systems may be removed. (Certification)

ART. 5 WEIGHT

5.1 Target Racing Weight

The target racing weight for cars using racing gearbox is 1,265 kg.

The target racing weight for cars using mass production gearbox is 1,230kg.

The minimum front axle load proportion is 59% to be respected in any conditions during the event.

5.2 1 Ballast, Success Ballast

Ballast, including success ballast, must be made from metallic plates or blocks and must be fixed in the cockpit and/or in the boot. It is permitted to complete the weight of the car with ballast.

The metallic blocks or plates must be fixed by means of tools, with the possibility of affixing seals.

The ballast must be attached to the body shell/chassis with bolts of at least 8.8-class with a minimum diameter of 8 mm, with counter plates, according to the principle of the following Drawing.

The minimum area of contact between body shell /chassis and counter plate is 40cm² for each fixing point.

Any movable ballast system is forbidden.

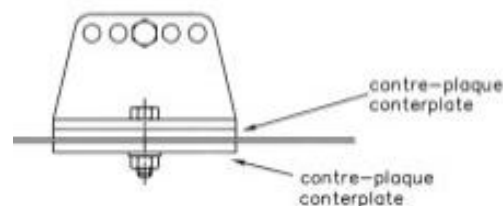

Drawing 5

The ballast and success ballast will be declared as such at the scrutineering. The success ballast must be marked and it must be possible to remove separately.

The ballast fixing system must allow to the Technical Delegate to seal the bolts. The ballast must be designed such, that tools are required for its removal.

5.3 2 Liquids

The race car's weight may be checked at any time during the competition, including Qualifying and Races, with the existing quantity of liquids in the tanks. At any other technical check, outside the time defined before, the technical delegate may verify the race car's weight with emptied consumable liquid tanks.

ART. 6 ENGINE

6.1 Engine generals

Turbo charged mass production engines without modifications.

- The make and type of the spark plugs with the corresponding gaskets (if any) must be certified. The Engine Calibration Certification Test must be performed with the certified spark plugs and spark plug gaskets.
- It is allowed to change the injectors with OEM parts similar dimensions. (Certification)
- The mass production high pressure fuel pump from the TCR certified engine cannot be modified. (Certification)
The electric loom and connection(s) may be modified to improve durability. (Certification)
- Cylinder head gasket may be changed with another one with identical dimensions. (Certification)
- All crankshaft bearings may be changed with another one with identical dimensions. (Certification)

Engine position: Production; The crankshaft's axis within a cylinder with R=20mm

The use of a different standard engine coming from another mass production car of the same group or of the TCR Race Engine is allowed. (Certification)

Position of the replacement TCR engine in engine bay (Certification):

- The crankshaft's axis will be within a cylinder with R=20mm relative to the position of the original engine in the production car of the TCR model.
- The inclination (defined by the cylinder sleeve axis) corresponds to the inclination of the replacement engine in its original car.
- The y-position is free for TCR models with transversal engine.

Only sealed engines by the manufacturers are eligible for TCR Events. (Certification)

Additionally, the engine must be prepared in such a way that the technical delegate is given the possibility to seal the oil sump and the cylinder head cover. (Certification)

It is not allowed to put ice or any other cooling system in the intake pipes or in front of the intercooler.

Indicative Engine Performance (ECE-R 85-5 Norm):

- Maximum Torque around 410Nm
- Maximum Power around 340HP

6.2 Engine Cooling

Intercooler

Mass production intercooler from another OEM (maximum core volume 8 litres) may be used (Certification).

Air Ducts: free between air inlet and intercooler core (Certification)

The position and brackets are free without any modification of the bodywork. Air hoses and water pipes are free (Certification)

Water Cooling

Radiator: mass production part free provided that the radiator is fitted in the production location without any modification to the bodywork (see exception below), brackets, water hoses and water pipes are free (Certification)

Thermostat: free (Certification). The use is optional.

Electric & mechanic fans for radiator cooling: free (Certification on Technical Form or as VO)

Air Ducts: free between air inlet and cooler core (Certification)

In justified cases, Manufacturers may apply for removal or modifications of the upper radiator cross members without negative effects for rigidity of the chassis structure (WSC approval and Certification).

Engine oil cooling

The type of the used oil cooler (air/oil radiators or water/oil heat exchanger) and their connections are free. No modifications to the bodywork are allowed. The parts have to be situated within the perimeter of the bodywork in safe position. (Certification)

An additional oil cooler may be certified with a VO (Variant Option), without any modification to the bodywork.

It is allowed to put tape in on the grilles air inlet of the front bumper to regulate the engine water and oil cooler temperature (in car colour).

Only ambient air may be used for heat dissipation.

6.3 Lubrication

Following is allowed:

- Pressure accumulator (Certification)
- Baffles and deflectors in production oil wet sump; The distance between the planes of the oil sump gasket on the engine block and on the oil-sump may not be increased by more than 6mm. (Certification)

If the lubrication system includes an open type sump breather, it must be equipped in such a way that the oil flows into a catch tank. (App. J, Art. 255. 5.1.14)

6.4 Engine control unit

If the car's Power Box communicates to the engine, its software must be certified on the programming code level, identifiable and frozen. (Certifications)

Anti-Lag System is forbidden.

Every manufacturer will have to provide 6 (six) engine mappings with differing power outputs: 90%, 92.5%, 95%, 97.5%, 100% and 102.5% named level "1" to "6" (Certification).

For cars certified until end 2019:

The choice of the engine Electronic Control Unit (ECU), engine control software, sensors and engine loom are free. (Certification)

The software and all data sets are frozen and cannot be overwritten. ECU box will be sealed by the Manufacturer and the access to modify software and parameters will be closed to prevent manipulation.

~~Manufacturers will deposit on request by the technical delegate free of charge for the duration of participation of their cars to the FIA TCR World Tour Engine Electronic Control Unit(s) (ECU) for all registered engine performance level(s) defined for BoP purposes.~~

~~The Technical Delegate may at any time oblige the competitor to use the reference unit registered with the WSC by the Manufacturer.~~

Any manipulation, modification or disconnection of any certified sensor is forbidden. The Competitor is responsible for the quality of the sensor signals.

The software and the map(s) for the all certified engine performance level(s) are frozen and cannot be modified without WSC agreement. (Certification)

Every manufacturer has to provide software tools (free of charge and without limitations concerning the required number of copies and licenses) to allow for the Technical Delegate to monitor the engine control software. The interface cable, that is needed to access the engine control unit while it is installed in the car, has to be provided for the Technical Delegate by all participating competitors free of charge. The engine control software and the datasets have to be provided in a binary format to the Technical Delegate by the manufacturer.

The software tools have a minimum functionality of:

- Upload/Download program software and data sets
- Calculate Checksum of program software and datasets after uploading them

Car certified from 2020 onward

The TCR ECU (Marelli, model: SRG-141) must be ordered from manufacturer and used as is, i.e., no modifications to the base software of the ECU are allowed. The TCR ECU must be mounted as specified in the "TCR-Certification_TCR-ECU-Installation-Manual", available on the TCR Server.

Detailed specification of requirements for the 6 mappings can be found in WSC BoP documentation (Document "TCR-Certification_Engine-Dyno-Test-Guidelines). Power levels will be selected via the TCR Power Level Rotary Switch delivered on order by Marelli and will be sealed by the technical delegate following BoP Table.

The ECU will act as a scrutineering data logger for the Technical Delegate. Software licenses are provided by Marelli. Hardware interface, i.e., connector with correct pinout to connect a laptop via Ethernet (RJ-45) must be provided by each manufacturer using the "TCR-Certification_Engine-Dyno-Test-Guidelines" Document. from Marelli.

6.5

Intake system

One (1) supplementary opening in the front bumper without protrusion above bumper's exterior surface can be made. (Certification)

The maximum boost pressure will be defined during BoP test. The boost monitoring procedure is described in the latest version of the document "TCR-Notification_Boost-Monitoring-Method". ~~(refer to Art.18).~~

The air filter housing and the air filter element may be replaced with a catalogue part (Certification). The air feed pipes to the air filter housing and from the filter housing to the turbo are free. (Certification)

1 (one) different mass production Mono Turbo Charger **including its wastegate valve** coming from engines with cylinder capacity smaller than ~~2000~~ **2500** cm³ may be used. (Certification)

It is allowed to change the impeller in case the Turbo Charger is integrated in the exhaust manifold. (Certification)

The turbo charger must be sealed by the manufacturers and must have the possibility to be sealed by Technical Delegates. (Certification)

No fresh air connection pipes between inlet and exhaust manifolds are allowed. Antipollution air circulation parts have to be removed and the connection ports must be closed. (Certification)

6.6

Exhaust

The exhaust system is free downwards the turbo charger and its regulating system. It will fit FIA homologated catalytic converter(s) (FIA List no. 8), will have nominal wall thickness minimum 1.2mm and will have the exit(s) at the car's rear end below the rear bumper. (Certification)

If a different turbo charger is certified an adapter between this and exhaust manifold may be used, (Certification).

The sound level must not exceed 110 dB(A) at ¼ of maximum revs, measured in conformity with the FIA noise-measuring method (see Article 252-3.6 of FIA Appendix J).

	Manufacturers may apply for option (VO) for exhaust muffler system for low noise circuits. (Certification) Certified parts may be used following events specific noise limit.
6.7	<p>Fly-wheel assembly (Certification)</p> <p>Flywheel: production part or modified respecting following conditions:</p> <ul style="list-style-type: none"> - Fly wheel can be re-manufactured solely to allow for a replacement clutch. - Minimum weight 6kg (without fasteners) - Machined from a single block of steel (no weight reduction bores, pockets or cut-outs) - The starter gear must have same or bigger dimensions.
ART. 7	FUEL SYSTEM
7.1	<p>Fuel tanks</p> <p>The fuel cell(s), the filling and ventilation systems must be separated from the cockpit by a fireproof and liquid-proof protective device and must comply with FIA App. J, Art. 253. (Certification)</p> <p>The total fuel volume in the car is max. 100 litres (Certification).</p> <p>Designs have to be WSC approved before implementation.</p> <p>Technical and design conditions:</p> <ul style="list-style-type: none"> - The fuel tank must be conformed or exceed the specifications of FIA/FT3 1999, FT3.5 or FT5 and comply with the prescriptions of FIA App. J, Art. 253.14 - The fuel tank must be contained in a close-fitting flameproof and liquid-proof lower (external) housing that has no other mechanical function including a crushable structure on all surfaces except the one in contact with the body shell. - The crushable structure must be a honeycomb sandwich construction based on a fire-resistant core of a minimum crushing strength of 18N/cm². The sandwich construction must include two skins of 1.5 mm thickness having a tensile strength of minimum 225N/mm² and must have minimum thickness of 10 mm. - Located within the safety cage, forward of the centre line of the rear wheels, no more than 65cm from the vertical plane through the longitudinal axis of the car - Floor pan cut above the original fuel cell compartment exclusive for the installation of the supplementary fuel cell volume in the cockpit is permitted. Structural panels cannot be cut or modified. - The upper (internal) housing may be of mild steel or aluminium both 1.5mm minimum nominal thickness bolted or welded to the body shell or be crushable structure with similar properties as the lower housing. - An add-on fuel cell (FT3 1999, FT3.5 or FT5) on the top of the main fuel cell and installed in a housing corresponding to this regulation may be used up to the total maximal fuel volume. (Certification) - External refuelling can be used (Art. 253). (Certification). - For fuel tanks with one filler neck FIA homologated non-return valve is mandatory (App. J. Art. 253.14). (Certification) - In-board fuel tank filler must be protected by a fireproof and liquid-proof fire-wall. (Certification) <p>a) FIA Safety Fuel Cells will satisfy the following conditions (Certification):</p> <ul style="list-style-type: none"> - Fuel cell cover's lowest surface should have similar area and position in the car as the production fuel cell. (WSC approval) - The rest of the fuel cell including its cover has to be higher than 40mm in respect to production fuel cell's lowest surface. - Simple tunnel (no closed opening through fuel cell) for exhaust tube is allowed. - Fuel cell housing fixation to the body shell will be made using at least 6 (six) fixing points with M8 grade 8.8 bolts installed according to the FIA Drawing 253-65. WSC approved fixing systems with equivalent solidity may be used. (Certification) - An add-on fuel cell (FT3 1999, FT3.5 or FT5) on the top of the main fuel cell and installed in a housing corresponding to this regulation may be used up to the total maximal fuel volume. (Certification) <p>b) It is also possible to use a catalogue rectangular shaped FIA Safety Fuel Cell coming from an FIA-approved manufacturer (FIA FT3 1999 minimum specifications). (Certification). The Fuel Cell must be fitted as follows:</p> <ul style="list-style-type: none"> - located within the safety cage - forward of the centre line of the rear wheels - behind the vertical plane tangent to the most rear point of the driver's seat back - no more than 65cm from the vertical plane through the longitudinal axis of the car - The fuel tank must be contained in a close-fitting flameproof and liquid-proof lower (external) housing that has no other mechanical function including a crushable structure on all surfaces except the one in contact with the body shell. - The crushable structure must be a honeycomb sandwich construction based on a fire-resistant core of a minimum crushing strength of 18N/cm². The sandwich construction must include two skins of 1.5 mm thickness having a tensile strength of minimum 225N/mm² and must have minimum thickness of 10 mm. - Cut-out of the floor plan is permitted. - Lower surface of the tank housing at least 100mm above road (measured by ride height of 80mm). - mild steel or aluminium 1.5mm minimum nominal thickness fuel cell cover bolted or welded to the body shell (fire wall) (Certification) - An add-on fuel cell (FT3 1999, FT3.5 or FT5) on the top of the main fuel cell and installed in a housing corresponding to this regulation may be used up to the total maximal fuel volume. (Certification) - In case of bolting (fuel cell housing or cover) minimum M6 8.8 bolts spaced at max. 200mm must be used. Different designs have to be WSC approved before implementation.

7.2	<p>Fuel circuit</p> <p><u>Fuel lines:</u> Mass Production Fuel Lines may be used outside the cockpit. The protection will correspond to FIA Appendix J, Art. 253.3.1. Other fuel lines must correspond to the prescriptions of Article 253-3 of FIA Appendix J. The installation is free provided that the prescriptions of Article 253-3 of FIA Appendix J are respected</p> <p><u>Fuel sampling connector</u> The car must be fitted inside the engine compartment with a FIA approved self-sealing connector for fuel sampling (Technical list n°5) on the fuel feed line directly before the fuel high pressure pump. The competitors will provide to the Technical Delegate on his request a connection hose to this connector.</p>
7.3	<p>Electric Fuel Pumps (Certification)</p> <p>All Electric Fuel Pumps must stop by stalling engine.</p>
ART. 8	ELECTRICAL EQUIPMENT
8.1	<p>Windscreen wiper</p> <p>Any mass production wiper motor system may be used with original number of working wiper blades (Certification)</p> <p>The windscreen washer tank may be modified (free position) or removed.</p> <p>Complete rear window wiper and washer system may be removed. (Certification)</p>
8.2	<p>Engine Starter</p> <p>The production starter must be fitted and must be in working order at all times of the competition. The driver must be able to operate the starter when seated normally. Manufacturers may apply for alternative OEM Starter. (Certification)</p>
8.3	<p>Lighting equipment</p>
8.3.1	<p>The exterior lighting equipment must at least ensure the following functions: headlights, front and rear direction indicators, stop lights, rain light (see 8.3.2) and rear tail lights and must be in working order at all times of the competition.</p> <p>The exterior surface and appearance of the mass production lights cannot be modified but the interior elements may be removed. (Certification). Exception for the fender indicators which are free.</p> <p>Cars must be prepared to activate at promoter decision Low Beam Lights Flashing at 2Hz - 4Hz at any speed limiter mode.</p>
8.3.2	<p>Front Headlights – VO</p> <p>It is possible to certify as VO, new front head lights with the following characteristics:</p> <ul style="list-style-type: none"> - external cover transparent and with the same shape as the production parts. - light minimum power 60 W. LED admitted with minimum total surface of 50 cm². - Minimum weight: 3 kg each. - casing: plastic material with same fixing point as the production parts.
8.3.3	<p>Rain lights: Rain Light is compulsory. (Certification)</p> <p>For TCR Car certified after 01.01.2025, only FIA approved rain light units (Technical List n° 76) located in the tail gate, boot lid or replacing the 3rd brake light placed on the car's centre line may be used.</p>
8.4	<p>Starter Battery</p> <p>Only 1 (one) dry starter battery defined with the following specifications may be fit in a car is allowed. Minimum weight: 3kg Type: certified (Li-Ion may be accepted, while other exotic types will not be accepted). Capacity: free (certified) Make: free as far as the certified capacity, location, protection and fixation are used. Location: In the production location, boot or in the cockpit. If in the cockpit, it must be situated behind a vertical and transversal tangent plane to the rearmost point of driver's seat or in the rear passengers' foot well. (Certification) Fixation and protection: Should the battery be moved from its production position App. J, Art.255.5.8.3 applies. Insulating cover: The terminals must be electrically protected with an insulating cover. It must be possible at all times to start the engine with the energy of the battery transported on board fit on the vehicle. It is possible to certify (in compliance with this article, and art. 14.12 – Battery Fuse) an alternative battery with a VO, without changing the certified position.</p>
8.5	<p>Electric loom (engine, car & data logger)</p> <p>Production or racing loom (Certification).</p>

8.6

Belt drive, alternator

The belt drive may be modified by removing not used belt driven aggregates and by repositioning the alternator. (Certification).

The alternator may be replaced with another mass production one. The alternator pulley, belt and the bracket are free. (Certification).

The alternator must be operational at any time.

ART. 9

TRANSMISSION

9.1

Transmission system

For cars fitted with a paddle shift and/or a power driven clutch with electronic or pneumatic control, the Technical Delegate may at any time oblige the competitor to use in competition the reference unit(s) registered with the WSC by the Manufacturer.

9.2- 9.1

Clutch

The clutch has to be the mass production one or certified under following conditions:

- Racing Catalogue pressed-type multi-discs sinter-cermetalic; cushion clutches are not allowed.
- Minimum Discs Dia. 183mm (7¼")
- Clutch Control System hydraulic or mechanic actuated by the driver's foot
- Clutch release bearing is free (catalogue parts).

9.3 9.2

Gearbox

Mass production gearbox coming from the production model or from another car of the same group may be used (Certification). In the latter case a gear box adapter to the engine and gearbox brackets may be used. (Certification)

The mass production gearbox will be certified and used under following conditions:

- Mass production ratios
- 1 (one) reverse gear, selectable at any moment by the driver while the engine is running and the car is stopped
- Every gear must be able to be engaged and in working order.
- Gear changes must be made mechanically or using Paddle Shift (after-market or catalogue part).
- Interference to Engine Control for shifting allowed (Ignition cut or power reduction)
- Each individual gear change must be separately and solely initiated and commanded by the driver.

The use of paddle shift on mass production gearbox using catalogue (after-market) parts may has to be certified. The gear box control unit will be sealed and may be at any time be replaced by the technical delegate with the reference part. It is not allowed to alter the certified operating data. Manufacturers will provide to the technical delegate free of charge for the duration of participation of their cars to the FIA TCR world Tour, Transmission Electronic Control Unit(s) (ECU).

Competitors shall provide any data requested by the technical delegate, about the gearbox control unit.

One catalogue racing sequential gearbox with one set of ratios may be certified under following conditions:

- A maximum of 6 (six) forward gears
- 1 (one) reverse gear, selectable at any moment by the driver while the engine is running and the car is stopped
- Every gear must be able to be engaged and in working order.
- Gear changes must be made mechanically or using Paddle Shift (catalogue part).
- Interference to Engine Control for shifting allowed (Ignition cut or power reduction)
- Each individual gear change must be separately and solely initiated and commanded by the driver.
- Any system that permits more than one gear pair to be engaged to the drive train at any time is prohibited.
- Instantaneous gearshifts are forbidden.
- Gearshifts have to be distinct sequential actions where the extraction of the current dog gear is subsequently followed by the insertion of the target dog gear.
- The dog gear is considered extracted when its position is not able to transmit any torque.
- Catalogue limited slip differential

A 2nd catalogue racing sequential gearbox can be certified at any time as option VO using similar technical parameters:

- Interchangeability (same clutch, starter, etc.)
- Similar lubrication principle
- Total ratios in each gear (deviation ±3%)
- Weight (deviation limit: maximum 2 kg lighter)
- Catalogue limited slip differential

Car models using mass production gearbox and/or sequential gearbox(es) will certify only 1 (one) GBX type per car (Chassis no.) and are not allowed to change back and forth between different certified variants.

A new gearbox cooling using catalogue parts (pump, filter, cooler, lines, thermostat, etc.) may be certified. Mass Production Gearbox Cooling may be used without modification. Modified mass production gearbox cooling must be also certified.

An additional mass production gearbox oil cooler may be certified with a VO (Variant Option), without any modification to the bodywork.

9.4-9.3

Final Drive

The final drive may be production or new (Certification).

For each certified gear box one new final drive ratio or one new final drive ratio pair (for transmission using two final gear pairs for gearboxes with 2 lay shafts) in the certified housing may be certified.

~~Final drive cooling using catalogue parts (pump, filter, cooler, lines, thermostat, etc.) may be certified.~~

9.5-9.4

Limited Slip Differential

Any mass production limited slip differential may be used in mass production gearbox with production parameters but the settings cannot be modified during driving. (Certification)

The mass production differential fitted in the mass production gearbox may be replaced by a catalogue mechanical limited slip differential inside the drive unit housing (Certification).

~~Only the WSC differentials may be chosen as VO solution, as described the "TCR Notification_WSC Slip Limited Differential VO" document.~~

It is permitted to remove material from the inside of the production housing. It must at all times be possible to clearly recognize the housing as the certified standard housing. (Certification)

Only one (1) catalogue mechanical limited slip differential may be offered for each racing sequential gearbox. (Certification).

For each mechanical limited slip differentials 4 (four) pairs of pressure angles machined on one or several pressure rings pairs may be certified. Control jigs for the pressure angles will be made available on WSC request.

The use of metallic friction plates & disks is mandatory (no carbon friction plates / disks or CFRP plated parts allowed).

9.6-9.5

Drive shafts

For each certified gear box different drive shafts may be certified. Principle of the joint on the wheel side joint must be original.

Drive shaft's length is free.

ART. 10

AXLES, SUSPENSION AND STEERING

10.1

Generals

Wheelbase: Nominal wheelbase of the race car must not exceed the nominal wheelbase of the original car + 60 mm with the following constraints:

- The wheels can only be moved towards their end (i.e., front wheels towards the front) by 30 mm maximum.
- This measurement must be taken from a datum-point on the body shell. (Certification)
- Tolerance on race car wheelbase ± 10 mm.

Front and Rear overhangs

- Front: Defined by front bumper & Front splitter position (the most forward of the two).
- Rear: Defined by rear bumper position or rear wing position (the most backward of the two).

No modifications of the chassis for new suspension pick up points

- The position of the new pick-up points is free; max ± 20 mm adjustment in all directions (Certification)
- Bolted brackets for suspension elements are free (Certification)

Position of the front and rear overhangs correspond to the production car. (Certification)

10.2

Wheel Hubs and Bearings

The wheel hubs may be re-machined using similar wheel fixation (number of fixation points, same bolt PCD and thread), to allow the use of a stronger mass production wheel bearing. Mass production wheel hubs may be used. The rim centring on the hub may be modified. (Certification)

10.3

Bearings, Silent blocks, Rubber bearing

Production bearing on suspension arms may be replaced by uniballs or bush bearings (Certification). No rolling contact bearings accepted.

Any elastokinematic elements (rubber, metallic spring, etc.) allowing defined modification of suspension parameters (toe, camber, etc.) under lateral or longitudinal forces are forbidden.

10.4

Front wishbones/upright/struts

The working principle and the number of pivot points on the wishbones/upright/struts and on the chassis/subframe have to be maintained. The parts are free. (Certification)

Local modifications of the chassis and pick-up points may be accepted: the manufacturer must present to WSC (for approval) the concept before the final certification, at the design stage: no parts will be accepted without previous authorization from the Technical Department of WSC

Double-wishbone axle may be changed to triangular control arm axle. (Certification)

- 10.5 Rear suspension**
- Production suspension parts may be reinforced or modified. Suspension arms may be replaced by new parts (Certification)
- Twist beam may be changed into double trailing arm, keeping the same external pivot points and adding two additional points on chassis. (Certification)
- 10.6 Anti-roll bars**
- Anti-roll bars made from ferrous material, their bearings and their actuation are free. Adjustable lever arms (no turning blades) may be used without adjustment from the cockpit. (Certification, maximum 3 sets for front and rear axle)
- If the production axle is not fitting anti-roll bar, it may be added. (Certification)
- The anti-roll bars may be disconnected but must remain in the car.
- 10.7 Suspension Springs**
- The suspension of each wheel may have a maximum of two cylindrical steel springs mounted in series, with linear characteristics each.
- ~~The two springs must be separated from each other only through a specific spring seat for fixing and diameter adaptation. The spring seats are free. (Certification)~~
- The spring "helper" (that sits above or below the main spring) must be certified.
 - Has to be a mass production part, from a commercial catalogue with declared part number and max stiffness of 10 N/mm.
 - The two springs (main + helper) must be separated from each other only through a specific adapter (to be certified) made in one single piece.
- Rubber bump stops and packers are free.
- Only polymeric rebound and bump stops are allowed, rebound springs are forbidden.
- Packers are non-elastic elements used to change the contact point of the rebound and bump stops.
- 10.8 Minimum Ride height**
- The minimum ride height has to be respected at any time during the event.
- For the checking of the minimum ride height, the pressure of the tyres must not be less than 1.5bars.
- Reference Minimum Ride Height, refer to the latest technical bulletins.
- 10.9 Shock absorbers**
- Only commercial hydraulic 2-way adjustable shock absorbers (one per wheel) fitted in the same location and similar position like in the basic mass production car are allowed. (Certification)
- All original internal parts offered by the manufacturer of the certified shock absorber in its commercial catalogues and free available on the market are allowed.
- Only oil (grease is not allowed) can be used as damping liquid in the dampers.
- The use of following technical solutions is forbidden:
- Rolling contact bearings
 - Inertial shock absorbers (J-Damper)
 - Floating-piston for amplitude/frequency depending damping
 - Hydraulic bump-stops
 - Connection between shock absorbers (hydraulic, electric, electronic or mechanic, other than antiroll bars)
 - Set-up modification from cockpit
 - Set-up modification by moving car by computer control (active damping)
 - Motion sensing valves (G-valves)
 - Electro valves
 - Solid-materially additives to the damper-oil
- Manufacturers may apply for different shock absorber brands and /or commercial designations at any time (VO Certification)
- 10.10 Steering**
- The steering lock must be dismounted and the column adjusting system must be locked with tools. Steering column brackets may be replaced. The new brackets may be connected to the chassis or to the safety cage (Certification).
- The steering wheel must be certified.
- The fitting of displays, switches and control lights on the steering wheel is allowed if offered by the steering wheel supplier. (Certification)
- It is possible to certificate a new steering rack. ~~even swapping from electric to hydraulic assistance (and vice-versa). New steering rack can be made assembling OEM mass production components, with minimal modification for race usage and part matching (WSC approval before certification).~~ All components of the new one must be of OEM mass production origin with minimal modifications for race usage and parts matching. (Origin has to be proved). Chassis firewall could be locally modified to adapt new routing for steering column. Steering column could be modified to be adapted to new steering rack ~~matching spline~~. (Certification)

10.11	<p>The steering wheel must be fitted with a quick release system. (Certification)</p> <p>Power steering</p> <p>For cars fitted with an automatically variable power steering the Technical Delegate may at any time oblige the competitor to use the reference unit WSC registered by the Manufacturer.</p> <p>Electric servo-motor has to be OEM components without any modification, management software has to be certified. Control unit has to be linked directly to the servo-motor and without any car VCU and ECU connections. Hydraulic pump has to be an OEM component without any modification (certification).</p> <p>In case of using different steering rack the correspondent assistance principle can be used with parts of OEM mass production origin. (Certification)</p>
ART.11	BRAKES
11.1	<p>Generals</p> <p>Master cylinder(s) dimensions are free; The type and make will be certified. Max brake diameter 382mm (width free); certified brand, diameter and bells Steel brake discs (no ceramic coating allowed) Max 6 pistons front calliper (one calliper / wheel, Certification) Max 2 pistons rear calliper (one calliper / wheel, Certification) Brake pads are free (2 pads / calliper) The brake callipers must be made from aluminium materials with a modulus of elasticity no greater than 80Gpa. (Certification) Simple brake effort repartition system(s) (hydraulic or/and mechanic) is (are) allowed. (Certification)</p>
11.2	<p>Brake fluid tanks</p> <p>The brake and clutch fluid tanks will be fixed in the engine bay. The brake fluid hoses may pass through the cockpit. (Certification)</p>
11.3	<p>Brake cooling</p> <p>Ducts may be metallic (steel or aluminium sheet), flexible hoses or be made in composite material. (Certification) Openings to bring the cooling air to the brakes must be certified. Cooling air ducts on the brake discs cannot be bigger than the external diameter of the brake discs itself Ducts may wrap the calliper up to a maximum of 20mm around it.</p> <p>Tape on the external air inlets to control regulate the brake temperature is allowed.</p>
11.4	<p>Parking brake</p> <p>The parking brake working on the brake system (not on the transmission) is mandatory and must be operative at any time.</p> <p>The production parking brake may be removed or replaced by a hydraulic valve or master cylinder operated manually by the driver without any intermediate system. (Certification)</p>
ART. 12	WHEELS AND TYRES
12.1	<p>Generals</p> <p>Any system allowing the car to be driven without pressure in the tyres is forbidden. Pressure and temperature sensors are forbidden.</p>
12.2	<p>Dimensions</p> <p>Wheels: (Certification)</p> <ul style="list-style-type: none"> - Dimensions of the 4 wheels: identical - Rim's maximum dimensions: 10"x18" (width x diameter) - Complete wheel: Maximum width at 2bars: 280mm - The diameters at inner and outer rim edges must be identical with a tolerance of ±2.0mm. - Rim's minimum weight: 11kg - Rim's material: Cast aluminium alloy - Rim's Construction: Single unit - Metal inserts are allowed for the passage of the drive to the wheel. - Air extractors are forbidden. - Max OD diameter = 675 mm @ 2 bar <p>Manufacturers may apply for different interchangeable wheels at any time (VO Certification)</p>
12.3	<p>Wheel visibility</p> <p>The upper part of the complete wheel (flange + rim + tire) in straight ahead position and above the wheel's centre must be vertically covered by the bodywork.</p>

12.4	<p>Wheel attachment</p> <p>Wheel fixations by bolts may be changed to stud fixations respectively knurled-head screws and steel nuts, provided that the number of fixation points, as mentioned above, remains unchanged. (Certification)</p> <p>Certified wheel spacers are allowed.</p>
12.5	<p>Pressure control valves</p> <p>Pressure control valves on the wheels are forbidden.</p>
ART. 13	COCKPIT
13.1	<p>Equipment permitted in the cockpit</p> <p>The only components which can be added in the cockpit are:</p> <ul style="list-style-type: none"> - Safety equipment and structures - Seat, instruments and any other controls necessary for driving including the brake balance adjuster - Electronic and electrical equipment; it is permitted to channel air towards the electronic equipment on condition that the ventilation devices comply with the present regulations. - team communication radio - Driver cooling and ventilation equipment - Ballasts - Braking and clutch system hydraulic lines with properly secured connectors - Pneumatic jacks and their pipes - Battery - Fuel, hydraulic lines with properly secured connectors (App. J. Art. 253.3.2) <p>None of the above items may hinder cockpit exit, the hatch functionality or the driver's visibility.</p> <p>The above components must be covered where necessary by a rigid protective material to minimise injury, and their mountings must be able to withstand 25g deceleration.</p> <p>One air duct for driver's cooling from one of the engine cooling air boxes through the bulkhead max dia. 51mm in fire wall quality is allowed. (Certification)</p>
22 13.2	<p>Cockpit exit time</p> <p>The driver, seated in his normal driving position, must be able to get out from the cockpit in 7 seconds through the driver's door and in 9 seconds through the passenger's door.</p> <p>For the purposes of these tests, the driver must be wearing all normal driving equipment, the seat belts must be fastened, the steering wheel must be in place, and the doors must be closed.</p>
13.3	N/A
ART. 14	SAFETY EQUIPMENT
14.1	<p>Fire extinguishers</p> <p>All cars must be equipped with an extinguishing system homologated by the FIA in accordance with Article 253.7.2. (FIA Technical List nos. 16 and 52). The Technical List no. 52 (FIA Standard 8865-2015) is mandatory for cars certified from 2020 on. (Certification)</p>
14.2	<p>Safety belts</p> <p>The safety belts must comply with FIA Standard N°8853/2016 (FIA Technical List no. 57) and have to use the certified fixing points. .</p>
14.3	<p>Rear view mirrors</p> <p>The car must be fitted with 2 (two) production external rear view mirrors.</p> <p>The use of one internal rear-view mirror is permitted.</p>
14.4	<p>Driver Seat</p> <p>The driver's seat must be FIA homologated and not modified:</p> <ul style="list-style-type: none"> - FIA Standard 8855-1999 (FIA Technical List 12) using exclusively WSC certificated seat brackets. (Certification) Several homologated sizes of the certified seat model may be used with certificated seat brackets (Certification) - FIA Standard 8862-2009 (FIA Technical List 40) and related homologated brackets. - FIA Standards 8855-2021 (FIA Technical List 91) and related homologated brackets – minimum level of specification required, for car certified after 01/01/2026. - <p>Dimensions of cushions and foam inserts used between driver and seats must comply with App. J, Art. 253.16.</p>

If the original seat attachment points on the body shell are changed, the new attachment points for seat or seat supports must comply with the provisions of App. J, Art. 253.16. (Certification)

The seat must be mounted by means of at least four (4) M8 bolts of at least 10.9 quality.

Seat position

- Transversally: Seat centreline must not be less than 270mm from the car's centreline.
- Longitudinally limit: No part of the seat may be situated beyond the vertical and transverse plane defined by the front edge of the original back seat. The most rear seat position will be documented in the Technical Form related to the chassis. (Certification)

14.5 General Circuit Breaker

The driver, when seated normally at the steering wheel with the safety belts fastened, must be able to cut off all the electrical circuits and switch off the engine by means of a spark-proof breaker switch.

The switch must be positioned on the dashboard or in any other place easily accessible and must be able to be handled from inside the car by the driver seated and secured by his safety belts.

An exterior General Circuit Breaker must be installed and clearly identified by a symbol showing a red spark in a white-edged blue triangle in conformity with FIA App. J, Art 253.13.

- Recommended location: at the lower part of the driver's side windscreen pillar.
- Location following FIA Art 253.13 will be also accepted.

14.6 Protection Nets

A protective window net is compulsory. (Certification)

It must meet the following specifications:

- the net must be made up of woven strips at least 19mm (3/4") wide;
- the meshes must be a minimum of 25 x 25mm and a maximum of 60 x 60mm. The woven strips must be non-flammable and sewn together at each point of crossing. The net must not be of a temporary nature.
- viewed from the side, it must reach from the centre of the steering wheel to the B-pillar.

Fixation:

The net must be attached either to the safety cage or to the chassis, above the driver's window, by means of a rapid release system that will function even if the car turns over.

The net must open from the top downwards when car is on wheels.

The use of "Velcro" lock is not permitted.

It must be possible to detach the net with one hand. To this end, the handle or lever must have coloured markings ("dayglo" orange).

A push-button release system is authorised provided that it respects the prescriptions of this article.

The push-buttons must be visible from the outside, be of a contrasting colour and be marked "press".

Racing nets according to FIA 8863-2013 standard (Technical list n°48) may be certified as VO. Fixation: Racing nets (FIA homologated) must be attached to the certified mounting points following FIA specifications.

14.6.1 Racing Nets

For TCR Cars certified after 01.01.2025, the racing nets (Technical List N°48) are mandatory and must be attached according to the racing nets installation specification for touring and grand touring cars.

14.7 Towing devices

All cars will be equipped with certified rear and front towing devices. It will be clearly visible and coloured in yellow, red or orange.

The towing devices must be within the perimeter of the bodywork as viewed from above.

It must allow the passage of a cylinder with a diameter of 60mm.

It must allow moving the car with blocked wheels using the cars braking system on a dry surface (concrete or asphalt) by applying traction on a plane parallel to the ground, with an angle of $\pm 15^\circ$ to the longitudinal centreline of the car.

The car must be fitted with the control dry weather tyres.

Flexible towing devices must be always in good condition without abrasions or kinks.

14.8 Fuel system

Fuel lines

Flexibles lines inside the cockpit must be in compliance with of aviation quality (App. J, Art. 253.3.2).

The installation is free design provided that the prescriptions of App. J, Art. 253.3 are respected.

Manufacturers may apply for alternative fuel cell ventilation valve with similar connections. (Certification)

14.9 Hydraulic pressure lines

App. J, Art. 253.3.2 applies.

14.10 Side Protection Panel

A side protection panel, made of composite material, fixed to the body shell or the safety cage may be optionally used. (Certification).

14.11 FIA Car Lifting Device

	Manufacturers may apply for options (VO). (Certification)
14.12	<p>Battery fuse</p> <p>Battery protection against accidental short-circuiting between the battery plus pole or the power supply cable and ground (vehicle body) fitted closest possible to the battery on the ground cable or on both battery cables is mandatory. (Certification after testing according to WSC test method)</p> <ul style="list-style-type: none"> - Reaction time in the TCR car: less than 3 sec.
14.13	<p>Medical Lights</p> <p>Cars using TCR Engine ECU will be prepared to activate Medical Lights at promoter's decision. Manufacturers may apply for VO certification.</p>
14.14	<p>Driving Systems for drivers with disabilities</p> <p>Only systems certified by a TCR manufacturer are authorized to be used. The system must be certified against a specific vehicle (specific chassis number).</p>
ART. 15	<p>SAFETY STRUCTURES</p> <p>Safety cage</p> <p>The safety cage must be homologated or certified by FIA or an FIA recognised ASN (App. J, Art. 253.8.1.b). For Static Load Tests or for Arithmetical Proofs the weight of the car will be the Target Racing Weight.</p> <p>Regarding The protective paddings on safety cage tubes which may come in contact with the driver have to comply with Art. 253.8.4 of the App. J applies.</p>
ART. 16	<p>FUEL</p> <p>16.1 Fuel specification</p> <p>Fuel specification must be approved by FIA/WSC.</p> <p>The organiser will specify the fuel provider(s). The fuels correspond to FIA App. J, Art. 252.9 in guaranteed Super Plus Quality (98 RON, 88 MON) with maximum 10% ethanol content (EN228).</p> <p>Recommendation of use for "sustainable fuel" proposed by the promoter must be submitted to FIA / WSC for evaluation before use.</p> <p>The fuel must comply with the official samples at any time of the competition. Additives of any kind are forbidden.</p> <p>The fuel temperature may not be more than 20°C lower than the ambient temperature.</p> <p>16.2 Air</p> <p>Only air may be mixed with the fuel as an oxidant.</p>
ART. 17	<p>FINAL TEXT</p> <p>The binding text of these regulations is the English version.</p>
ART. 18	<p>APPENDIXES TO THIS TECHNICAL REGULATION</p> <p>The TCR Technical Bulletin are published (in progressive number) on the on-going year/season and are published on the TCR-Hub area. The existing list of TCR Technical Notifications Appendixes (published on the TCR Hub area) documents at the beginning of this year are:</p> <p>The list of Appendixes published at the end of this document are:</p> <ul style="list-style-type: none"> - APPENDIX A: TCR - Gen I cars <p>TCR Notification Boost Monitoring Method TCR Notification_CWFormula TCR Notification_DrivingSystemsDriverswithdisabilities TCR Notification_TCR Cars Max Weight TCR Notification_WSC Slip Limited Differential VO TCR Notification TCR Gen I</p>

TCR Notification_Technical Forms
 The existing list of TCR Certification Documents Appendixes documents (published on the TCR Server, in the manufacturer area) at the beginning of this year are:
 TCR Certification_Air Inlet Pressure Sensor Manual
 TCR Certification_Air Inlet Temperature Sensor Manual
 TCR Certification_Battery Fuse Test Method
 TCR Certification_BoP-WT Test Information
 TCR Certification_Engine Dyno Test Guidelines
 TCR Certification_EVO
 TCR Certification_Inspection Information
 TCR Certification_Overhang
 TCR Certification_TCR ECU Installation Manual
 TCR Certification_TCR Turbo List
 TCR Certification_BoP CoG Test Information
 TCR Certification_Fuel

APPENDIX A: TCR - Gen I Cars

Any TCR Cars racing in TCR Gen I competitions is subject to the following general rules:

- a) TCR Gen I cars are the one listed in the following list.
 WSC has the rights to establish which car models shall be present in the list.
 WSC is the only entity holding the rights to manage the respective Balance of Performance (BoP) table and reserves the right to adjust it during the racing season via TCR Technical Bulletin "TCR Gen I".

MANUFACTURER	MODEL	TF #	TF Extensions	Engine Map [#]	Target Racing Weight [kg]	Ballast [kg]	Minimum Racing Weight [kg]	Minimum Ride Height [mm]
Alfa Romeo	Giulietta RF TCR	TF-022	VO23, ER30, ER60, VF32, VO31, VO59, ER88	M6	1265	-10	1255	70
Audi	RS3 LMS DSG	TF-009	VO18, VO25/29, VO45, VO63, VO109, VO156, VO164, VF375, ER46, ER61, ER62, ER110, ER141, ER165, ER189, ER329, AD150, AD176, AD337, AD394	R6	1230	+20	1250	70
Audi	RS3 LMS SEQ	TF-010	VO18, VO25/29, VO45, VO72, VO107, VO157, VO166, VF376, ER46, ER64, ER71, ER108, ER142, ER167, ER190, ER328, AD151, AD177, AD338, AD393	R5	1265	-10	1255	70
Cupra	Cupra TCR DSG	TF-043	ER65, ER66, VO44	R6	1230	0	1230	70
Cupra	Cupra TCR SEQ	TF-035	ER73, ER74, VO44	R5	1265	0	1265	70
Honda	Civic FK2 TCR	TF-011	VO20, VF83, ER67, ER86, VO90	M5	1265	-20	1245	70
Lada	Vesta TCR	TF-038	-	M5	1265	+10	1275	70
Opel/Holden/Vauxhall	Astra TCR	TF-005	VO77	M6	1265	0	1265	70
Peugeot	308 Racing Cup	TF-008	VO78	M6	1225	-30	1195	60
Seat	Leon Cup Racer	TF-017	-	M5	1265	0	1265	70
Subaru	WRX STI TCR	TF-007	VO84	M6	1265	-10	1255	70
Volkswagen	Golf GTI TCR DSG	TF-012	VO19, ER36/45, VO41/46, VF42/47, EV48, ER79, VO80, C193	R6	1230	-10	1220	60
Volkswagen	Golf GTI TCR SEQ	TF-014	VO19, ER36/45, VO41/46, VF42/47, EV40, ER81, VO82, C194	R5	1265	-10	1255	60

- b) Any TCR Gen I car must be in compliance to the TCR Technical Form and the Extensions presented by the competitor, in respect of the restriction(s) reported in this document and in respect of the table above.
 For any TCR Gen I car models interested, any safety related ER document about the Fuel tank and the Battery Fuse may be used (despite its certification date). These documents (TF in original copy or QR code, Extensions in printed copy) must be presented by the Competitor to the Technical Delegate at each Competition in which the car takes part.
- c) A TCR Gen I car may be equipped with some components that can differ from the TCR Technical Form. This is applicable only if all the conditions listed below are verified:
- o This applies only to:
 - driver seat
 - seat brackets

- fuel tank (up to FIA spec.)
- fire extinguisher systems.
- The certified component documented in the original TCR Technical Form is no more present in the latest version of the Technical List of FIA of reference.
- The new component fit in the car is officially present in the latest version of the Technical List of FIA of reference.

A *TCR Gen I car* may be equipped with a fully functional Evo5 Data logger system (including wiring loom updates), in replacement of the certified Evo4 data logger system.