

ARTICLE 275A
2026 FORMULA REGIONAL - 2ND GEN TECHNICAL REGULATIONS

Colour Code:

Changes for Issue 6.0 (vs 4.2)

SUMMARY

ARTICLE 1 : DEFINITIONS

- 1.1 Formula Regional car
- 1.2 Automobile
- 1.3 Land vehicle
- 1.4 Bodywork
- 1.5 Wheel
- 1.6 Complete wheel
- 1.7 Automobile make
- 1.8 Event
- 1.9 Weight
- 1.10 Engine cubic capacity
- 1.11 Pressure charging
- 1.12 Intake system
- 1.13 Main structure
- 1.14 Sprung suspension
- 1.15 Active suspension
- 1.16 Cockpit
- 1.17 Survival cell
- 1.18 Composite structure
- 1.19 Telemetry
- 1.20 Semi-automatic gearbox
- 1.21 Cockpit padding
- 1.22 Electronically controlled
- 1.23 Open and closed sections
- 1.24 Engine
- 1.25 Power Unit
- 1.26 Energy Recovery System (ERS)
- 1.27 Motor Generator Unit (MGU)
- 1.28 Energy Store (ES)
- 1.29 DC-DC Converter
- 1.30 Auxiliary circuit
- 1.31 Power circuit
- 1.32 Maximum working voltage
- 1.33 Battery management system (BMS)
- 1.34 ES cells

ARTICLE 2 : REGULATIONS

- 2.1 Role of the FIA
- 2.2 Publication date for amendments
- 2.3 Permanent compliance with the regulations

- 2.4 Measurements
- 2.5 Technical passport
- 2.6 Eligible cars
- 2.7 Changes to car design

ARTICLE 3 : BODYWORK AND DIMENSIONS

- 3.1 Definitions
- 3.2 Overall dimensions
- 3.3 Front Wing
- 3.4 Front Bodywork
- 3.5 Rear Bodywork
- 3.6 Rear Wing
- 3.7 Floor and Diffuser
- 3.8 Roll Structure Fairing
- 3.9 Wheel Bodywork
- 3.10 Aerodynamic influence
- 3.11 Bodywork flexibility

ARTICLE 4 : WEIGHT

- 4.1 Minimum weight
- 4.2 Ballast
- 4.3 Adding during the race

ARTICLE 5 : POWER UNIT

- 5.1 Power Unit homologation
- 5.2 General Power Unit specification
- 5.3 Main Power Unit and intake system dimensions
- 5.4 Power Unit maximum weight
- 5.5 Power Unit Control Unit
- 5.6 General electrical safety
- 5.7 Power Circuit
- 5.8 Energy Store (ES)
- 5.9 Motor Generator Unit (MGU)
- 5.10 Push to Pass System

ARTICLE 6 : PIPING AND FUEL TANKS

- 6.1 Fuel tanks
- 6.2 Fittings and piping
- 6.3 Crushable structure
- 6.4 Tank fillers
- 6.5 Refuelling

ARTICLE 7 : OIL AND COOLING SYSTEMS

- 7.1 Location of oil tanks
- 7.2 Longitudinal location of oil system
- 7.3 Catch tank
- 7.4 Transversal location of oil system
- 7.5 Oil replenishment
- 7.6 Cooling fluids

ARTICLE 8 : ELECTRICAL SYSTEMS

- 8.1 Starter
- 8.2 Starting the engine
- 8.3 Auxiliary battery
- 8.4 Energy Store (ES) position

- 8.5 Accident data recorders
- 8.6 Data logger, sensors, dashboard and/or steering wheel display
- 8.7 Electrical system connection interfaces
- 8.8 Throttle fail safe
- 8.9 Marshalling System / FCY / VSC Interface

ARTICLE 9 : TRANSMISSION TO THE WHEELS

- 9.1 Gearbox Homologation
- 9.2 Four wheel drive
- 9.3 Type of gearbox
- 9.4 Reverse gear
- 9.5 Traction control
- 9.6 Driveshafts
- 9.7 Semi-automatic gear change system
- 9.8 Clutch disengagement

ARTICLE 10 : SUSPENSION AND STEERING

- 10.1 General
- 10.2 Active suspension
- 10.3 Chromium plating
- 10.4 Suspension members
- 10.5 Suspension dampers
- 10.6 Sprung suspension
- 10.7 Springs
- 10.8 Suspension uprights
- 10.9 Wheel bearings
- 10.10 Steering

ARTICLE 11 : BRAKES

- 11.1 Separate circuits
- 11.2 Brake discs
- 11.3 Brake calipers
- 11.4 Liquid cooling
- 11.5 Brake pressure modulation
- 11.6 Brake pads

ARTICLE 12 : WHEELS AND TYRES

- 12.1 Location
- 12.2 Wheel material
- 12.3 Dimensions and weights
- 12.4 Maximum number of wheels
- 12.5 Wheel retention
- 12.6 Pressure control valves
- 12.7 Aerodynamic influence

ARTICLE 13 : COCKPIT

- 13.1 Accommodating different driver sizes
- 13.2 Cockpit opening
- 13.3 Steering wheel
- 13.4 Internal cross section
- 13.5 Position of the driver's feet
- 13.6 Clutch, brake and throttle pedal

ARTICLE 14 : SAFETY EQUIPMENT

- 14.1 Fire extinguishers
- 14.2 Master switch
- 14.3 Rear view mirrors
- 14.4 Safety belts
- 14.5 Rear light
- 14.6 Cockpit padding
- 14.7 Seat, seat fixing and removal
- 14.8 Head and neck supports
- 14.9 Towing device

ARTICLE 15 : CAR CONSTRUCTION

- 15.1 Materials used for car construction
- 15.2 Roll structures
- 15.3 Structure behind the driver
- 15.4 Survival cell specifications
- 15.5 Intrusion Protection
- 15.6 Survival cell sidewall requirements
- 15.7 Survival cell safety requirements

ARTICLE 16 : IMPACT TESTING

- 16.1 Conditions applicable to all impact tests
- 16.2 Frontal test 1
- 16.3 Frontal test 2
- 16.4 Rear test
- 16.5 Steering column test

ARTICLE 17 : ROLL STRUCTURE TESTING

- 17.1 Conditions applicable to both roll structure tests
- 17.2 Principal roll structure test
- 17.3 Secondary roll structure test

ARTICLE 18 : STATIC LOAD TESTING

- 18.1 Conditions applicable to all static load tests
- 18.2 Survival cell side strength tests
- 18.3 Survival cell floor test
- 18.4 Cockpit floor test
- 18.5 Cockpit rim test
- 18.6 Suspension pick-up test
- 18.7 Nose push off test
- 18.8 Rear impact structure push off test
- 18.9 Frontal anti-intrusion panel test
- 18.10 Seat bulkhead test

ARTICLE 19 : FUEL

- 19.1 Fuel
- 19.2 Air

ARTICLE 20 : FINAL TEXT

APPENDIX 1 : DRAWINGS

APPENDIX 2 : COMMON CONNECTION INTERFACE

APPENDIX 3 : APPROVAL OF SAFETY STRUCTURES

APPENDIX 4 : REFERENCE SURFACES AND VOLUMES

ARTICLE 1 : DEFINITIONS

1.1 Formula Regional car

Automobile designed solely for speed races on circuits or closed courses.

1.2 Automobile

Land vehicle running on at least four non aligned complete wheels, of which at least two are for steering and at least two for propulsion.

1.3 Land vehicle

A locomotive device propelled by its own means, moving by constantly taking real support on the earth's surface, of which the propulsion and steering are under the control of a driver aboard the vehicle.

1.4 Bodywork

All entirely sprung parts of the car in contact with the external air stream, except cameras, camera housings, rear view mirrors, the secondary roll structure and associated fixings and fairings and the parts definitely associated with the mechanical functioning of the Power Unit, transmission and running gear. Airboxes and radiators are considered to be part of the bodywork.

1.5 Wheel

Flange and rim.

1.6 Complete wheel

Wheel and inflated tyre. The complete wheel is considered part of the suspension system.

1.7 Automobile make

In the case of Formula racing cars, an automobile make is a complete car. When the car manufacturer fits a Power Unit which it does not manufacture, the car shall be considered a hybrid and the name of the Power Unit manufacturer shall be associated with that of the car manufacturer. The name of the car manufacturer must always precede that of the Power Unit manufacturer.

Should a hybrid car win a Championship Title, Cup or Trophy, this will be awarded to the manufacturer of the car.

1.8 Event

An event shall consist of official practice and the race.

1.9 Weight

Is the weight of the car with the driver, wearing his complete racing apparel, at all times during the event.

1.10 Engine cubic capacity

The volume swept in the cylinders of the engine by the movement of the pistons. This volume shall be expressed in cubic centimetres. In calculating engine cubic capacity, the number π shall be 3.1416.

1.11 Pressure charging

Increasing the weight of the charge of the fuel/air mixture in the combustion chamber (over the weight induced by normal atmospheric pressure, ram effect and dynamic effects in the intake and/or exhaust system) by any means whatsoever. The injection of fuel under pressure is not considered to be supercharging.

1.12 Intake system

All the elements between the cylinder head and the external side of the air restrictor.
Main structure

The fully sprung structure of the vehicle to which the suspension and/or spring loads are transmitted, extending longitudinally from the foremost front suspension on the chassis to the rearmost one at the rear.

1.14 Sprung suspension

The means whereby all complete wheels are suspended from the body/chassis unit by a spring medium.

1.15 Active suspension

Any system which allows control of any part of the suspension or of the trim height when the car is moving.

1.16 Cockpit

The volume which accommodates the driver.

1.17 Survival cell

A continuous closed structure containing all fuel tanks and the cockpit.

1.18 Composite structure

Non-homogeneous materials which have a cross-section comprising either two skins bonded to each side of a core material or an assembly of plies which form one laminate.

1.19 Telemetry

The transmission of data between a moving car and anyone connected with the entry of that car.

1.20 Semi-automatic gearbox

One which, when the driver calls for a gear change, takes over the control of one or more of the Power Unit, clutch and gear selectors momentarily to enable the gear to be engaged.

1.21 Cockpit padding

Non-structural parts placed within the cockpit for the sole purpose of improving driver comfort and safety. All such material must be quickly removable without the use of tools.

1.22 Electronically controlled

Any command system or process that utilises semi-conductor or thermionic technology.

1.23 Open and closed sections

A section will be considered closed if it is fully complete within the dimensioned boundary to which it is referenced, if it is not, it will be considered open.

1.24 Engine

The internal combustion engine including ancillaries, sensors, actuators and control systems necessary for its proper function.

1.25 Power Unit

The engine, complete with its ancillaries, the energy recovery system and all sensors, actuators and control systems necessary to make them function at all times.

1.26 Energy Recovery System (ERS)

A system that is designed to recover energy from the car, store that energy and make it available to propel the car and, optionally, to drive any ancillaries and actuation systems necessary for its proper function.

1.27 Motor Generator Unit (MGU)

The Motor Generator Unit is the electrical machine mechanically linked to the powertrain as part of the ERS.

1.28 Energy Store (ES)

The part of ERS that stores electrochemical or mechanical energy, including its safety control electronics and a minimal housing.

1.29 DC-DC Converter

An electronic circuit connected to the Energy Store and whose function is to regulate multi-level voltage outputs for use by the electrical and electronic components of the car and power unit. A DC-DC converter may only consume energy from the energy store and cannot recover energy into the Energy Store. The components directly supplied by the DCDC or indirectly supplied through the non ERS energy storage cannot be used to propel the car or to provide energy to the pressure charging system.

1.30 Auxiliary circuit

The auxiliary circuit includes the ECU, engine actuators, auxiliary battery, alternator (if fitted), fuel pump, rain light, radio, camera, logger, GCU, gearshift compressor and/or gear shift actuators.

1.31 Power circuit

The power circuit consists of all those parts of the electrical equipment that are used for driving the vehicle. It includes the ES, its safety management, the inverter, the MGU, cables and harnesses.

1.32 Maximum working voltage

Highest value of AC voltage (rms) or of DC voltage that can occur under any normal operating conditions according to the manufacturer's specifications, disregarding transients and ripple.

1.33 Battery management system (BMS)

The BMS is a set of important safety systems of the ES. It must detect internal faults and must trigger power reduction delivered from/to the battery or shutdown the ERS if the BMS considers that the ES is operating unsafely.

1.34 ES cells

The elementary part of the ES that produces and stores electricity through electro-chemical reactions.

ARTICLE 2 : REGULATIONS

2.1 Role of the FIA

The following technical regulations for Formula Regional 2nd Gen cars are issued by the FIA.

2.2 Publication date for amendments

Each year in December at the latest, the FIA will publish all changes made to these regulations. All such changes will take effect on the second 1st January following their publication.

Changes made for safety reasons may come into force without notice.

2.3 Permanent compliance with regulations

Automobiles must comply with these regulations in their entirety at all times during an event.

2.4 Measurements

All measurements must be made while the car is stationary on a flat horizontal surface.

2.5 Technical passport and FIA chassis test report

All competitors must be in possession of a technical passport for their car which will be issued by the relevant ASN and must accompany the car at all times.

Furthermore, all competitors must be in possession of an FIA chassis test report for their car which the relevant rolling chassis manufacturer must provide together with each survival cell.

No car will be permitted to take part in an event unless the passport and the FIA chassis test report are available for inspection at initial scrutineering.

2.6 Eligible cars

Only cars homologated as FIA Formula Regional 2nd Gen cars are eligible in an event.

2.7 Changes to car design

2.7.1 General

The complete car is divided into three types of part.

Type 1: These parts must be supplied by the manufacturer and used exactly as supplied. Repairs may be carried out only by the manufacturer.

Type 2: These parts are Type 1 parts with specific restrictions. Only the modifications indicated in the homologation may be carried out. Repairs are allowed only in the range described in the homologation.

Type 3: These parts are unrestricted, provided that they are used as designed by the manufacturer and do not fulfil any additional function.

The above-mentioned parts classification and the user manual form part of the homologation, both documents will be supplied by the respective manufacturer.

The adding of colour or thin adhesive film up to a thickness of 0.5 mm is not considered as a modification, provided that the colour or film fulfils only an optical function.

2.7.2 Standard mounting parts

Standard mounting parts, such as screws, nuts, bolts, washers and lock washers, are considered as Type 3 parts unless specifically mentioned in the homologation. They may be replaced with equivalent or superior standard parts.

The thread type, size, thread engagement and pitch must remain the same.

In case the connection remains intact and the standard mounting part doesn't fulfil any additional functionality, the thread type and pitch are free and the size and length may be increased.

The use of locking wire is permitted.

Any type of standard mounting part which has an influence on the car set-up is considered as a Type 1 part unless specifically mentioned in the homologation.

Only Type 3 washers may be removed.

Washers may be added only for facilitating and improving mechanical installation. They may influence the set-up of the car only when specifically mentioned in the homologation.

2.7.3 Protections

Heat protections, mechanical protections (such as abrasion protection or tape) and protections for driver comfort may be added, provided that their sole function is the protection of the relevant element and unless specifically mentioned in the homologation.

2.7.4 Bodywork

The modification of bodywork parts and bodywork supports is allowed only to ensure proper installation despite manufacturing tolerances.

2.7.5 Quick couplings

The use of quick couplings for brake, clutch and fuel lines is allowed, provided that FIA-approved dry couplings are used.

2.7.6 Tape

The forward face of the radiators or stone guards which are more than 150mm inside the side pod air ducts may be partially covered with adhesive for the sole purpose of optimising engine temperature.

It is forbidden to reduce the inlet surface of the side pod air ducts.

Front and rear brake ducts may be partially or fully covered with tape for the sole purpose of optimising brake temperatures.

In addition to above, tape may be applied to fasteners or any component surface. In all cases, it must be clear that the tape has no function other than securing the fixings, colouring or protecting the parts to which it is attached. Apart from securing fasteners, it is not permitted to apply tape to cover a junction between components, holes or cavities.

ARTICLE 3 : BODYWORK AND DIMENSIONS

3.1 Definitions

3.1.1 Geometrical planes

Reference plane: a nominally horizontal plane sitting at the bottom of the sprung part of the car, with the exception of the plank assembly defined in Article 3.7.4.

Centre plane: a vertical plane, which is perpendicular to the reference plane and aligned with the direction of motion of the car. The centre plane is the nominal plane of symmetry of the car.

Plane A-A (also referred to as "A-A"): a plane which is perpendicular to both the reference and centre plane, which lies on the contact surface between the frontal anti intrusion panel as per Article 15.5.4 and the frontal impact absorbing structure as per Article 15.6.5.

Plane C-C (also referred to as "C-C"): a plane which is parallel to A-A, whose position is defined in Article 15.4.3.

3.1.2 Reference Volumes, Surfaces and CAD geometries

"Reference Volumes", "Reference Surfaces" and "Reference CAD geometries" are used throughout the Technical Regulations for geometrical and design constraints.

For convenience, Reference Volumes are preceded by the prefix "RV-", Reference Surfaces by the prefix "RS-" and Reference CAD geometries by the prefix "RC-".

The position of the above mentioned items in space are defined using the car's coordinate system. The coordinates are mentioned in the relevant articles or planes / coordinate systems are included in the CAD model.

A maximum deviation of ± 0.5 mm from defined Reference CAD geometries will be permitted.

3.1.3 Coordinate system and references

A right-handed Cartesian (X, Y, Z) coordinate system will be used in these regulations, defined in the following way:

- a. The X axis is in the rearwards longitudinal direction and is parallel to the reference and car centre planes. Depending on the regulation in question, the local origin can vary, and the following convention is used:
 - i. $X_A=0$ mm is defined to be on plane A-A
 - ii. $X_B=0$ mm is defined to be on plane B-B
 - iii. $X_C=0$ mm is defined to be on plane C-C
 - iv. The planes $X_F=0$ and $X_R=0$ are defined as the planes which respectively pass through the origin of the two front or two rear wheels' coordinate systems, with the wheels in the straight ahead position.
 - vi. $X_{PU}=0$ mm is defined to pass through the forward most mounting face of the studs connecting the power unit to the survival cell, as defined in Article 5.3.2.
- b. The Y axis is normal to the X axis, parallel to the reference plane, and pointing to the right hand side of the car. $Y=0$ mm is defined to be on the car centre plane.
- c. The Z axis is normal to the reference plane and points upwards. $Z=0$ mm is defined to be on the reference plane

3.1.4 Further conventions

- a. If no units are specified, it is implicit the unit will be in millimetres
- b. Planes will be referred to as the axis to which they are normal to (e.g. X-plane or $X_A=300$ plane).

- c. Unless otherwise specified, the positive side of the Y axis is used in the various articles and it is implicit that a symmetrical rule applies for the other side of the car. The terms “inboard” or “outboard”, when used in reference to the Y coordinate, respectively refer to closer to or further away from the car centre plane.
- d. Unless otherwise specified any measurements and references will be with the wheels in the straight ahead position (the wheel rotation axis lying within an X plane).
- e. Unless otherwise specified, when a viewing direction is stated, “front” and “rear” are parallel to the X axis, “side” is parallel to the Y axis (in the direction towards the car centre plane) and “above”, “below” and “plan” are parallel to the Z axis.

3.1.5 Wheel Coordinate System

A Cartesian (X_W , Y_W , Z_W) coordinate system will be used for each wheel, defined in the following way:

- a. The X_W axis lies on the inboard plane of the wheel rim, passes through its rotational axis and points in the rearward longitudinal direction. $X_W=0$ mm is defined to be on the wheel rotational axis. The X_W axis is parallel to the car centre plane and to the reference plane, with the wheel in the straight-ahead position.
- b. The Y_W axis is normal to the inboard plane of the wheel rim and points towards the car centre plane. $Y_W=0$ mm is defined to be on the inboard plane of the wheel rim. Referring to this coordinate, the terms “inboard” or “outboard” respectively refer to closer to or further away from the car centre plane.
- c. The Z_W axis is normal to both the X_W and Y_W axes and points upwards. $Z_W=0$ is defined to be on the wheel rotational axis.
- d. Once the wheel axis system is defined as above, then it maintains a fixed orientation relative to the suspension upright at all other suspension articulation points.

3.1.6 Symmetry

All bodywork must be nominally symmetrical with respect to $Y=0$. Consequently, and unless otherwise specified, any regulation in Article 3 concerning one side of the car will be assumed to be valid for the other side of the car and references to maximum permissible numbers of components in Article 3 will also refer to the one side of the car.

3.2 Overall dimensions

3.2.1 Height

No part of the bodywork may be higher than $Z=960$.

3.2.2 Width

- a. The overall width of the car including complete wheels shall not exceed 1850mm, with the steered wheels in the straight ahead position.
- b. Bodywork width between $X_F=0$ and $X_R=0$ must not exceed $Y=750$.
- c. Bodywork width behind $X_R=0$ must not exceed $Y=550$.

3.2.3 Overhangs

No part of the car may be rearward of $X_R=830$ and forward of $X_A=-1100$.

3.2.4 Wheelbase

The distance between the planes $X_F=0$ and $X_R=0$ must be no more than 3100mm and no less than 2800mm.

3.3 Front Wing (FW)

3.3.1 Front Wing Main Plane and Front Wing Flap dimensions

The Front Wing Main Plane and the Front Wing Flap must be situated in the volume **RV-FW**.

3.3.2 Exclusion zone

Except for the components below, no bodywork is allowed forward of $X_F=-350$

- a. Homologated frontal impact absorbing structure.
- b. Homologated Front Wing Pillars
- c. Homologated Front Wing Main Plane.
- d. Homologated Front Wing Endplates
- e. Homologated Front Wing Flap

3.3.3 Front Wing Main Plane (FWMP)

- a. The Front Wing Main Plane must conform to the surfaces given in **RC-FWMP**, and must be trimmed to the inner surface of the Front Wing Endplate. A fillet radius, up to 5mm, may be applied along the intersection between these surfaces. Local deviations from the given surfaces are permitted for the sole purpose of facilitating the fixation of the Front Wing Flap.
- b. The local reference plane Z_{FW-MP} defined in **RC-FWMP** must lie on $Z=0$.
- c. With the exception of the lateral extremities (the Front Wing Endplates) and the fixation points (inserts / holes) for the homologated Front Wing Pillars and for the Front Wing Flap, the Front Wing Main Plane must be a single, smooth, rigid, continuous element without any slots, gaps, attachments or dividers in order that only one single continuous section may be contained within any cross section taken parallel to the car centre plane and normal to the reference plane.
- d. Local deviations from the given surfaces RC-FWMP are permitted for the sole purpose of facilitating the fixation of the Front Wing Flap and the Front Wing pillars to the Front Wing Main Plane.
- e. The Front Wing Pillars must conform the surfaces given in **RC-FW-PIL** and must be trimmed to the upper surface of the Front Wing Main Plane. A fillet radius, up to 5mm, may be applied along the intersection between these surfaces.
- f. Local deviations from the given surfaces RC-FW-PIL are permitted for the sole purpose of facilitating the fixation of the Front Wing Main Plane and the Front Impact Absorbing Structure to the Front Wing Pillars.

3.3.4 Front Wing Endplates (FWEP)

- a. The lateral extremities of the Front Wing assembly (the Front Wing Endplates) must be situated within the volume **RV-FWEP**.
- b. The surface **RS-FWEP-FP** must be entirely covered by the Front Wing Endplates when viewed from above.
- c. The surface **RS-FWEP-MIN** must be entirely covered by the Front Wing Endplates when viewed from the side.
- d. All external edges of the Front Wing Endplate must be at least 10mm thick and have a minimum radius of 5mm to prevent tyre damage to other cars.

- e. The Front Wing Endplates must be directly attached to the homologated Front Wing Main Plane (meaning no other parts are allowed between the homologated Front Wing Main Plane and the Front Wing Endplate).

3.3.5 Front Wing Flap (FW-FLAP)

- a. The Front Wing Flap must conform to the surfaces given in **RC-FW-FLAP**.
- b. The local reference plane $Z_{FW-FLAP}$ defined in **RC-FW-FLAP** must lie on $Z=0$.
- c. The Front Wing Flap may be trimmed, provided:
 - i. No part of **RS-FW-FLAP** is visible when viewed from above.
 - ii. The rearward most edge of the Front Wing Flap, when projected in Z on to the reference plane, must produce a single tangent continuous curve with no radius of curvature smaller than 200mm.
- d. The portion of the Front Wing Flap lying outboard of $Y=200$ may be adjustable for the sole purpose of adjusting front wing aerodynamic load.
- e. The axis of rotation of the adjustable part of the Front Wing Flap must conform to the axis given in **RC-FW-FLAP**, and the rotation range is +12 deg and -4 deg about this axis.
- f. The portion of the Front Wing Flap lying inboard of $Y=200$ must remain fixed.
- g. No holes, apertures or slots are permitted in the Front Wing Flap, and no gurneys (trim tabs) may be added to the Front Wing Flap.
- h. Minimal geometry may be added inside of **RV-FW-FISHPLATE** for the purposes of:
 - i. Providing a sealed bearing surface between the adjustable and fixed portions of the Front Wing Flap.
 - ii. Forming a rigid connection between the Front Wing Main Plane or Front Wing Pillars and the fixed portion of the Front Wing Flap.
- i. For the avoidance of doubt, the adjustment permitted under this Article is only allowed when the car is stationary and by the use of a tool, and in accordance with the Sporting Regulations.
- j. Local deviations from the given surfaces are permitted for the sole purpose of facilitating the fixation of the Front Wing Flap to the Front Wing Main Plane.

3.4 Front Bodywork (FRT)

3.4.1 Nose and Chassis

- a. With the exception of the Secondary Roll Structure and its fairing defined within **RV-SRS-FR-MAX**, no bodywork forward of $X_c=-410$ may be above the surface **RS-FRT-UPR**.
- b. A transparent windscreen, that measures less than 30mm in Z, less than 300mm in Y, and is no more than 3mm thick, may be fixed to the forward face of the cockpit opening and may extend above **RS-FRT-UPR**.
- c. When viewed from above, no part of **RS-FRT-MIN** may be visible.
- d. In side view, there must be no bodywork within the volume **RV-FRT-LWR**.
- e. In plan view, there must be no bodywork within the volume **RV-FRT-EXCL**. This is with the exception of:
 - i. Rear View Mirrors
 - ii. Front Wing assembly defined in Article 3.3
 - iii. Front Wheel Bodywork defined in Article 3.9

3.4.2 Sidepod Leading Edge (SPOD-LE)

Bodywork declared as “Sidepod Leading Edge” must lie within **RV-SPOD-LE** and must be arranged such that when viewed from above, no part of **RS-SPOD-LE** may be visible.

3.4.3 Front Bodywork shape

Except for the Front Wing assembly defined by Article 3.3, the attachment of the frontal impact-absorbing structure, the cockpit rim edge, the Rear View Mirrors, the rollover structures, the inside of the cockpit and a transparent windscreen, each external X-plane and Y-plane cross-section forward of $X_C=-300$ and above $Z=100$ must form one tangent continuous curve on its external surface. With the exception of radiator duct surfaces, the tangent continuous curve of each external X-plane cross-section may not contain any radius less than 10mm.

3.5 Rear Bodywork (RBW)

3.5.1 Rear Exclusion Zone

Except for the homologated components below, no bodywork is allowed rearward of $X_{PU}=0$

- a. Rear Impact Structure and Jacking Points
- b. Beam Wing and Upper Rear Wing
- c. Rear Wing Endplates and Endplate Winglets
- d. Rear Lights
- e. Rear towing device
- f. Floor and Diffuser
- g. Sidepods and Engine Cover
- h. Plank
- i. Rear Wheel Bodywork

3.5.2 Space for Power Unit and intake system

The car must be designed such that a Power Unit and intake system, bellhousing and gearbox with the dimension of **RV-ENG-TEMP** may be fitted.

Once the relevant bodywork surfaces are defined in accordance with present Technical Regulations, if necessary for the installation of Power Unit, bellhousing or gearbox, it must be possible to add local extensions to the defined bodywork.

3.5.3 Space for exhaust system

The bodywork must be designed such that an exhaust system including a cylindrical muffler with a diameter of 150 mm and a length of 500 mm may be fitted on either side of the car.

3.5.4 Chassis Mid (CH-MID)

In the area between XB and XPU no bodywork may lie

- a. Above a plane passing by $[Y, Z] = [75, 960]$ and $[400, 615]$
- b. Above $Z=790$
- c. outboard of $Y=350$

except for the homologated components below:

- i. Secondary roll structure
- ii. Floor and Diffuser
- iii. Sidepods and Engine Cover

iv. Rear View Mirrors

3.5.5 Engine Cover (EC)

Bodywork declared as “Engine Cover” must:

- a. Lie within **RV-RBW-EC**.
- b. Be arranged such that when viewed from the side, no part of **RS-RBW-EC** may be visible.

3.5.6 Sidepod (SPOD)

Bodywork declared as “Sidepod” must lie within **RV-RBW-SPOD**.

3.5.7 Rear Bodywork shape

- a. Bodywork outboard of $Y=25$ and within the volumes defined as **RV-RBW-EC** and **RV-RBW-SPOD**, must produce no more than a single tangent continuous curve when intersected with any X plane. This tangent continuous curve may not contain any radius less than 50mm.
- b. The surfaces lying within **RV-RBW-EC** and **RV-RBW-SPOD**, which are forward of $X_R=-360$ must not contain any apertures (other than those permitted by Article 3.5.8) or contain any vertical surfaces which lie parallel to the plane C-C.

3.5.8 Apertures

Once the relevant bodywork surfaces are defined in accordance with Article 3.5.7, the following apertures may be added:

- a. A single aperture on either side of the car centre plane for the purpose of the exhaust exit. The bodywork edge of this aperture may have a maximum distance of 10mm to any point lying on the circumference of the exhaust pipe.
- b. Apertures on either side of the car centre plane for the purpose of allowing suspension members and driveshafts to protrude through the bodywork. No such aperture may have an area greater than 5,000mm² when projected onto the surface itself. No point on an aperture may be more than 100mm from any other point on the aperture.
- c. For the sole purpose of allowing cooling flow exits, apertures may be added on either side of the car centre plane provided they lie within **RV-RBW-APERTURE**. The total area (per side of the car) of such apertures may be no greater than 100,000mm². Furthermore, any apertures added must be arranged such that, when viewed from above, no part of **RS-RBW-APERTURE** may be visible through the aperture and any underlying part of the car exposed by application of an aperture must lie no further than 50mm normal to the untrimmed surface. For the avoidance of doubt, no part of the car exposed by application of an aperture may lie external to the untrimmed surface.

3.5.9 Floor Stays

Devices for the sole purpose of connecting the floor to the chassis may pass through the bodywork. The devices and passages through the bodywork must have a circular cross section with a diameter no greater than 5 mm and 7 mm respectively or a rectangular cross section of 25 mm x 2 mm and 30 mm x 5 mm respectively.

3.6 Rear Wing

3.6.1 Beam Wing

The Beam Wing must conform to the shape given in **RC-RW-BEAM**. Furthermore:

- a. The local reference $Z_{RW-BEAM}$ plane defined in **RC-RW-BEAM** must be on $Z=0$.
- b. The local reference $X_{RW-BEAM}$ defined in **RC-RW-BEAM** must lie on $X_R=0$.
- c. Except for fixations and the rear light installation, no holes, apertures or slots are permitted in the Beam Wing.
- d. No gurneys (trim tabs) may be added to the Beam Wing.
- e. The lateral extremities of the Beam Wing may be trimmed for the sole purpose of connecting to the Rear Wing Endplates. A fillet radius, up to 5mm, may be applied along the intersection between these surfaces.
- f. When connected to the Rear Wing Endplates, no part of the Beam Wing may be visible when viewed from the side.
- g. Minimal geometry may be added inboard of $Y=100$ for the sole purpose of rigidly mounting the Beam Wing.
- h. Local deviations from the given surfaces are permitted for the sole purpose of facilitating the fixation of the Rear Wing Pillars to the Rear Wing.

3.6.2 Upper Rear Wing

The two Upper Rear Wing elements must each conform to the shape and relative position as defined in **RC-RW-UPPER**. Furthermore:

- a. The local reference $Z_{RW-UPPER}$ plane defined in **RC-RW-UPPER** must lie on $Z=0$.
- b. The rotational axis defined in **RC-RW-UPPER** must lie at the intersection of planes $X_R=605$ and $Z=830$.
- c. Other than the nominal position described at point a., the upper rear wing assembly can only be adjusted in two additional discrete positions resulting by its rotation, limited to ± 3.0 degrees, around the axis described in b.
- d. No holes, apertures or slots are permitted in any surface of the Upper Rear Wing elements in contact with the external air stream.
- e. A fullspan gurney (trim tab) of up to 5mm may be fitted to the trailing edge of the upper surface of the rearmost section. For the sole purpose of providing a mounting face for this gurney, local modifications to this element are permitted, provided such changes lie within a region 15mm forwards of the trailing edge, only comprise material removal and the minimum thickness remains greater than 1.5mm.

Additionally, a central separator must be fitted between the two Upper Rear Wing elements, which must:

- f. Be made from homogeneous metallic material.
- g. Have a minimum thickness of 2mm, a maximum thickness of 15mm.
- h. Be rigidly fixed to both rear wing elements inside of $Y=25$.
- i. Not allow any displacement (except normal to $Y=0$) of one rear wing element relative to the other one.
- j. Local deviations from the given surfaces are permitted for the sole purpose of facilitating the fixation of the central separator.

3.6.3 Rear Wing Endplates (RWEF)

Bodywork declared as "Rear Wing Endplate" must:

- a. Lie within **RV-RWEF-BODY**.
- b. Be a single volume with no apertures.
- c. In any X or Z plane contain only one closed section.
- d. When projected in Y on to $Y=0$, have an area greater than $150,000\text{mm}^2$.
- e. Be arranged such that when viewed from the side, no part of **RS-RWEF-SIDE** may be visible.
- f. The leading edge of the Rear Wing Endplate below $Z=750$ must have a minimum radius of 6.0mm when viewed from outboard and a minimum radius of 3.0mm when viewed from inboard, assessed normal to the leading edge.

3.6.4 Rear Wing Endplate Winglet (RWEF-WLET)

The Rear Wing Endplate Winglet must conform to the shape given in **RC-RWEF-WLET** and be trimmed and solidly attached to the outboard surface of the Rear Wing Endplate. A fillet radius, up to 5mm , may be applied along the intersection between these surfaces. Local deviations from the given surfaces are permitted for the sole purpose of facilitating the fixation of the Rear Wing Endplate Winglet and the Rear Wing Endplate.

Furthermore:

- a. The local reference plane $X_{\text{RWEF-WLET}}$ defined in **RC-RWEF-WLET** must lie on $X_R=0$.
- b. The local reference plane $Y_{\text{RWEF-WLET}}$ defined in **RC-RWEF-WLET** must lie on $Y=540$.
- c. The local reference plane $Z_{\text{RWEF-WLET}}$ defined in **RC-RWEF-WLET** must lie on $Z=0$.

3.7 Floor and Diffuser

Compliance with this Article must be demonstrated with all unsprung parts of the car removed.

3.7.1 Step and Reference planes

All sprung parts of the car situated between $X_C=-1200$ and $X_R=-840$, which are visible from underneath, must form surfaces which lie on one of two parallel planes, the reference plane or the step plane or in the transition area between these two planes. This does not apply to any parts of the survival cell lying between $X_C=-1200$ and $X_C=-620$, and Rear View Mirrors. Additionally:

- a. The step plane must be 50mm above the reference plane.
- b. The surface formed by all parts lying on the reference plane must cover the surface defined in **RS-REF-MIN**, have a maximum width $Y=250$ and be made of wood between 9.5mm and 10.5mm thick.

All parts lying on the reference and step planes, in addition to the transition between the two planes, must produce uniform, solid, hard, continuous, rigid (no degree of freedom in relation to the body/chassis unit), impervious surfaces under all circumstances.

The surface lying on the reference plane may be curved upwards at its boundaries with an arc of constant curvature whose radius of curvature is no greater than 25mm , with no inflection, which is tangential to the surface and applied perpendicular to the boundary. In no case may the arc start further than 25mm from the boundary (when measured on the surface and perpendicular to this boundary).

Where the vertical transition meets the surfaces on the step plane a radius no greater than 25mm is permitted (a radius in this context will be considered as an arc of constant curvature applied perpendicular to the boundary and tangential to both surfaces).

The surfaces lying on the step plane which do not meet one of the vertical transitions may be curved upwards at their boundaries with an arc whose radius of curvature is no greater than 650mm at any point, with no inflection, which is tangential to the surface and applied perpendicular to the boundary. In no case may the arc start further than 100mm from the boundary (when measured on the surface and perpendicular to this boundary).

The surface lying on the reference plane, the surfaces lying on the step plane, the vertical transitions between them and any surfaces rearward of the surfaces lying on the reference or step planes, must first be fully defined before any radius can be applied. Any radius applied is still considered part of the relevant surface.

3.7.2 Tolerances

To help overcome any possible manufacturing problems, and not to permit any design which may contravene any part of these regulations, dimensional tolerances are permitted on bodywork situated between $X_C=-1200$ and $X_R=-600$.

A vertical tolerance of +/- 3 mm is permissible across the surfaces lying on the reference and step planes and a horizontal tolerance of 3 mm is permitted when assessing whether a surface is visible from beneath the car.

3.7.3 Floor and Diffuser shape

- a. Bodywork declared as "Floor" and "Diffuser" must lie within **RV-FLOOR-DIFFUSER**.
- b. All such bodywork lying rearward of $X_R=-840$ must be designated as "Diffuser", be included into **RC-DIFFUSER** and include the surfaces given in **RC RS-DIFFUSER**
- c. It is allowed to add to **RC-DIFFUSER** (per side):
 - i. A single Diffuser Blister which must:
 - Exist entirely between $X_R= -320$ and $X_R= 200$, and below $Z= 200$.
 - Lie entirely between the Diffuser lower surface and a 10mm external offset.
 - Intersect the Diffuser lower surfaces around its entire periphery.
 - Only comprise convex curvature, with a minimum radius of 20mm.
 - be trimmed to the Diffuser, such that no overlapping surfaces remain,
 - have a fillet radius, no smaller than 20mm, along the intersection between these surfaces
 - ii. A bodywork surface lying within **RV-RBW-DIFFUSER** which complete surface, when intersected with any Z-plane, must produce only a single section that is continuous, closed and with all parts of the section visible from either above or below.
 - iii. A single fin lying within **RV-DIFFUSER-LOW-FINS** which complete surface, when intersected with any Z-plane, must produce only a single section that is continuous, closed and with all parts of the section visible from either above or below.
 - iv. A single fin lying within **RV-DIFFUSER-TOP-FINS** which complete surface, when intersected with any Z-plane, must produce only a single section that is continuous, closed and with all parts of the section visible from either above or below.

Furthermore:

- d. All such bodywork lying forward of $X_R=-840$ must be designated as "Floor" and respect Articles 3.7.1 and 3.7.2.
- e. When viewed from the side, all Floor surfaces must be visible.
- f. When viewed from below, the Diffuser may be trimmed for different tyre dimensions within the region bounded by the annotated line "**DIFFUSER-TRIM**".

- g. A fillet radius of up to 50mm may be applied to the top surface of the Floor and Diffuser to blend to the Front and Rear Bodywork surfaces.

3.7.4 Plank

Beneath the surface formed by all parts lying on the reference plane, a rectangular plank must be fitted. This plank must be made from at least two pieces and must:

- a. Extend from $X_C=-1190$ to $X_R=-400$.
- b. Be made from wood or an alternative uniform material approved by the FIA during the homologation process.
- c. Have a width of 300mm with a tolerance of +/- 2mm.
- d. Have a minimum thickness of 2.0 mm.
- e. Have a uniform thickness of at least 5.0 mm when new.
- f. Have no holes or cut outs other than those necessary to fit the plank to the car.
- g. Have three precisely placed 80mm diameter holes at the following positions on $Z=0$:
 - i. $[X_R=-2025, 90]$
 - ii. $[X_R=-2025, -90]$
 - iii. $[X_R=-525, 0]$
- h. Be installed symmetrically to $Y=0$ in such a way that no air may pass between it and the surface formed by the parts lying on the reference plane.

The front and rear edge of a new plank may be chamfered over a distance of 50mm to a depth of 3mm.

The structure located above the three holes described by point g. should be rigid.

In order to establish the conformity of the plank after use its thickness will only be measured around the four 80mm diameter holes, the minimum thickness must be respected in at least one place on the circumference of all four holes.

In order that each plank is readily identifiable by scrutineers, each one produced must be permanently marked with a unique number which is accessible for verification at any time.

3.7.5 Floor and Plank protection

For the sole purpose of protecting the Floor and Plank against excessive wear, the materials prescribed in Articles 3.7.1 and 3.7.4 may be substituted in the following area:

- a. Below $Z=50$, inside of $Y=250$, and between $X_C=-1200$ and $X_C=-1100$

The substituted material must:

- b. comply to dimensional requirements of Article 3.7
- c. be approved by FIA during the homologation process.

3.8 Roll Structure Fairing

3.8.1 Main Roll Structure (MRS) Fairing

The Main Roll Structure must have a non-structural fairing attached to it, complying to the following:

- a. Lie within the **RV-MRS-COVER**
- b. Cover at least the surface of **RS-MRS-MIN** with the exception of the opening required by Art. 15.2.6.

- c. Within 20mm of all Z-sections through the leading edge outside of **RS-MRS-MIN** surfaces must only comprise convex curvature with a minimum radius of 5.0mm and inside of **RS-MRS-MIN** a minimum radius of 5.0mm.

3.8.2 Secondary Roll Structure (SRS) Fairings

The Secondary Roll Structure and the Secondary Roll Structure Fixation may have a non-structural fairing surrounding it. These fairings must lie within **RV-SRS-FR-MAX**. A fillet radius may be applied between these fairings and the adjoining chassis and bodywork surfaces.

3.9 Wheel Bodywork

3.9.1 General principles

Geometry declared as “Front Wheel Bodywork” and “Rear Wheel Bodywork” must comprise of all the components described in Articles 3.9.2/3.9.3 and Articles 3.9.4/3.9.5 respectively.

With the exception of Rim Blanking and minimal flexible parts for the sole purpose of allowing an aerodynamic seal to be maintained to the suspension members and wheels, the Wheel Bodywork must:

- a. Be rigid and rigidly secured to the suspension uprights (rigidly secured means not having any degree of freedom).
- b. Not be rigidly secured to the suspension members.

3.9.2 Front Brake Ducts

Bodywork declared as “Front Brake Ducts” must comply to the following requirements:

- a. Lie within the volume **RV-FBD**
- b. With the exception of minimal apertures to allow passage of suspension elements, fully obscure **RS-FBD** when viewed parallel to the Y_w axis from inboard.
- c. Be designed such all air enters the Front Brake Duct forward of $X_w=-100$.

3.9.3 Front Rim Blanking

On each front wheel, a single Rim Blanking panel must be rigidly secured to the inside of the front wheel. This panel must have the same rotational velocity as the wheel it is connected to and be designed to form an aerodynamic seal between the inside of the wheel rim and the outside.

3.9.4 Rear Brake Ducts

Bodywork declared as “Rear Brake Ducts” must comply to the following requirements:

- a. Lie within the volume **RV-RBD**
- b. With the exception of minimal apertures to allow passage of suspension elements, fully obscure **RS-RBD** when viewed parallel to the Y_w axis from inboard.
- c. Be designed such all air enters the Rear Brake Duct forward of $X_w=-100$.

3.10 Aerodynamic Influence

Any specific part of the car influencing its aerodynamic performance (with the exception of non-structural shrouds protecting wheel tethers which are being used solely for this purpose):

- a) Must comply with the rules relating to bodywork.
- b) Must be rigidly secured to the entirely sprung part of the car (rigidly secured means not having any degree of freedom).

Any specific part of the car influencing its aerodynamic performance must remain immobile in relation to the sprung part of the car.

Any device or construction that is designed to bridge the gap between the sprung part of the car and the ground is prohibited under all circumstances.

No part having an aerodynamic influence and no part of the bodywork, with the exception of the plank in Article 3.7.5 above, may under any circumstances be located below the reference plane.

Any car system, device or procedure which uses driver movement as a means of altering the aerodynamic characteristics of the car is prohibited.

3.11 Bodywork Flexibility

- 3.11.1** Bodywork may deflect no more than 5mm vertically when a 50 kg load is applied vertically to it 860mm forward of the front wheel centre line and 550mm from the car centre plane, this point being the centre of the below described adapter. The load will be simultaneously applied on both sides of the front wing main plane in a downward direction using a rectangular adapter 300mm long and 150mm wide with the 300mm edges running parallel to the car centre plane. The adapter must follow the shape of the front wing in the above defined area and the teams must supply the latter when such a test is deemed necessary. During the test the car must sit on the plank and the deflection is measured on both sides of the front wing main plane and at the car centre plane, the car centre plane figure being deducted from the LHS and RHS figures.
- 3.11.2** Any bodywork facing the ground must remain in compliance with Article 3.7 when a load of 10kg is applied vertically to it at its outermost point directly in front of the rear wheels. The load will be simultaneously applied on both sides of the car in a downward direction.
- 3.11.3** In order to ensure that the requirements of Article 3.9 are respected, the FIA reserves the right to introduce further load/deflection tests on any part of the bodywork which appears to be (or is suspected of), moving whilst the car is in motion.

ARTICLE 4 : WEIGHT

4.1 Minimum weight :

The minimum weight has to be defined in the Sporting Regulations of each Formula Regional Championship.

The minimum weight may not be less than the homologation weight (for each rolling chassis and engine combination as per Article 3.1 of the FIA Formula Regional 2nd Gen Homologation Regulations).

4.2 Ballast :

Ballast can be used provided it is secured in such a way that tools are required for its removal. It must be possible to fix seals if deemed necessary by the scrutineers.

4.3 Adding during the race :

The adding to the car during the race of any liquid or other material whatsoever or the replacement during the race of any part with another materially heavier is forbidden.

ARTICLE 5: POWER UNIT

5.1 Power Unit homologation:

Only Power Unit which have been homologated in accordance with the Formula Regional 2nd Gen Homologation Regulations may be used during an event.

All such Power Units should be delivered in such a condition that the seals can be fitted.

5.2 General power unit specification:

5.2.1 Only 4-stroke (Otto principle) engines with reciprocating pistons are permitted.

5.2.2 Turbocharged engines are permitted.

5.2.3 The engine may be structural or be fitted with an additional space frame.

5.2.4 The power unit must supply a stable electrical output of at least 360W, calculated at 12V and engine revs above 2000rpm, through the standard connector defined by Article 8.7.

5.3 Main Power Unit and intake system dimensions:

5.3.1 The height of the crankshaft rotational axis must be no less than Z=125.

5.3.2 The Power Unit -to-chassis mounting points must be arranged in accordance with Drawing 1.

5.3.3 The Power Unit including bell housing or space frame and intake system must comply with the maximum dimensions given in **RV-ENG-TMP**. If necessary for the installation of the Power Unit, local extensions may be added.

5.3.4 All air feeding the engine must pass through the principal roll structure of the car.

5.4 Power Unit maximum weight:

The complete weight of the Power Unit homologation perimeter, as defined in the FIA Formula Regional 2nd Gen Homologation Regulations Article 3.7, may be no more than 150.0kg.

5.5 Power Unit Control Unit:

5.5.1 The ECU and Power Unit loom must provide the common connector defined by Article 8.7.

The ECU must provide the datalogger functionality as defined in Article 8.6.

5.5.2 The Power Unit manufacturer must provide a mechanism that allows the scrutineers to accurately identify the ECU software version loaded.

5.5.3 The following channels must be available via CAN for the chassis data logging system:

- Throttle pedal position
- Engine rpm
- Auxiliary battery voltage
- Water temperature
- Oil temperature
- Oil pressure
- ERS and Power Unit error codes.

5.5.4 The following channels, when they exist, must be available for Power Unit support and scrutineering purposes only:

- Ignition cut
- Ignition timing
- Injection timing
- Fuel mass
- Global fuel mass correction factor
- Lambda
- Air temperature
- Airbox/inlet pressure
- Throttle valve position
- MGU: Speed and temperatures (winding, rotor, bearings)
- Inverter: Power Module temperature, Iq and Id current and existing diagnostic channel
- ES: State of charge, cells temperature, voltage, current and existing diagnostic channel.
- DCDC: Voltages, currents, temperatures and existing diagnostic channels.

5.6 General electrical safety:

The maximum working voltage on the car must never exceed 60V DC or 30V AC.

5.7 Power circuit:

The outer covering of cables and harness of the traction circuit not within enclosures or behind barriers shall be marked in purple or orange.

Power circuit cables and harnesses must be inside the bodywork.

5.8 Energy Store (ES)

Liquid cooling is forbidden.

The ES must be surrounded by a fire proof enclosure (V0 level of acceptance respecting the "UL94" US standard).

The technology for the ES is free but it must have the suitable UN certification for transportation.

The Energy Store must be equipped with a contactor which will isolate the ES cells of the other parts of the car when a shutdown is requested.

The Energy Store must be equipped with a fuse to protect the ERS in case of a short circuit. The fuse shall be located as close as possible to the ES cells.

The energy store must be equipped with a BMS. Should it be required due to the technology of the ES, the ES must be fitted with a pressure release valve. The vapour exiting this valve must be directed outside the cockpit.

External charging of the Energy Store during pitstops is prohibited.

5.9 Motor Generator Unit (MGU)

The MGU must be mechanically linked to the engine before the main clutch.

5.10 Push to pass System

Cars may be equipped with a system to temporarily increase the power output of the PU. The additional power may only increase the maximum output of the PU by no more than 25 bhp at any given engine speed, must be time limited to no more than 15 seconds in any single application and its activation must only be commanded by direct driver input.

Whilst the system is active the maximum engine power output may be temporarily above the homologated engine power output.

The use of this system and its primary features are subject to the approval of the FIA Single Seater Department.

ARTICLE 6 : PIPING AND FUEL TANKS

6.1 Fuel tanks :

6.1.1 The fuel tank must be a single rubber bladder conforming to or exceeding the specifications of FIA Standard FT3-1999, the fitting of foam within the tank however is not mandatory. A list of approved materials may be found in FIA Technical List No.1 (List of fuel bladders homologated according to the FIA Standards FT3-1999, FT3.5-1999, FT5-1999) on the FIA website.

The fuel system must comply to the fuel system guidelines. Details of the guidelines can be found in the Appendix to the Technical Regulations.

6.1.2 All fuel on board the car must be stored within the following limits:

- a. Ahead of $X_{PU}=0$.
- b. Rearward of RS-FWD-FUEL-LIMIT.
- c. Inboard of $Y=400$.

6.1.3 No rubber bladders shall be used more than five years after the date of manufacture, unless inspected and recertified by the manufacturer for a period of up to another two years.

6.1.4 The capacity of the fuel tank must be at least 70 litres.

6.2 Fittings and piping :

6.2.1 All apertures in the fuel tank must be closed by hatches or fittings which must:

- Be secured to metallic or composite bolt rings bonded to the inside of the bladder.
- Have a total in contact with the fuel which does not exceed 30000 mm².
- Have bolt hole edges no less than 5 mm from the edge of the bolt ring, hatch or fitting.
- Attach directly to the fuel cell and have no part of the survival cell structure included in the closure.
- Be secured with multiple fasteners in such a way that the absence of any single fastener does not compromise the security of the closure. Exceptionally, circular fittings smaller than 30 mm diameter may be secured with a single nut on the full diameter provided that mechanical secondary locking is provided.

Where the fuel cell is attached to the survival cell, the attachment must be separate from the survival cell without compromising the integrity of the fuel bladder.

No seam on the bladder may be less than 25 mm in length.

All hatches and fittings must be sealed with the gaskets or "O" rings supplied with the tank.

6.2.2 All fuel lines between the fuel tank and the engine must have a self sealing breakaway valve. This valve must separate at less than 50% of the load required to break the fuel line fitting or to pull it out of the fuel tank.

6.2.3 No lines containing fuel, cooling water or lubricating oil may pass through the cockpit.

6.2.4 All lines must be fitted in such a way that any leakage cannot result in the accumulation of fluid in the cockpit.

6.2.5 No hydraulic fluid lines may have removable connectors inside the cockpit.

6.2.6 When flexible, all lines must have threaded connectors and an outer braid which is resistant to abrasion and flame.

6.2.7 All fuel and lubricating oil lines must have a minimum burst pressure of 41bar at the maximum operating temperature of 135°C.

- 6.2.8 All hydraulic fluid lines which are not subjected to abrupt changes in pressure, with the exception of lines under gravity head, must have a minimum burst pressure of 408bar at the maximum operating temperature of 204°C when used with steel connectors and 135°C when used with aluminium connectors.
- 6.2.9 All hydraulic fluid lines subjected to abrupt changes in pressure must have a minimum burst pressure of 816 bar at the maximum operating temperature of 204°C.
- 6.2.10 All components containing fuel at a pressure greater than 10bar must be located outside the fuel tank.

6.3 Crushable structure :

The fuel tank must be completely surrounded by a crushable structure, which is an integral part of the survival cell and must be able to withstand the loads required by the test in Article 18.3.

6.4 Tank fillers :

6.4.1 Tank fillers must not protrude beyond the bodywork. Any breather pipe connecting the fuel tank to the atmosphere must be designed to avoid liquid leakage when the car is running or if upside down and its outlet:

- Must not be less than 250mm from the cockpit opening;
- Must be placed where they would not be vulnerable in the event of an accident;
- Must not protrude beyond the surface of the bodywork;
- Must be fitted with a gravity actuated roll-over valve and a float chamber ventilation valve

6.4.2 All cars must be fitted with a self sealing connector which can be used by the scrutineers to obtain fuel from the tank.

This connector must be the type approved by the FIA.

6.5 Refuelling :

6.5.1 Refuelling at any time is only allowed through a self-sealing connector.

6.5.2 Refuelling during the race is forbidden.

6.5.3 Refuelling the car on the grid by any other means than by gravity from a maximum head of two metres above the ground is forbidden.

6.5.4 Any storage of fuel on board the car at a temperature of more than ten degrees centigrade below the ambient temperature is forbidden.

6.5.5 The use of any specific device, whether on board or not, to decrease the temperature of the fuel below the ambient temperature is forbidden.

ARTICLE 7 : OIL AND COOLING SYSTEMS

7.1 Location of oil tanks :

All oil storage tanks must be situated between the front wheel axis and the rearmost gearbox casing longitudinally, and if situated outside the main structure of the car they must be surrounded by a 10mm thick crushable structure.

No part of the oil reservoir for engine lubrication may be situated more than 200mm laterally from the car centre plane. The oil reservoir must be located between the rear face of the engine and the rear wheel centre line longitudinally.

7.2 Longitudinal location of oil system :

No other part of the car containing oil may be situated behind the complete rear wheels.

7.3 Catch tank :

When a car's lubrication system includes an open type sump breather, this breather must vent into a catch tank of at least 2 litres capacity.

The use of additional vent pipes for the purpose of venting a catch tank rearwards to the back of the car is not permitted. Measures must be taken to ensure that no liquid can leak from any aeration system.

7.4 Transversal location of oil system :

No part of the car containing oil may be more than 660mm from the car centre plane.

7.5 Oil replenishment :

No oil replenishment is allowed during a race.

7.6 Cooling fluids :

Only ambient air, water, anti-freeze and oil are permitted in the car cooling systems.

ARTICLE 8 : ELECTRICAL SYSTEMS

8.1 Starter:

A starter with an electrical or other source of energy carried aboard the car, and able to be controlled by the driver when seated normally, must be fitted.

The starter must be capable of starting the engine at all times.

An exception to this requirement may be granted if an MGU is fitted with enough capability.

8.2 Starting the engine :

A supplementary device temporarily connected to the car may be used to start the engine both on the grid and in the pits.

8.3 Auxiliary battery:

The auxiliary battery must be installed inside the survival cell, on the floor behind the driver's seat.

The use of a battery with any kind of lithium technology is only allowed if a BMS forms an integral part of the battery.

8.4 Energy Store (ES) position:

The ES must be located either in the survival cell or in a protected enclosure. In any case the ES must be isolated from the cockpit.

No part of the ES may lie:

- In front of the forward most point of the back of driver's seat
- Behind the engine
- More than 350mm from the car centre plane.

8.5 Accident data recorders :

All cars must be equipped with an accident data recorder approved according to FIA Standard 8872-2018 (Technical list n°88) which will have to be installed according to the "Installation specification for FIA-approved 8872-2018 accident data recorder (ADR)".

The relevant systems of the vehicle shall provide the inputs specified in the ADR's installation specifications and respective user manual.

The CAN protocol, PIN-out and led scheme are provided in the ADR manufacturer's user manual.

At any time following an accident or incident, the recorded data from the ADR device must be made available to the FIA when requested.

The competitor agrees that the data ownership rights of any and all data recorded by the ADR should be assigned to the FIA in perpetuity.

The following connections must be provided for the ADR:

- 2 pins for a 12V power supply (including ground)
- 2 pins for remote status light (including ground)
- 2 pins for CAN communication with the ECU

- 4 pins for external Ethernet or USB download connection, wired to a download connector, which is accessible without removing any parts

In order to give rescue crews an immediate indication of accident severity each car must be fitted with a warning light inside the cockpit which is connected to the ADR and visible while the driver is in the car.

8.6 Data logger, sensors, dashboard and/or steering wheel display:

8.6.1 Data logger

The chassis must be equipped with a data logging system.

The ECU must be used as the data logger.

It must be possible to restrict competitor access to at least the channels defined by Article 5.5.4. The channels must be stored for Power Unit support and scrutineering purposes.

8.6.2 Sensors

The chassis has to be equipped with the following sensors:

- Throttle Pedal position
- Brake pressure (one for each brake circuit)
- Wheel speed (4x wheels)
- Steering angle
- Gear position
- Up to 3-axial accelerometer
- Damper positions
- Clutch pressure
- Chassis powered On-Board-Camera (OBC) with the minimum specifications:
 - FIA approved installation
 - 1280x720 pixel @ 30 fps
 - Recording time: 70'- 80'
 - Data overlay from the vehicle data is strongly recommended

Additionally, the following sensors can be homologated:

- GPS unit

8.6.3 Dashboard/steering wheel display

The car must be equipped with a dashboard or steering wheel display. A functional check for the sensors mentioned in Article 8.6.2 must be possible only by using the dashboard or steering wheel display.

8.7 Electrical system connection interfaces:

The purpose of the regulations under Article 8.7 below is to minimise the effort when changing the make of Power Unit.

The connection interface between Power Unit and chassis loom, as defined by Appendix 2 is mandatory.

The sensor signals, mentioned in Appendix 2, may to be substituted by CAN signals. If required by the Power Unit or chassis manufacturer, direct sensor signals have to be provided.

8.8 Throttle fail safe :

Every car must be equipped with a throttle fail safe algorithm, which, in case throttle and brake pedal are pressed at the same time, overrides the throttle and cuts the engine or closes the throttle and cuts the power to the MGU.

The function and the parameter of the fail safe algorithm must be communicated to the FIA.

8.9 Marshalling System / FCY / VSC Interface:

The electrical system must be designed to provide within the chassis perimeter a connector with the following specifications:

- CAN H (common with ECU and ADR)
- CAN L (common with ECU and ADR)
- 12V
- GND

ARTICLE 9 : TRANSMISSION TO THE WHEELS

9.1 Gearbox homologation:

Only gearboxes which have been homologated in accordance with the Formula Regional 2nd Gen Homologation Regulations may be used during an event.

9.2 Four wheel drive :

Four wheel drive cars are forbidden.

9.3 Type of gearbox :

9.3.1 All cars must have six forward gears.

9.3.2 No forward gear ratio pair must be :

- a) Less than 12.75mm wide when measured across the gear tooth at the root diameter or any point 1mm above or below the root diameter. Above this area each side of the gear teeth may be chamfered by a maximum of 10°. In addition, a chamfer or radius not exceeding 2.0mm may be applied to the sides and the tip of the teeth.
- b) Less than 575g (excluding any integral shaft or collar). If an integral shaft or collar is to be excluded the mass of this may be shown by calculation assuming the gear to be 12.75mm wide and the shaft geometry to be the same as that where slide-on gears are used.

9.3.3 Gear ratios must be made from steel.

9.3.4 The rotational axis of the layshaft must be in line with the crankshaft's rotational axis. All other rotational axes must also be parallel to the reference plane.

9.3.5 From the clutch to the rear wheels there are only two pairs of reduction gears allowed per ratio (except for the reverse gear).

9.3.6 Transversal gearboxes are forbidden. Gear ratio pairs must be in front of an X-plane passing through the axis of the final drive.

9.3.7 Automatic gearboxes are prohibited.

9.3.8 Forced lubrication is forbidden.

9.4 Reverse gear :

All cars must have a reverse gear which, at any time during the event, can be selected while the engine is running and used by the driver when seated normally.

9.5 Traction control :

The use of traction control is forbidden.

9.6 Driveshafts :

Driveshafts must be made from steel. They must have an outside diameter no less than 24mm and an inside diameter no more than 12.2mm.

The CV joint assembly must not form an integral part of the drive shaft assembly.

9.7 Semi-automatic gear change system :

The ECU may be used as gearbox control unit. In case the ECU doesn't provide such functionality, it must be possible to add a standalone gearbox control unit without modifying or changing the chassis or gearbox loom.

Only electric or pneumatic semi-automatic shift systems are permitted.

The manufacturer responsible for the gearbox control unit must provide a mechanism that allows the scrutineers to accurately identify the software version loaded on the gearbox control unit.

9.8 Clutch disengagement:

All cars must be fitted with a means of disengaging the clutch for a minimum of fifteen minutes in the event of the car coming to rest with the Power Unit stopped.

This system must be in working order throughout the Event even if the main hydraulic, pneumatic or electrical systems on the car have failed.

The driver, when seated normally in the car with the seat belts unfastened, must be able to activate the system in less than five seconds.

The system must be designed in such a way that it can't be used to disengage or partially engage the clutch during the start procedure of a race.

ARTICLE 10 : SUSPENSION AND STEERING

10.1 General:

The suspension must be a double triangle wishbone configuration with a pushrod.

10.1.1 Front suspension

The front internal suspension must consist of only the following main elements; two rocker arms, two corner springs, two corner dampers, one anti-roll bar and one tri-spring.

The rocker arms must be directly actuated by the pushrods.

The dampers and corner springs must be directly actuated by the rocker arms. The anti-roll bar and tri-spring may be actuated by mechanical linkages.

The motion of each corner spring and corner damper must be a strictly monotonic relationship to the vertical wheel motion of one front wheel relative to the sprung mass.

The tri-spring motion must be a strictly monotonic relationship to the vertical wheel motion of both front wheels relative to the sprung mass. Either a constant rate coil spring or a stack of identical Belleville washers may be fitted. ~~With the car at its design ride height and at the weight of the complete car plus driver without fuel there must be at least 5mm free motion before these spring elements are contacted.~~ At legality checks, with the car supported on its wheels at loads exceeding the minimum values stipulated in Art. 4.1, the tri-spring shall retain no less than 5 mm of free travel prior to contact with any spring element.

The anti-roll bar must only have discrete dedicated adjustment positions. Continuously variable sliding adjustments are forbidden.

The rocker arm support, the dampers, the corner springs and the tri-spring must be situated on top of the survival cell.

10.1.2 Rear suspension

The rear internal suspension must consist of only the following main elements; two rocker arms, two corner springs, two corner dampers and one anti-roll bar. A tri-spring is not permitted.

The rocker arms must be directly actuated by the pushrods.

The dampers and corner springs must be directly actuated by the rocker arms. The anti-roll bar may be actuated by mechanical linkages.

The motion of each corner spring and corner damper must be a strictly monotonic relationship to the vertical wheel motion of one front wheel relative to the sprung mass.

The anti-roll bar must only have discrete dedicated adjustment positions. Continuously variable sliding adjustments are forbidden.

10.2 Chromium plating :

Chromium plating of any steel suspension components is forbidden.

10.3 Suspension members :

10.3.1 All suspension members must be made from a homogeneous metallic material.

10.3.2 In order to help prevent a wheel becoming separated in the event of all suspension members connecting it to the car failing, flexible tethers must be fitted. The sole purpose of the tethers is to prevent a wheel becoming separated from the car, they should perform no other function.

Each wheel must be fitted with two tethers.

Each tether:

- a) Must comply with FIA Standard 8864-2022 and be rated for a minimum 'energy absorbed' of 7kJ and a ~~'minimum vehicle pick up force' of 70kN~~ **vehicle pick up force not exceeding the value indicated at point b)**, as referred to in Technical List n°93.
- b) Must have its own separate attachments at both ends which:
 - i. Are able to withstand a tensile force of 70kN in any direction within a cone of 45° (included angle) measured from the load line of the relevant suspension member.
 - ii. On the survival cell or gearbox are separated by at least 100mm measured between the centres of the two attachment points.
 - iii. On each wheel/upright assembly are separated by at least 90° radially with respect to the axis of the wheel and 100mm measured between the centres of the two attachment points.
 - iv. Are able to accommodate a tether end fitting with a minimum inside diameter of 15mm.

Furthermore, no suspension member may contain more than one tether.

The manufacturer must supply detailed geometries which clearly show that all of the tethers will independently prevent a wheel from making contact with a driver's head during an accident, with the secondary roll structure fitted, assuming 40% elongation in each tether.

10.3.3 The overall cross-sections of each member of every suspension component (with any non-structural shroud for wheel tethers included) must have an aspect ratio no greater than 3.5:1 and be symmetrical about its major axis. All suspension components may however have sections with an aspect ratio greater than 3.5:1, and be non-symmetrical, provided these are adjacent to their inner and outer attachments and form no more than 25% of the total distance between the attachments of the relevant member.

All measurements will be made perpendicular to a line drawn between the inner and outer attachments of the relevant member.

10.3.4 No major axis of a cross section of a suspension member may subtend an angle greater than 5° to the reference plane when measured parallel to the car centre plane.

The major axis of a cross section of one wishbone arm must be parallel to the other one.

10.3.5 Shrouds and covers on any suspension member must be non-structural and will be permitted for the sole purpose of protecting wheel tethers and brake lines. Shrouds and covers may not be permanently attached to suspension members. It must therefore be possible to remove them without the use of tools.

10.3.6 Flexible joints of any kind are forbidden.

10.4 Suspension dampers:

10.4.1 Only conventional hydraulic, single tube dampers with one piston and maximum two-way adjustment are permitted in any position.

10.4.2 Damper fluid may be pressurised.

10.4.3 Damper characteristics may only vary as a function of damper piston speed, created only by suspension movement. Any other variation of damper characteristics, such as those which vary as a function of position, frequency or acceleration, are not permitted.

10.4.4 The use of blow-off valves, inertia valves, external electronic inputs, the storage of energy or any hydraulic connections between dampers are not permitted.

10.4.5 The use of any kind of bump stop is prohibited.

10.5 Sprung suspension :

Cars must be fitted with sprung suspension.

In order to avoid mass dampers, the suspension system must be so arranged that its response results only from changes in load applied to the wheels.

The springing medium must not consist solely of bolts located through flexible bushes or mountings.

There must be movement of the wheels to give suspension travel in excess of any flexibility in the attachments.

10.6 Springs:

Only conventional coil springs may be used.

10.7 Suspension uprights:

Only two types of upright may be used for all four wheels. For this Article, the upright is considered to be the main housing, holding the wheel bearing. Additional brackets may be attached to the upright.

The upright must be a solid part made from machined aluminium-based alloy or casting. Sheet metal is forbidden.

10.8 Wheel bearings:

Only one bearing per wheel is allowed (a bearing with one outer race / split inner races will be allowed).

10.9 Steering :

10.9.1 The steering must consist of a mechanical link between the driver and the front wheels.

10.9.2 Four wheel steering is not permitted.

10.9.3 The steering wheel, steering column and steering rack assembly must be subjected to an impact test. Details of this test procedure may be found in Article 16.5.

10.9.4 No part of the steering wheel or column, nor any part fitted to them, may be closer to the driver than a plane formed by the entire rear edge (closest to the driver) of the steering wheel rim. All parts fixed to the steering wheel must be fitted in such a way as to minimise the risk of injury in the event of a driver's helmet making contact with any part of the wheel assembly.

10.9.5 The torque gradient at the steering wheel for a specific static car condition must be shown by calculation to be no greater than 10 Nm/g and this must be the case for all front suspension and steering configurations available to the competitor. The calculation is to be with the car at the design ride heights with the steering wheel in the straight-ahead condition and should state the car weight, weight distribution, the ratio of front to rear lateral force on the tyres (based on weight distribution), the castor, the total trail and the steering ratio. The total trail is to be the sum of the mechanical trail (castor trail) plus 20mm pneumatic trail (constant value assumed for the purpose of this calculation). For the avoidance of doubt, this calculation is to determine a basic torque gradient for a car in a straight-ahead condition, not a cornering case. The

submission must include the specification of the parts used to determine the worst-case configuration, including the steering pinion, the steering arm length and the components that define the castor.

ARTICLE 11 : BRAKES

11.1 Separate circuits :

All cars must have a brake system which has at least two separate circuits operated by the same pedal. Each circuit must have its own brake fluid reservoir. This system must be designed so that if leakage or failure occurs in one circuit, the pedal shall still operate the brakes on at least two wheels.

11.2 Brake discs :

Brake discs must be made from ferrous material.

Brake discs must not be drilled. Additionally, all discs must be ventilated and have minimum thickness of 25.0mm when new.

The weight of a new brake disc must not be less than 2450g. The weight of a complete new brake disc assembly must not be less than 2900g.

Only one type of brake disc for all four wheels may be used. Brake discs that are symmetrical about the car centre plane (the parts itself, when installed on the car), are considered being the same type.

In order that each brake disc is readily identifiable by scrutineers, each one produced must be permanently marked with a unique number which is accessible for verification at any time.

11.3 Brake calipers :

All brake calipers must be made from aluminium materials with a modulus of elasticity no greater than 80Gpa.

There must be four brake caliper pistons on each wheel.

The weight of a brake caliper must not be less than 1200g.

Only two types of calipers per car are admitted. Brake caliper that are symmetrical about the car centre plane (the parts itself, when installed on the car), are considered being the same type.

Viewed from the side, no part of the brake calliper may lie between two lines at 60 degrees to each other, starting from the front wheel centre line at 60 degrees below a horizontal plane through the front wheel centre line.

Any type of floating calliper installation is forbidden.

The brake pad abutment must be perpendicular to the brake disc surface.

11.4 Liquid cooling :

Liquid cooling of any part of the braking system is forbidden.

11.5 Brake pressure modulation :

Anti-lock brakes and power braking are forbidden.

Furthermore, any device or construction the purpose and or effect of which is to provide non-linear brake system pressures (other than any inherent mechanical non-linearity) is forbidden.

The force normal to the brake pad must be solely a function of the brake pressure.

11.6 Brake pads

Only one type (design and geometry) of brake pad for all four wheels may be used.

A competitor may choose at maximum between three different types (compound of the brake pad friction material) of homologated brake pads.

For one championship, the total number of brake pads may be more than three. The brake pad types will be then split into groups of three each. A competitor has to choose one group for the complete season.

The brake pads available must be defined in the Sporting Regulations of each Championship.

11.7 Braking force

The ratio of brake pedal force to brake system pressure must be no greater than 7.5 N/bar for any configuration of brake system components available. The brake pedal force is applied at the centre of the brake pedal and the brake system pressure is the sum of the front and rear pressure of the two circuits. This must be shown by calculation for the worst-case brake configuration available.

ARTICLE 12 : WHEELS AND TYRES

Preamble :

The wheel attachment system should be designed such that the operation of the car is possible without using pneumatic wheel guns.

12.1 Location

Complete wheels must be external to the bodywork in plan view, with the rear aerodynamic device removed.

12.2 Wheel material

All wheels must be a single piece type, made from aluminium-based alloy.

12.3 Dimensions and weights

12.3.1 Tyre mounting width: Front 10" (254.0mm +/- 3mm)

Rear 12" (304.8mm +/- 3mm)

Nominal wheel bead diameter: 380.6mm

12.3.2 These measurements will be taken horizontally at axle height.

12.3.3 The weight of a front rim must not be less than 6500g.

The weight of a rear rim must not be less than 7000g.

12.4 Maximum number of wheels

The number of wheels is fixed at four.

12.5 Wheel retention

All cars, whilst under their own power, must be fitted with a device which will retain the wheel fastener in the event of it coming loose.

A safety spring must be in place on the wheel nut throughout the event and must be replaced after each wheel change. These springs must be painted fluorescent red or orange.

Alternatively, another method of retaining the wheels may be used, provided it has been approved by the FIA.

12.6 Pressure control valves

Pressure control valves on the wheels are forbidden.

12.7 Aerodynamic influence

Any device, construction or part of the wheel that is designed for the purpose of guiding or influencing the airflow through the wheel, or whose purpose is anything other than transferring load from the tyre to the wheel hub, is forbidden.

12.8 Tyre specification

Tyre specifications will be determined by the FIA appointed tyre supplier, in agreement with the FIA.

The specification of the tyres will not be changed without the agreement of the FIA, the FIA may decide to change the specification during the Championship season for safety reasons without notice or delay.

12.9 Treatment of tyres

a. Tyres may only be inflated with air or nitrogen.

b. Any process the intent of which is to reduce the amount of moisture in the tyre and/or in its inflation gas is forbidden.

c. A **Complete Wheel** must contain a single fixed internal gas volume. No valves, bleeds or permeable membranes are permitted other than to inflate or deflate the tyre whilst the car is stationary.

Any device, system or procedure (except for driving of the car) the purpose and/or effect of which is to heat the wheels, hubs or brakes above the ambient air temperature, or to maintain their temperature if they are already warm, is prohibited.

ARTICLE 13 : COCKPIT

13.1 Accommodating different driver sizes

The cockpit and all parts of the cockpit installation such as pedals, seat and steering wheel must be designed in a way that drivers with a spread of body size from 1.50m up to 1.97m may be fitted in the car while respecting the seating position requirements.

The driver installation adjustment has to be approved by the FIA Single Seater Department during the homologation process. The adjustment of the pedals must be possible without using additional adapter plates or similar.

The compliance with the above mentioned requirements have to be demonstrated during the homologation process by fitting the different human CAD models (three different sizes: small, medium and large), provided by the FIA, in the car. Detailed fitting instructions can be found in the Appendix to the Technical Regulations.

In order to achieve a limitation of the seat foam inserts thickness of 50mm, different sizes of extractable seats as defined in Article 14.7 must be used to fit the human CAD models. Additional gap fillers must be used to fill the voids between the extractable seat and the survival cell created by different sizes of seats. Those gap fillers must comply with the requirements which can be found the Appendix to the Technical Regulations.

13.2 Entry and Exit

The driver must be able to enter and get out of the cockpit without it being necessary to open a door or remove any part of the car other than the steering wheel. From his normal seating position, with all seat belts fastened and whilst wearing his usual driving equipment, the driver must be able to remove the steering wheel and get out of the car within 7 seconds and then replace the steering wheel in a total of 12 seconds.

For this test, the position of the steered wheels will be determined by the FIA Technical Delegate and after the steering wheel has been replaced steering control must be maintained.

13.3 Helmet Position

When seated normally, the driver must be facing forwards and the rearmost part of his crash helmet must be between XC= -50 and XC= -125. The driver's helmet must lie below a line drawn between the front fixing axis of the secondary roll structure and a point 75mm vertically below the highest point of the principal roll structure.

13.3 Steering wheel

The steering wheel must be fitted with a quick release mechanism. Its method of release must be by pulling a concentric flange installed on the steering column behind the wheel.

The steering wheel, at any rotation, must lie below a line drawn between the front fixing axis of the secondary roll structure and a point 75mm vertically below the highest point of the principal roll structure.

The steering wheel must be positioned such that at any angle of rotation there is at least 50mm between any part of the steering wheel assembly rearward of the collapsible steering column element and the survival cell and bodywork, when measured parallel to the steering wheel axis.

13.4 Internal cross section:

13.4.1 A free vertical cross section, which allows the outer template shown in Drawing 3 to be passed vertically through the cockpit to a point 100mm behind the face of the rearmost pedal when in the inoperative position, must be maintained over its entire length.

The only things which may encroach on this area are the steering wheel and any padding that is required by Article 14.6.5.

13.4.2 A free vertical cross section, which allows the inner template shown in Drawing 3 to be passed vertically through the cockpit to a point 100mm behind the face of rearmost pedal when in the inoperative position, must be maintained over its entire length.

The only thing which may encroach on this area is the steering wheel.

13.5 Position of the driver's feet

The face of the foremost pedal, when in the inoperative position, must be situated no less than 250mm rearward of A-A and rearward of the front wheel centre line.

13.6 Clutch, brake and throttle pedal

The clutch, brake and throttle pedal may only be operated by the driver's foot. Any device or construction that is designed to influence the clutch or brake pressure or the throttle opening by any other means is forbidden.

The only exception to the above are homologated functionalities provided by the ECU.

ARTICLE 14 : SAFETY EQUIPMENT

14.1 Fire extinguishers

All cars must be fitted with a Plumbed-in Fire Suppression System for Open Cockpit Cars which shall discharge simultaneously into the survival cell, the sidepods and into the engine compartment. The Plumbed-in Fire Suppression System for Open Cockpit Cars system must be approved according to the FIA Standard 8876-2022.

The system must be used in accordance with the manufacturer's instructions and with Technical List n°[97].

Any triggering system having its own source of energy is permitted, provided it is possible to operate all extinguishers should the main electrical circuits of the car fail.

The driver must be able to trigger the extinguishing system manually when seated normally with his safety belts fastened and the steering wheel in place.

Furthermore, a means of triggering from the outside must be combined with the circuit breaker switches described in Article 14.2.2. They must be marked with a letter "E" in red at least 80mm tall, with a line thickness of at least 8mm, inside a white circle of at least 100mm diameter with a red edge with a line thickness of at least 4mm.

14.2 Master switch

14.2.1 The driver, when seated normally with safety belt fastened and steering wheel in place, must be able to cut off all electrical circuits to the ignition, all fuel pumps and the rear light by means of a spark proof circuit breaker switch. It must also shutdown the ERS system.

This switch must be located on the dashboard and must be clearly marked by a symbol showing a red spark in a white edged blue triangle.

14.2.2 There must also be two exterior horizontal handles which are capable of being operated from a distance by a hook. These handles must be situated at the base of the principal roll structure on both sides of the car and have the same function as the switch described in Article 14.2.1.

14.3 Rear view mirrors

14.3.1 All cars must have at least two mirrors mounted so that the driver has visibility to the rear and both sides of the car.

14.3.2 The reflective surface of each mirror must be at least 150mm wide, this being maintained over a height of at least 50mm. Additionally, each corner may have a radius no greater than 10mm.

14.3.3 No part of the mirror reflective surface may be less than 250mm from the car centre plane, less than 550mm forward or more than 750mm forward of the plane C-C.

No part of the rear view mirrors, the mirror housings or the mirror mountings may be situated more than 500mm from the car centre plane.

The rear view mirror supports must have an aspect ratio no greater than 3.5 to 1.

14.3.4 The scrutineers must be satisfied by a practical demonstration that the driver, when seated normally, can clearly define following vehicles.

For this purpose, the driver shall be required to identify any letter or number, 150mm high and 100mm wide, placed anywhere on boards behind the car, the positions of which are detailed below :

- Height : From 400mm to 1000mm from the ground.
- Width : 2000mm either side of the car centre plane.
- Position : 10m behind the rear axle line of the car.

14.4 Safety belts

The wearing of two shoulder straps, one abdominal strap and two straps between the legs is mandatory. These straps must be securely fixed to the car and must comply with FIA standard 8853-2016.

Detailed calculations have to be provided, showing that the safety belt anchorage points are able to withstand 15kN in any accident direction. Detailed requirements of the calculations can be found in the Appendix to the Technical Regulations.

14.5 Rear light

All cars must have three rear lights in working order throughout the event which:

- a. Is a model approved according to FIA standard 8874-2019 and approved by the FIA for F3/F4 cars.
- b. Are clearly visible from the rear.
- c. Can be switched on by the driver when seated normally in the car.

The first such light must:

- d. Faces rearwards at 90° to the car centre plane and the reference plane.
- e. Not be mounted more than 100mm from the car centre plane.
- f. Be at least 280mm above the reference plane.
- g. Be no less than 450mm behind the rear wheel centre line, measured to the face of the lens and parallel to the reference plane.

The measurements being taken to the centre of area of the lens.

Additionally, two further lights must be fitted, one on each side of the car. Each such light must:

- h. Lie in its entirety between 700mm and 850mm above the reference plane.
- i. Lie in its entirety at least 520mm from the car centre plane.
- j. Lie in its entirety at least 650mm behind the rear wheel centre line.
- k. In side view, be covered completely by the rear wing endplates defined in Article 3.6.3
- l. Respect the directionality of the lens of the LED elements, which should point at a nominally horizontal direction towards the back.
- m. Ensure electrical redundancy from the first light by using an independent, isolated power supply.

All three lights should flash with a minimum 40% duty cycle at a rate of

- 10 Hz when the engine is stalled
- 4 Hz when used as a rain light
- 1 Hz when any kind of speed limiter or VSC/FCY is activated

14.6 Cockpit padding

14.6.1 All cars must be equipped with the following areas of padding for the driver's head which:

- a. Are so arranged that they can be removed from the car as a single part.
- b. Are made from a material which is corresponding to the specification: CONFOR CF45 (Blue) or CONFOR CF45M (Blue) (FIA Technical List n°17)
- c. In all areas that are not in contact with the chassis, the padding must be covered with two plies of Aramid fibre/epoxy resin composite pre-preg material in plain weave, consisting of one 60gsm fabric and one 170gsm fabric, with a cured resin content of 50% ($\pm 5\%$) by weight.
- d. Are positioned to be the first point of contact for the driver's helmet in the event of an impact projecting the helmet towards the padding.
- e. Must be so installed that if movement of the driver's head, in any expected trajectory during an accident, were to compress the padding fully at any point, his helmet would not make contact with any structural part of the car.
- f. Do not obscure sight of any part of the driver's helmet when he is seated normally and viewed from directly above the car.

Any void between each of these areas of padding must also be completely filled with the same material.

The cockpit padding must enclose RV-HEADREST-TMP.

14.6.2 The rear area of padding must be positioned behind his helmet and be between 75mm and 90mm thick over an area of at least 65000mm².

The bottom surface must be in contact with survival cell to avoid any vertical movement.

If necessary, and only for driver comfort, an additional piece of padding no greater than 10mm thick may be attached to this headrest provided it is made from the same material.

14.6.3 Whilst normally seated, two side areas of padding must be installed each side of the driver. The padding must extend from the rear area of padding up to 400mm forward of C-C.

The padding must be no less than 95mm thick, this minimum thickness being maintained to the upper edges of the survival cell and over the entire length of the padding. The minimum thickness will be assessed perpendicular to the car centre plane but a radius no greater than 10mm may be applied along their upper inboard edges.

If necessary, and only for driver comfort, an additional piece of padding no greater than 20mm thick may be attached to this headrest provided it is made from the same material which incorporates a low friction surface.

14.6.4 Further cockpit padding must be provided on each side of the cockpit rim from the side areas of padding up to minimum 675mm forward of C-C. The purpose of the additional padding is to provide protection to the driver's head in the event of an oblique frontal impact and must, therefore, be made from the same material as the other three areas of padding.

These extensions must:

- a. Be symmetrically positioned about the car centre plane and a continuation of the side areas of padding.
- b. Be positioned with their upper surfaces at least as high as the survival cell over their entire length.
- c. Have a radius on their upper inboard edge no greater than 10mm.

14.6.5 Fixings

The Headrest should be fixed in a way that is clearly indicated and should be easily removable without tools. Fixings should consist of:

- a. Two cylindrical longitudinal pegs with a diameter of at least 6mm and with an engagement of at least 12mm into the rear of the cockpit opening
- b. A keyhole fixing at $X_c = 250 \pm 50$ mm and $Z = 610 \pm 25$ mm on each side of the car. These fixings must prevent the headrest from moving laterally or vertically with up to 12 mm of forward movement of the headrest and the receptacle mounted on the survival cell must be flush with the survival cell structure.
- c. A quick release fixing which is clearly indicated at the front corner on each side of the car. No tape or similar material may be used to cover the forward fixings of the headrest. Furthermore, for the benefit of rescue crews the method of removal must also be clearly indicated.

14.6.6 In order to minimise the risk of leg injury during an accident, additional areas of padding must be fitted each side of, and above, the driver's legs.

These areas of padding must:

- a. Are made from a material which is corresponding to the specification: CONFOR CF45 (Blue) or CONFOR CF45M (Blue) (FIA Technical List n°17)
- b. Be covered with non-flammable and non-combustible material.
- c. Be no less than 25mm thick over their entire area.
- d. Cover the area situated between the plane B-B and 100mm behind the face of the rearmost pedal when in the inoperative position.
- e. Cover the area above the line A-A shown in Drawing 3.

14.7 Seat, seat fixing and removal

14.7.1 In order that an injured driver may be removed from the car in his seat following an accident, all cars must be fitted with a seat complying with the FIA Specification for Extractable Seats in Open Cockpit Cars. The use of bolts to secure the seat is forbidden.

14.7.2 The seat shall be firmly retained longitudinally and laterally with no more than four pins. The pins must engage the Extractable Seat in its operational position by a minimum of 10mm measured along their axis.

14.7.3 The seat must be equipped with receptacles which permit the fitting of belts to secure the driver and one which will permit the fitting of a head stabilisation device. The receptacles must be easily accessible to rescue crews.

14.7.4 The seat must be removable along the direction normal to the reference plane without the need to cut or remove any of the seat belts.

A test must be carried out on the seat when fitted to a fully representative car with the driver present. Once the buckle has been released it must be possible to extract the seat from the car without any further adjustment of the harness.

14.7.5 Any seat made from foam must be covered with a non-flammable and non-combustible material. The cladding materials shall be tested for flammability in accordance with ISO standard 3795. The speed of combustion shall be less than or equal to 75 mm/min. The thickness of any foam insert is limited to maximum 50mm.

The foam thickness is measured the following:

- Behind and underneath the driver parallel to the car centre plane
- Beside the driver normal to the car centre plane

14.7.6 To ensure compatibility with the seat gap fillers referred to in Article 13.1, the top edge of the pelvis side supports and the forward edge of the shoulder side supports (if present) must be able to deflect outward in the lateral direction by at least 30mm without creating sharp edges.

14.8 Head and neck supports

No head and neck support worn by the driver may be less 25mm from any structural part of the car when he is seated in his normal driving position.

14.9 Towing device

Each car must be equipped at the rear with a sturdy towing device which must be marked in fluorescent red.

ARTICLE 15: CAR CONSTRUCTION

15.1 Materials used for car construction

15.1.1 The use of ceramic materials is forbidden other than for brake pad friction materials. Ceramic Materials (e.g. Al_2O_3 , SiC, B_4C , Ti_5Si_3 , SiO_2 , Si_3N_4) – These are inorganic, non metallic solids.

The use of titanium materials in safety belts complying with FIA standard 8853-2016 is allowed.

The use of titanium materials for the principal roll structure, suspension members and the front fixation of the secondary roll structure is forbidden.

The use of titanium materials in any other case has to be approved for each part separately by the FIA during the homologation process.

15.1.2 Any repairs to the survival cell or nosebox must be carried out in accordance with the manufacturer's specifications, in a repair facility approved by the manufacturer.

15.1.3 The car may not be used in another event until the technical passport has been completed satisfactorily.

15.1.4 In exception to the above, ERS materials are free.

15.2 Roll structures

15.2.1 All cars must have two roll structures which are designed to help prevent injury to the driver in the event of the car becoming inverted.

The principal structure must be designed such that in top and side view no part of the surface **RS-Roll-Struct** is visible with exception of the opening defined in Article 15.2.6. No part of the principal roll over structure may protrude through the surface **RS-Roll-Struct-Lim**.

Above $Z=920\text{mm}$, the principal structure must have an external surface that is visible from above, which is tangent continuous and does not contain any concave radius of curvature. Any convex radius of curvature must be no smaller than 10 mm. Minimal local deviations from this surface are permitted where the load pad described in Article 17.2 contacts the structure and for the mounting of a camera.

The secondary roll structure, which is not considered part of the survival cell, must be positioned symmetrically about the car centre plane with its front fixing axis 1000mm forward of the plane C-C and 650mm above the reference plane. The mounting faces for the rearward fixings must lie on a plane parallel to and 685mm above the reference plane.

Referring to Drawing 5, the driver's helmet and steering wheel must be arranged such that they lie below the following two lines:

- a line drawn between the front fixing axis of the secondary roll structure and a point 75mm vertically below the highest point of the principal roll structure.
- a line, tangent to the highest point of the secondary roll structure at an angle of 4.0° to the reference plane.

15.2.2 The principal roll structure may not form an integral part of the survival cell, must be made from a homogeneous metallic material and must be fixed through a bolted connection to the survival cell. The attachment of the principal roll structure to the survival cell may not fulfil any other function or purpose whatsoever.

The principal structure must pass two static load test details of which may be found in Article 17.2.

In addition, detailed calculations have to be provided, showing that the principal roll structure and survival cell are able to sustain the following loads:

1. a load of 150 kN vertically downwards, applied to the highest and most forward point of the principal roll structure through a rigid element representing a flat pad which is 200 mm in diameter and perpendicular to the loading axis.
2. a load of 123 kN applied in lateral direction and acting through and about the highest and most forward point of the principal roll structure.

Detailed requirements of the calculations can be found in the Appendix to the Technical Regulations.

- 15.2.3** The Secondary Roll Structure attachments to the survival cell must pass four static load tests details of which may be found in Article 17.3.
- 15.2.4** The Secondary Roll Structure must comply with the FIA standard 8869-2018 Part 2 (Steel), approved structures are listed in Technical List n°62. The Secondary Roll Structure shall be installed in accordance with the manufacturer's instruction.
- 15.2.5** In order that a car may be lifted quickly in the event of it stopping on the circuit, the principal rollover structure must incorporate a clearly visible unobstructed opening designed to permit a strap, whose section measures 60mm x 30mm, to pass through it.

15.3 Structure behind the driver

The parts of the survival cell or the structural support (as mentioned below) immediately behind the driver which lie less than 150mm from the car centre plane, must be situated no further forward than the line a-a1-b-c-d-e shown in Drawing 2.

The parts of the survival cell or the structural support (as mentioned below) immediately behind the driver which lie less than 150mm from the car centre plane and between 80mm and 460mm above the reference plane, may not be situated more than 20 mm rearward of the line a-a1-b-c shown in Drawing 2, the 20mm measured normal to the relevant sections of the line a-a1-b-c.

No part of the survival cell or the seat shell may be within a volume defined by a spherical object of 250mm diameter and with its centre point on the car centre plane, 595mm above the reference plane and 145mm forward of the plane C-C.

The survival cell must provide structural support for the driver's seat in an area less than 150mm from car centre plane and between 80mm and 460mm above the reference.

The support is not required to form an integral part of the survival cell.

If an ES should be installed inside the survival cell, it must be fitted on the floor behind the driver's seat. The volume for the ES must be isolated from the cockpit.

In order to validate the integrity of this structure the survival cell must pass an impact test against a solid vertical barrier placed parallel to C-C. Details of the test procedure may be found in Article 16.3.

The survival cell and structural support for the driver's seat must pass static load test. Details of the test procedure may be found in Article 18.10.

15.4 Survival cell specifications

15.4.1 Identification Transponders

Every survival cell must incorporate three FIA supplied transponders for identification purposes. These transponders must be a permanent part of the survival cell, be positioned in accordance with Drawing 7 and must be accessible for verification at any time.

15.4.2 Cockpit opening

In order to ensure that the opening giving access to the cockpit is of adequate size, the template shown in Drawing 2 will be inserted into the survival cell and bodywork.

During this test the secondary roll structure, steering wheel, steering column, seat and all padding required by Articles 14.6 (including fixings), may be removed and the template must be held horizontal so its lower face is parallel to the reference plane and lowered vertically from above the car until its lower face is 535mm above the reference plane.

Referring to Drawing 2, the rear edge of the template must be on the plane C-C.

When the test described above is carried out and the template is in position with its lower face parallel to and 535mm above the reference plane, the shape of the survival cell must be such that no part of it is visible when viewed from either side of the car. The parts of the survival cell which are situated each side of the driver's head must be no more than 550mm apart.

15.4.3 Openings in the Survival Cell

The survival cell must have an opening for the driver, the minimum dimensions of which are given in Article 15.4.2. Any other ducts or openings in the survival cell must either:

- a) Be of the minimum size, and for the sole purpose of allowing access to mechanical components.
- b) Minimal openings for the sole purpose of mounting specific components, including suspension brackets, timing transponders, antennae, medical light and clutch disengagement button.
- c) Be for the sole purpose of cooling the driver or mechanical or electrical components, the area of any such duct or opening may not exceed 3000mm².
- d) Be for the sole purpose of routing wiring looms, cables or fluid lines, the total combined area of any such openings must not exceed 7000mm².
- e) The survival cell front bulkhead, before the application of the panel defined in Article 15.5.4, may have an opening no greater than 25000mm².

15.4.4 Standard planes

- a. A A: the plane $XA=0$
- b. C C: a plane, at $XA \geq 1900$
- c. B B: the plane $XC = - 875$
- d. The Front Wheel Centre line must be between 1650 mm and 1800 mm forward of C-C.
- e. The plane XPU must be at least 180mm rearward of C-C.

15.4.5 Survival Cell Dimensions

Before the openings allowed in Articles 15.4.2 and 15.4.3 are created, a single volume, which is symmetrical about $Y=0$, continuous, and has no apertures must be defined in accordance with the conditions laid out below. For this purpose, the panels specified in 15.5.2 and 15.5.3 are considered part of the survival cell.

- a. The external width of the survival cell between the planes B-B and C-C must be no less than 480mm and must be at least 75mm per side wider than the cockpit opening when measured normal to the inside of the cockpit aperture. These minimum dimensions must be maintained over a continuous height of at least 350mm.

- b. Between the planes A-A and B-B, any external cross-section of the survival cell by a plane parallel to C-C must contain a rectangle with radii applied on its bottom corners and chamfers applied on its top corners, positioned symmetrically about the car centre plane, of the following dimensions:
 - i. width defined by a linear interpolation from 480mm at the plane B-B to 355mm at the plane A-A
 - ii. height defined by a continuous (non-linear) decrease from 400mm at the plane B-B to 300mm at the plane A-A
 - iii. bottom corner and top chamfer by a linear interpolation between the two cross sections at plane B-B and plane A-A as defined in Drawing 4.
- c. The survival cell must contain the surface RS-SC-LWR.
- d. Referring to Drawing 8, the survival cell must provide a minimum free pedal volume from the front wheel centre line to 400mm behind the front wheel centre line. No part of the survival cell may encroach in the volume, which is defined by a linear extrusion of the above sections parallel to the car centre plane and at an angle of maximum $\pm 10^\circ$ to the reference plane.
- e. No part of the survival cell may encroach in RV-BB-TMP. The local planes $X_{RV-BB-TMP}$ and $Y_{RV-BB-TMP}$ defined in RV-BB-TMP must lie on $X_B=0$ and $Y=0$.

15.4.6 Behind the driver, the survival cell must contain the surface **RV-SC-Tower**.

15.4.7 Power Unit fixations

All Power Unit fixation points on the survival cell as shown in Drawing 1 must lie on X_{PU} . A tolerance of 2 mm in X-direction (along the car centre plane) is permitted for manufacturing tolerances and the use of steel bushes.

15.5 Intrusion Protection

In order to protect the driver and the fuel cell in case of an impact, the sides and lower surfaces of the survival cell must comply with the following requirements.

For the purpose of the following requirement, a laminate is considered not uniform in an area where more than 20% of the number skins are interrupted within 50mm (taking the higher number of skins in the area in question as reference, mathematically rounded to closest integer).

15.5.1 Sidewall Laminate

The sides and lower surfaces of the survival cell should be constructed to a laminate that has the ability to pass a strength test. Details of the test procedure may be found in Article 18.7.1.

This laminate should extend in a longitudinal sense from A-A to the rear of the survival cell.

The laminate should cover:

- a. From $X_A=0$ to $X_C=-1500$, all surfaces which, in side view, lie below $Z=425$, and above $Z=100$.
- b. From $X_C=-1500$ to $X_C=-1000$, all surfaces which, in side view, lie below a straight line between $[X_C, Z] = [-1500, 425]$ and $[X_C, Z] = [-1000, 550]$, and above $Z=100$.
- c. From $X_C=-1000$ to the rear of the survival cell, all surfaces below $Z=550$ and above $Z=100$.

Additional plies may be added to this laminate. The core thickness or density may be increased or the core may be replaced with solid inserts.

Minimal Recesses are permitted for the sole purpose of mounting specified components, including but not limited to: suspension brackets, suspension fairings, sensors, and stays.

In all cases, the FIA technical delegate must be satisfied that the overall strength of the structure has been improved by doing so and that its ability to pass the test given by “Side Panel Test Procedure 01/21”.

15.5.2 Main Sidewall Laminate

All surfaces more than 140mm from Y=0 which, in side view, lie between B-B, two lines at Z=100mm and Z=550mm and a curve that is offset 50mm rearward to the rearmost intersection of RS-FWD-FUEL-LIMIT with Y=0 between the two horizontal lines, must alternatively:

- i. have two panels permanently attached to each side of the underlying survival cell laminate described in Art. 15.5.1 with an appropriate adhesive which has been applied over their entire surface. Those two panels should be constructed to a uniform laminate that has the ability to pass a strength test. Details of the test procedure may be found in Article 18.7.2.

A 50mm linear taper may be included at the forward and rearward boundaries of the panel, and a 20mm linear taper may be included at the upper boundary of the panel behind XC=375. The taper dimensions are measured normal to the boundaries.

Cut-outs in this panel totalling 15000mm² per side will be permitted for fitting around the survival cell openings described in Article 15.4.2c) and essential fixings.

- ii. be constructed to a uniform laminate that has the ability to pass a strength test. Details of the test procedure may be found in Article 18.7.4. However, additional plies may be used, core thickness may be increased and the core may be replaced by an insert where applicable, and local relief applied, provided the FIA technical delegate is satisfied in each case that the overall strength of the structure has been improved by doing so. Modification to the uniform laminate of this panel for essential fixings, including openings described in Article 15.4.2c), must be limited to 15000mm² per side of the survival cell.

15.5.3 Forward Sidewall Laminate

The surfaces

- a. From XA=0 to XC=-1500, all surfaces which, in side view, lie below Z=425, and above Z=100.
- b. From XC=-1500 to XC=-1000, all surfaces which, in side view, lie below a straight line between [XC, Z] = [-1500, 425] and [XC, Z] = [-1000, 550], and above Z=100.
- c. From XC=-1000 to the rear of the survival cell, all surfaces below Z=550 and above Z=100 and that are not covered by the panel defined by Article 15.5.2.i.

must alternatively:

- i. have panels permanently attached to the underlying survival cell laminate described in Art. 15.5.1 with an appropriate adhesive which has been applied over their entire surface. Those panels should be constructed to a uniform laminate that has the ability to pass a strength test. Details of the test procedure may be found in Article 18.7.3.

A 25mm horizontal linear taper may be included at the forward and rearward boundaries of the panel. If made in more than one part, all adjacent panels must overlap by a minimum of 25mm. All overlaps may include linear tapers in the thickness of both overlapping parts.

This panel must overlap the panel defined by Article 15.5.2.i along all joining edges by a minimum of 25mm. If made in more than one part, all adjacent panels must overlap by a minimum of 25mm. All overlaps may include linear tapers in the thickness of both overlapping parts.

Cut-outs in this panel totalling 15000mm² per side will be permitted for fitting around the survival cell openings described in Article 15.4.2.c) and essential fixings.

- ii. be constructed to a uniform laminate that has the ability to pass a strength test. Details of the test procedure may be found in Article 18.7.5. However, additional plies may be used, core thickness may be increased and the core may be replaced by an insert where applicable, and local relief applied, provided the FIA technical delegate is satisfied in each case that the overall strength of the structure has been improved by doing so.

Modification to the uniform laminate of this panel for essential fixings, including openings described in Article 15.4.2c), must be limited to 15000mm² per side of the survival cell.

The Main Integrated Panel Area and Forward Integrated Panel Area as well as the transition between the two areas must be designed and manufactured as one continuous layup without junction. Junctions are only allowed in an area less than 125mm from the car centre plane.

15.5.4 Frontal Intrusion

A forward anti intrusion device, made from a homogeneous metallic material, must be fitted on the forward surface of the survival cell and must be solidly attached to it. The purpose of these structures is ensuring that the rear impact structure of a car ahead could not enter the survival cell through the front bulkhead if the Front Impact Structure were not present.

The panel must cover the entire surface of the survival cell front bulkhead. Cut-outs in this panel will be permitted up to 4000mm² measured when the panel is installed.

In order to ensure this is the case, a strength tests must be carried out successfully. Details of the test procedure may be found in Articles 18.9.

15.6 Survival cell safety requirements

15.6.1 The frontal impact absorbing structure must pass an impact test against a solid vertical barrier placed parallel to C-C. Details of the test procedure may be found in Article 16.2.

15.6.2 An impact absorbing structure must be fitted behind the gearbox symmetrically about the car centre plane with its rearmost point at least 680mm behind the rear wheel centre line.

The rearmost face of the impact structure must be a rectangular section no less than 100mm wide, this minimum width must be maintained over a height of at least 130mm and each corner may incorporate a radius no greater than 10mm.

The rearmost face of the impact structure may be no more than 360mm and no less than 170mm above the reference plane.

Except for fixation, the external cross section, in horizontal projection, forward of the rearmost face of the impact structure may not diminish.

The structure which was subjected to the three tests described in Article 18.8 must pass an impact test and be constructed from materials which will not be substantially affected by the temperatures it is likely to be subjected to during use. Details of this test procedure may be found in Article 16.4.

The rear impact absorbing structure should be attached to the gearbox case with a tether. This tether must serve exclusively to prevent the separation of the structure from the remainder of the car.

The tether must comply with FIA Standard 8864-2022 and be rated for a minimum 'energy absorbed' of 3kJ and a 'minimum vehicle pick-up force' of at least 30kN, as referred to in Technical List n°93.

The tether must have its own separate attachments at both ends which:

- a) Are able to withstand a tensile force equal to the 'minimum vehicle pick-up force' rating of the selected tether, in any direction within a cone of 45° (included angle) measured from the load line.
- b) Could be shared on gearbox side with the wheel tether attachment required by Article 10.4
- c) Are lying on either side of the expected point of failure. The chassis manufacturer must demonstrate by calculation and / or a physical test that the attachment points are different sides of the expected point of failure when applying a lateral load to the most rearward point of the rear impact absorbing structure.
- d) Are able to accommodate a tether end fitting with a minimum inside diameter of 15mm. The tether must utilise end fittings which result in a tether bend radius greater than 7.5mm.

15.6.3 The survival cell must also be subjected to four separate static load tests:

- 1) Survival cell side strength test.
- 2) Cockpit rim test.
- 3) Cockpit floor test.
- 4) Fuel tank floor test.
- 5) Suspension pick-up static test

Details of the test procedures may be found in Article 18.2, 18.3, 18.4, 18.5 and 18.6.

15.6.4 To test the attachments of the frontal and rear impact absorbing structures static side load tests must be carried out. Details of these test procedures may be found in Articles 18.7 and 18.8.

15.6.5 An impact absorbing structure must be fitted in front of the survival cell. This structure need not to be an integral part of the survival cell but must be solidly attached to it and be arranged symmetrically about the car centre plane.

The forward-most point of this structure must not be less than 950mm forward of the plane A-A.

The plane D-D is defined as a plane parallel to the plane C-C and 50mm rearward of the forward-most point of this impact absorbing structure.

The plane E-E is defined as a plane parallel to the plane C-C and 150mm rearward of the forward-most point of this impact absorbing structure.

This structure must have:

- a) A single external vertical cross-section at the plane D-D. The area of the part of this section that lies less than 100mm from Y=0 must exceed 9000mm².
No part of this cross-section may lie more than 200mm above the reference plane.
- b) A single external vertical cross-section whose area exceeds 20000mm² at the plane E-E.

Each external X-plane cross-section between E-E and XA=0 must be a single section with an area which exceeds a value given by a linear taper from 20000mm² to 105000mm² respectively. The only exception that may be made is for its attachment to the survival cell.

The first 150 mm behind its forwardmost point must be exchangeable and/or repairable without exchanging the complete impact-absorbing structure.

- 15.6.6** In order that every frontal and rear impact absorbing structure is readily identifiable by scrutineers, each one produced must incorporate one permanently embedded FIA approved transponders which are accessible for verification at any time.

ARTICLE 16: IMPACT TESTING

16.1 Conditions applicable to all impact tests

- 16.1.1 All tests must be carried out in accordance with FIA Test Procedure 01/00, in the presence of an FIA Technical Delegate and by using measuring equipment which has been calibrated to the satisfaction of the FIA Technical Delegate. A copy of the test procedure may be found in the Appendix to the Technical Regulations.
- 16.1.2 Any significant modification introduced into any of the structures tested shall require that part to pass a further test.
- 16.1.3 The test defined in the Article 16.3 must be carried out on the survival cell which has been subjected to the tests described in Articles 17.2, 17.3, 18.2, 18.3, 18.4, 18.5, 18.6 and 18.10.

16.2 Frontal test 1

To simulate in-car conditions, all parts which could materially affect the outcome of the test (including the Frontal Anti-Intrusion panel as defined in Article 15.5.4) must be fitted to the test structure which must be solidly fixed to the trolley through the mounting points of the nose structure, but not in such a way as to increase its impact resistance.

If the test facility includes a system to manage excess residual energy (in the event that the nose structure fails to absorb all the test energy), such a system must not in any way modify the results during a successful test.

For the purposes of this test, the total weight of the trolley and test structure shall be 750kg (+1%/-0) and the velocity of impact 17 metres/second.

The resistance of the test structure must be such that during the impact :

- a) The deceleration profile measured in g from the first deformation of the complete assembly does not exceed the limit curve defined by $10.9/X$, where X = the longitudinal distance from A-A calculated by the test laboratory in metres.
- b) Exceptionally, when filtered with a CFC60 filter (ISO 6487), the limit curve may be exceeded for a maximum cumulative period of 15ms and an absolute ceiling of 20g.
- c) The average deceleration over the first 150mm of deformation of the impact absorbing structure defined in Article 15.6.5 exceeds 2.5g.
- d) The peak deceleration of the trolley does not exceed 40g.

Furthermore, there must be no damage to the mountings of the nose.

This test must be carried out on a frontal impact absorbing structure which was subjected to the test described in Article 18.7.

16.3 Survival Cell Impact

The survival cell shall be subjected to an impact test defined by the Test Procedure 02/21.

All parts which could materially affect the outcome of the test must be fitted to the survival cell:

- Any Energy Storage(s) which is installed within or attached to the survival cell shall be fitted if:
 - the mass is greater than 2kg or,
 - the maximum stored energy is greater than 2000 kJ.
 - the electric energy storages (high and low voltage) can be replaced by a dummy unit having the same mass, dimensions and fixations.

- Any liquid fuel tank fitted shall be sealed and full of water.
- The cockpit padding (headrest) must be installed.
- The fire extinguisher(s) must be fitted and pressurised.

The dummy must be positioned in the extractable seat (if required by the relevant Technical Regulations) and the safety belts fastened. However, with the safety belts unfastened, the dummy must be able to move forwards freely in the cockpit.

The dummy shall be equipped with a helmet to FIA8860 or FIA8859 and an FHR to FIA8858 (the mass of the helmet and FHR should be recorded, but should not be included in the 75.5kg). The safety belts shall be fastened and tightened to represent in race conditions.

The secondary roll structure should not be installed.

For the purposes of this test, the velocity of impact shall not be less than 15 metres/second.

The impact wall must be fitted with crush tubes which develop a combined nominal load of 375kN and a nominal deceleration of 52g.

The resistance of the survival cell must be such that following the impact there is no structural damage to the survival cell, to the mountings of the safety belts, the fire extinguishers, the Fuel tank and/or the Energy Storage and the extractable seat (if present). The cockpit padding shall be still engaged in its design position.

16.4 Rear test

All parts which will be fitted behind the rear face of the Power Unit and which could materially affect the outcome of the test must be fitted to the test structure. If suspension members are to be mounted on the structure they must be fitted for the test. The structure and the gearbox must be solidly fixed to the ground and a solid object, having a mass of 750kg (+1%/-0) and travelling at a velocity of not less than 11 metres/second, will be projected into it.

The object used for this test must be flat, measure 450mm (+/-3mm) wide by 550mm (+/-3mm) high and may have a 10mm radius on all edges. Its lower edge must be at the same level as the car reference plane (+/-3mm) and must be so arranged to strike the structure vertically and parallel to the plane C-C.

During the test, the striking object may not pivot in any axis and the crash structure may be supported in any way provided this does not increase the impact resistance of the parts being tested.

The resistance of the test structure must be such that during the impact:

- a) The deceleration profile measured in g does not exceed the limit curve defined by $6.8/X$, where X = the longitudinal distance from RWCL calculated by the test laboratory in metres.
- b) The maximum deceleration does not exceed 30g.
- c) For $X > 0.225\text{m}$, the maximum deceleration does not exceed the limits defined in a) and b) for more than a cumulative 15ms.

Furthermore, all structural damage must be contained within the rear impact absorbing structure.

This test must be carried out on the rear impact absorbing structure which was subjected to the test described in Article 18.9.

16.5 Steering column test

The parts referred to in Article 10.10.3 must be fitted to a representative test structure; any other parts which could materially affect the outcome of the test must also be fitted. The test structure must be solidly fixed to the ground and a solid object, having a mass of 8kg (+1%/-0) and travelling at a velocity of 7m/s, will be projected into it.

The object used for this test must be hemispherical with a diameter of 165mm (+/-1mm).

For the test, the centre of the hemisphere must strike the structure at the centre of the steering wheel along the same axis as the main part of the steering column.

During the test the striking object may not pivot in any axis and the test structure may be supported in any way provided this does not increase the impact resistance of the parts being tested.

The resistance of the test structure must be such that during the impact the peak deceleration of the object does not exceed 80g for more than 3ms, this being measured only in the direction of impact. In addition, the displacement of the steering wheel assembly during the impact must be less than 50.0mm.

After the test, all substantial deformation must be within the steering column and the steering wheel quick release mechanism must still function normally.

ARTICLE 17: ROLL STRUCTURE TESTING

17.1 Conditions applicable to both roll structure tests

- 17.1.1 All tests must be carried out in the presence of an FIA Technical Delegate and by using measuring equipment which has been calibrated to the satisfaction of the FIA Technical Delegate.
- 17.1.2 Any significant modification introduced into the structure or its fixation tested shall require that part to pass a further test.
- 17.1.3 Rubber 3mm thick may be used between the load pads and the roll structure.

17.2 Principal roll structure test

The principal roll structure shall be subjected to the following two static load tests:

- a) A load equivalent to 87kN laterally, 87kN longitudinally in a rearward direction and 86kN vertically downwards, must be applied to the top of the structure through a rigid flat pad which is 200mm in diameter and perpendicular to the loading axis.
- b) A load equivalent to 87kN laterally, 87kN longitudinally in a forward direction and 86kN vertically downwards, must be applied to the top of the structure through a rigid flat pad which is 200mm in diameter and perpendicular to the loading axis.

During the homologation test, one of the above tests, selected by the FIA Technical Delegate, will be performed only up to 80% of the load.

For each test:

- a) Initially, the pad must not contact the roll structure below $Z= 925$
- b) At any time during the test, the pad must not contact the structure below $Z= 900$
- c) Rubber 3mm thick may be used between the load pads and the roll structure.
- d) The peak load must be applied in less than three minutes and be maintained for 10 seconds.
- e) Under the load, deformation must be less than 25mm when measured along the loading axis and any structural failure limited to 100mm below the top of the roll structure when measured vertically.

During the test, the roll structure must be attached to the survival cell which is supported on its underside on a flat plate, fixed to it through its Power Unit mounting points and wedged laterally by any of the static load test pads described in Article 18.

17.3 Secondary roll structure test

- 17.3.1 One secondary roll structure complying with the FIA standard 8869-2018 Part 2 (Steel) must be used for the purpose of the following tests.
- 17.3.2 The loads may be applied using a 150mm diameter pad or through a spherical joint whose centre lies in the specified loading position.
Rubber 3mm thick may be used between the load pads and the roll structure.
- 17.3.3 For each test, peak loads must be applied in less than three minutes and be maintained for five seconds.
- 17.3.4 After five seconds of application there must be no failure of any part of the survival cell or of any attachment between the structure and the survival cell.

- 17.3.5** A load equivalent to 116kN vertically downward and 46kN longitudinally rearward must be applied at a position 810mm forward of the plane C-C and 820mm above the reference plane and positioned on the car centre plane.

During the test, the structure must be attached to the survival cell which is supported on its underside on a flat plate, fixed to it through its Power Unit mounting points and, optionally, through the front bulkhead.

- 17.3.6** A load equivalent to 93kN laterally inward and 83kN longitudinally rearward must be applied at a position 615mm forward of the plane C-C and 800mm above the reference plane to the outer surface of the structure.

During the test, the survival cell should be fixed at its rear bulkhead via its Power Unit mounts to a strongwall and supported along its lower face by a surface plate.

The survival cell may be restrained laterally and vertically at its front end by a cradle that wraps around all four sides of the survival cell. This cradle may extend as far forward as the plane A-A, but may not extend further rearwards than 600mm rearwards of the plane A-A.

The side of the survival cell that is opposite to the application point of the Halo test load may be restrained laterally by supports that conform to the sides of the survival cell. These lateral supports may extend no further forward than 200mm forward of the plane B-B, and no higher than 525mm above the reference plane.

- 17.3.7** A load of 150kN vertically upward must be applied simultaneously on the two forward fasteners of the rear attachment on the side which was determined by the FIA technical delegate.

The load must be applied through fasteners identical to the ones used for the secondary roll structure. A dummy rear attachment may be used.

Alternatively a load of 75 kN may be applied separately on each of the two forward fasteners.

During the test, the survival cell should be fixed at its rear bulkhead via its engine mounts to a strongwall and supported along its lower face by a surface plate.

The survival cell may be restrained laterally and vertically at its front end by a cradle that wraps around all four sides of the survival cell. This cradle may extend as far forward as the plane A-A, but may not extend further rearwards than 600mm rearwards of the plane A-A.

- 17.3.8** A load equivalent to 88kN vertically upward and 88kN longitudinally rearward must be applied on the axis of the front attachment.

The load must be applied through structure and fasteners identical to the ones used for the secondary roll structure.

During the test, the survival cell may be supported in any way provided this does not increase the strength of the attachments being tested.

During the test, the survival cell should be fixed at its rear bulkhead via its engine mounts to a strongwall and supported along its lower face by a surface plate.

The survival cell may be restrained laterally and vertically at its front end by a cradle that wraps around all four sides of the survival cell. This cradle may extend as far forward as the plane A-A, but may not extend further rearwards than 600mm rearwards of the plane A-A.

ARTICLE 18: STATIC LOAD TESTING

18.1 Conditions applicable to all static load tests

- 18.1.1** The FIA may require the manufacturer to carry out the tests described in Articles 18.2, 18.3, 18.4, 18.5, 18.6 and 18.10 on random or a percentage of produced survival cells intended for use. During these tests (on deflections greater than 3.0mm), the deflection across the inner surfaces must not exceed 120% of the deflection obtained on the survival cell used for the tests described in Articles 17.2 and 17.3.
- 18.1.2** Deflections and deformations will be measured at the centre of area of circular load pads and at the top of rectangular pads.
- 18.1.3** All peak loads must be applied in less than three minutes, through a ball jointed junction at the centre of area of the pad and maintained for 30 seconds.
- 18.1.4** The load and displacement shall be recorded along the axis of load application.
- 18.1.5** All tests must be carried out in the presence of an FIA Technical Delegate and by using measuring equipment which has been calibrated to the satisfaction of the FIA Technical Delegate.
- 18.1.6** A radius of 3mm is permissible on the edges of all load pads and rubber 3mm thick may be placed between them and the test structure.
- 18.1.7** In order to ensure all survival cells are manufactured in the same way, each constructor must submit the weight of every survival cell produced. These weights will be compared with that of the survival cell which was subjected to the tests in Articles 16.3, 17.2 and 17.3. If the weight differs by more than 5% from the one previously tested, the FIA reserves the right to carry out further frontal impact tests and roll structure tests.
- 18.1.8** Any significant modification introduced into any of the structures tested shall require that part to pass a further test.
- 18.1.9** All static and dynamic load tests must be performed with the secondary roll structure (whether dummy or otherwise) removed.
- 18.1.10** All static and dynamic load tests other than those mentioned in Article 18.7 and 18.9 must be performed with the Frontal Anti Intrusion Panel removed.

18.2 Survival cell side strength tests

With reference to Drawing 9, for the survival side strength tests, described in Article 15.6.3, a pad of 300mm diameter must be placed against the side of the survival cell. The centre of the pad must be 250mm +/- 100mm behind plane B-B and 350mm +/-100mm above the reference plane. The exact position of the pad will be defined by the FIA Technical Delegate prior the homologation test.

The pad must conform to the shape of the survival cell.

During the test, the survival cell should be fixed at its rear bulkhead via its engine mounts to a strongwall and supported along its lower face by a surface plate.

The survival cell may be restrained laterally and vertically at its front end by a cradle that wraps around all four sides of the survival cell. This cradle may extend as far forward as the plane A-A, but may not extend further rearwards than 600mm rearwards of the plane A-A.

The side of the survival cell that is opposite to the application point of the test load may be restrained laterally by supports that conform to the sides of the survival cell. These lateral supports may extend no further forward than 200mm forward of the plane B-B, and no higher than 525mm above the reference plane.

The load of 300 kN shall be applied, in less than 3 minutes and maintained for a minimum of 5 seconds.

Under the load, there must be no structural failure of the inner or outer surfaces of the survival cell and the total deflection must not exceed 30mm.

18.3 Survival cell floor test

A pad of 200mm diameter must be placed in the centre of area of the fuel tank and a vertical upwards load of 30kN applied.

During the test, the survival cell should be fixed at its rear bulkhead through its engine mounting points and, optionally, through the front bulkhead.

There must be no structural failure of the inner or outer surfaces of the survival cell.

Permanent deformation must be less than 1.0mm after the load has been released for 1 minute.

18.4 Cockpit floor test

A pad of 200mm diameter must be placed beneath the survival cell, on the car centre plane and with its centre 750mm forward of the plane C-C, and a vertical upwards load of 40kN applied.

During the test, the survival cell should be fixed at its rear bulkhead through its engine mounting points and, optionally, through the front bulkhead.

There must be no structural failure of the inner or outer surfaces of the survival cell.

Permanent deformation must be less than 1.0mm after the load has been released for 1 minute.

18.5 Cockpit rim test

Two pads, each of which is 50mm in diameter, must be placed on both sides of the cockpit rim with their upper edges at the same height as the top of the cockpit side with their centres at a point 250mm forward of the plane C-C.

A constant transverse horizontal load of 30kN will then be applied at 90° to the car centre plane

During the test, the survival cell should be supported on its underside on a flat plate, and longitudinally constrained at its rear and front bulkheads.

Under the load, deformation must be less than 10mm when measured along the loading axis on a point symmetric about the centre plane.

There must be no structural failure of the inner or outer surfaces of the survival cell.

Permanent deformation must be less than 1.0mm after the load has been released for 1 minute.

18.6 Suspension pick-up test

The manufacturer must provide a detailed calculation reporting:

- a. The buckling load for each leg of the suspension members located behind the front wheel center line. The buckling force should be applied to one extremity along the line passing through the centers of the spherical joints of the relevant leg
- b. A detailed calculations showing that each suspension attachment behind the front wheel centre line and the structure surrounding it, are able to sustain 150% of the buckling load of the relevant leg, applied along Y. The complete survival cell should be modelled and vertically constrained on its reference plane, longitudinally at the AA and PU surfaces, laterally constrained via the symmetric suspension attachment.

At the discretion of the Technical Delegate a load equivalent to the 120% of the buckling load of the relevant suspension leg should be applied along Y at each of the front suspension pickup points located behind the front wheel center line.

During the test, the survival cell should be supported on its underside on a flat plate, and longitudinally constrained at its rear and front bulkheads, laterally constraining the symmetric suspension attachment.

After 30 seconds of application, there must be no structural failure of the inner or outer surfaces of the survival cell.

Permanent deformation must be less than 1.0mm after the load has been released for 1 minute.

18.7 Side Intrusion Test

18.7.1 Main Combined Panel Performance Assessment

The test panel representing the Sidewall Laminate described in Art.15.5.1 must be tested according to the procedure described by the Appendix 01/21. The maximum load measured while pushing the truncated cone against the panel sample shall exceed 250kN and the energy absorption shall exceed 6,000J within the first 100mm of loaded displacement.

18.7.2 Main Secondary Panel Performance Assessment

The test panel representing the Main Secondary Laminate described in Art.15.5.2.i must be tested according to the procedure described by the Appendix 01/21. The maximum load measured while pushing the rectangular impactor against the secondary panel sample shall exceed 275kN within the first 50mm of loaded displacement.

18.7.3 Forward Secondary Panel Performance Assessment

The test panel representing the Forward Secondary Laminate described in Art.15.5.3.i must be tested according to the procedure described by the Appendix 01/21. The maximum load measured while pushing the rectangular impactor against the forward secondary panel sample shall exceed 165kN within the first 50mm of loaded displacement.

18.7.4 Main Integrated Panel Performance Assessment

The test panel representing the Main Integrated Laminate described in Art.15.5.2.ii must be tested according to the procedure described by the Appendix 01/21. The maximum load measured while pushing the rectangular impactor against the panel sample shall exceed 400kN and the energy absorption shall exceed 6,000J within the first 50mm of loaded displacement.

18.7.5 Forward Integrated Panel Performance Assessment

The test panel representing the Forward Integrated Laminate described in Art.15.5.3.ii must be tested according to the procedure described by the Appendix 01/21. The maximum load measured while pushing the rectangular impactor against the forward panel sample shall exceed 325kN and the energy absorption shall exceed 6,000J within the first 50mm of loaded displacement.

There must be no systematic damage to the border or damage to the fixture before these requirements have been met.

18.8 Nose push off test

During the test the survival cell must be resting on a flat plate and secured to it solidly but not in a way that could increase the strength of the attachments being tested.

A constant load normal to Centre Plane shall be applied to one side of the impact absorbing structure using a ball-jointed pad, rubber or foam may be used between the pad and the test structure. The pad cannot extend to any point having $X_A > -200$.

The point of application of the force should be such that:

- the reaction moment calculated around a vertical axis which is intersecting the car centre plane and the plane AA, exceeds 40 kNm.
- The resultant of the load shall intersect Centre Plane at mid mid-point of the height of the structure at the plane selected above.

The exact position of the pad will be defined by the FIA Technical Delegate prior the homologation test.

After 30 seconds of application, there must be no failure of the structure or of any attachment between the structure and the survival cell.

18.9 Rear impact structure push off test

During the test the gearbox and the structure must be solidly fixed to the ground but not in a way that could increase the strength of the attachments being tested.

The gearbox and crash structure will be subjected to the following separate tests:

- a) A lateral load of 40kN applied at the mid height of the structure at a point 500mm behind the rear wheel centre line applied using a pad measuring 100mm in X and at least 150mm in Z.
- b) A load of 40kN vertically upwards applied on the car centre plane at a point 500mm behind the rear wheel centre line applied using a pad measuring 100mm in X and at least 100mm in Y.
- c) A load of 40kN vertically downwards applied on the car centre plane at a point 500mm behind the rear wheel centre line using a pad measuring 100mm in X and at least 100mm in Y.

The centre of the pad area must pass through the plane mentioned above and the mid point of the height of the structure at the relevant section. After 30 seconds of application, there must be no failure of the structure or of any attachment between the structure and the gearbox.

18.10 Frontal anti-intrusion panel test

18.10.1 The frontal anti-intrusion panel must be mounted on a frame as defined in the FIA Test Procedure.

A copy of the test procedure may be found in the Appendix to the Technical Regulations.

18.10.2 The frontal anti-intrusion panel will be tested by forcing the impactor through the centre of the panel until a load of minimum 300kN is reached.

During the test, the deflection, measured by the displacement of the impactor, under load must be less than 50.0 mm.

18.11 Seat bulkhead test

The parts of the survival cell immediately behind the driver (described by Art.15.3) shall be subjected to two static load tests:

- a. A load equivalent to 14kN be applied with the resultant force passing by a point lying on the bulkhead surface at the coordinates (Y:0, Z: 400) in a rearward direction normal to the local surface.
- b. A load equivalent to 14kN be applied with the resultant force passing by a point lying on the bulkhead surface at the coordinates (Y:0, Z: 140) in a rearward direction normal to the local surface.

The load shall be applied using cylindrical ball-jointed pads having a diameter of 160mm, the contact surfaces should conform to the shape of the survival cell.

The test will be performed without the extractable seat and the seat gap fillers.

During the test the survival cell must be resting on a flat plate and secured to it solidly but not in a way that could increase the strength of the area being tested.

Under the load, there must be no structural failure of the inner or outer surfaces of the survival cell and the total deflection must not exceed 30mm.

ARTICLE 19 : FUEL

19.1 Fuel

The fuel must comply with ISC Appendix J Article 252.9.1.

19.2 Air

Only air may be mixed with the fuel as an oxidant.

ARTICLE 20 : FINAL TEXT

The final text for these regulations shall be the English version which will be used should any dispute arise over their interpretation.

Headings and typeface in this document are for ease of reference only and do not form part of these Technical Regulations.

APPENDIX 1: DRAWINGS

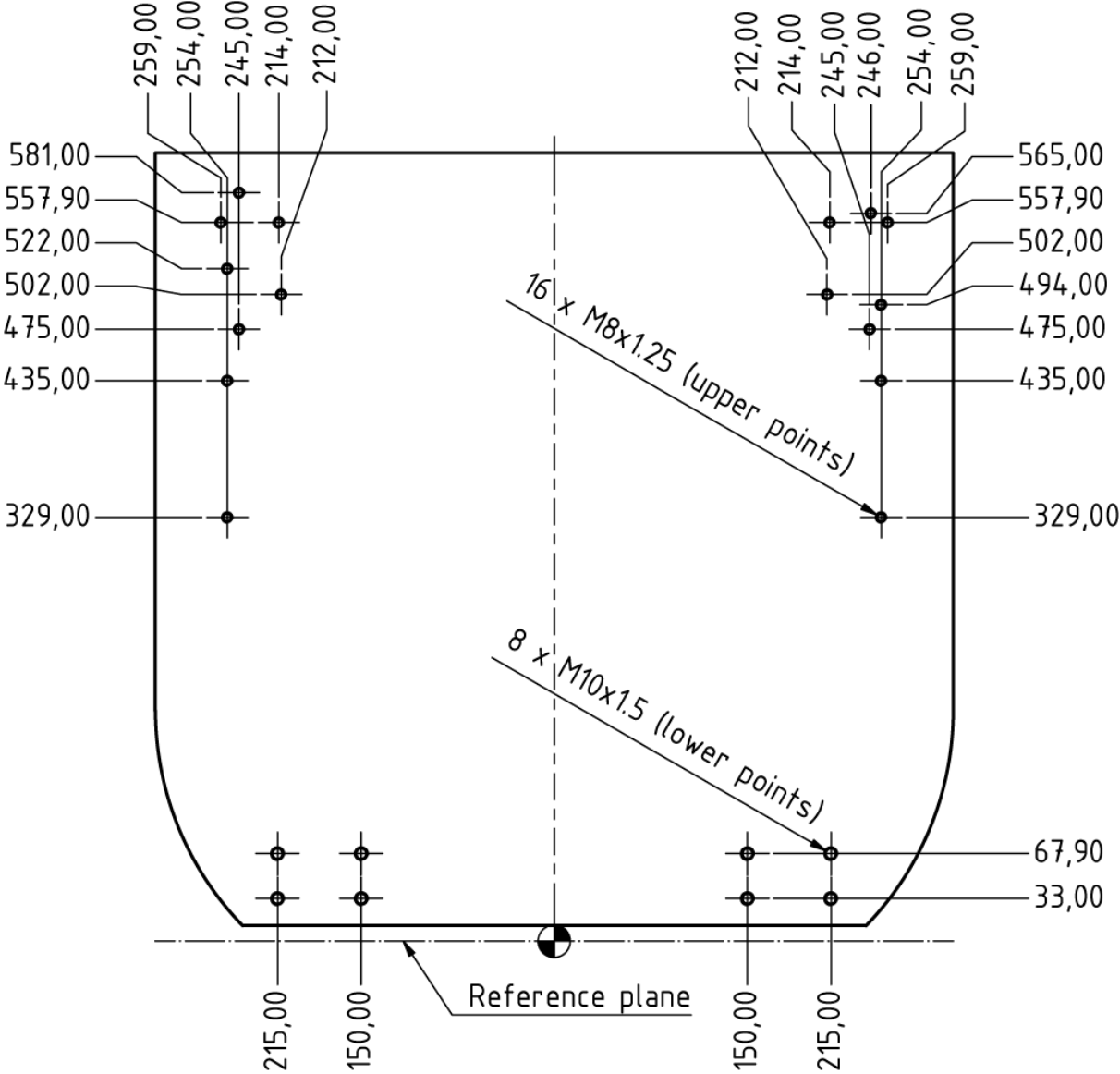

Drawing 1

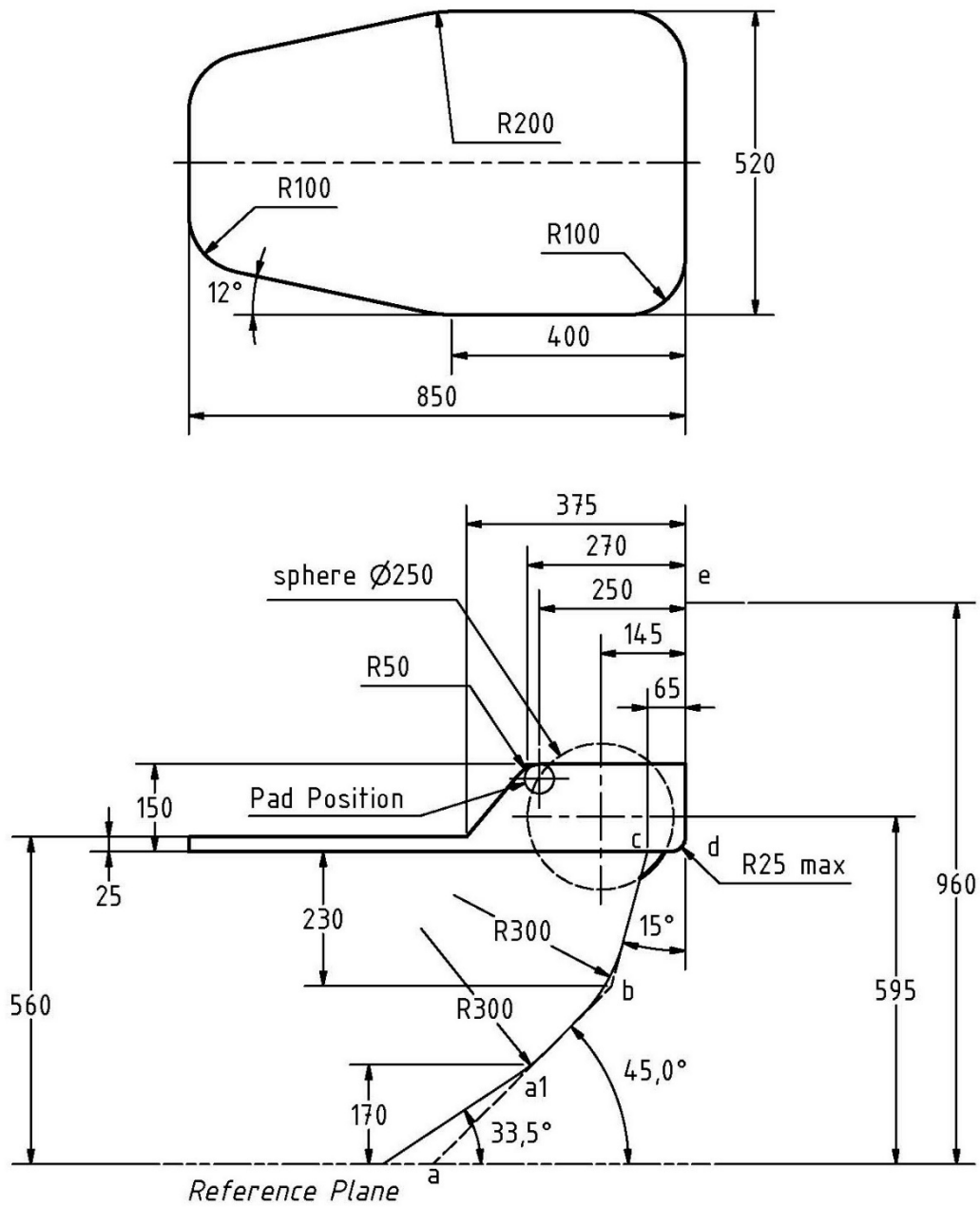

Drawing 2

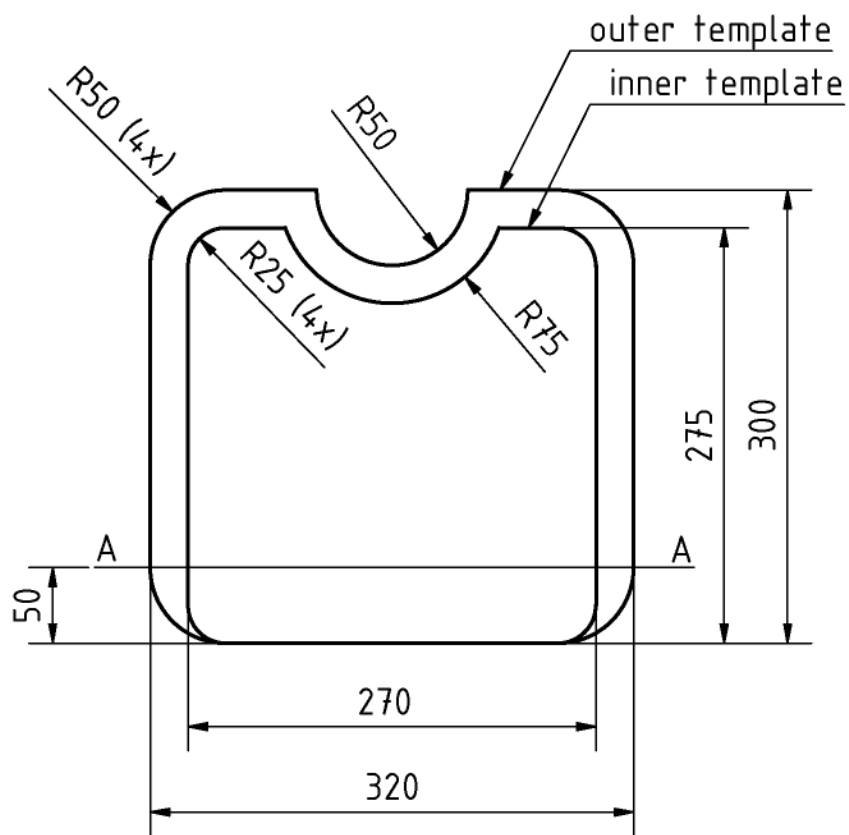

Drawing 3

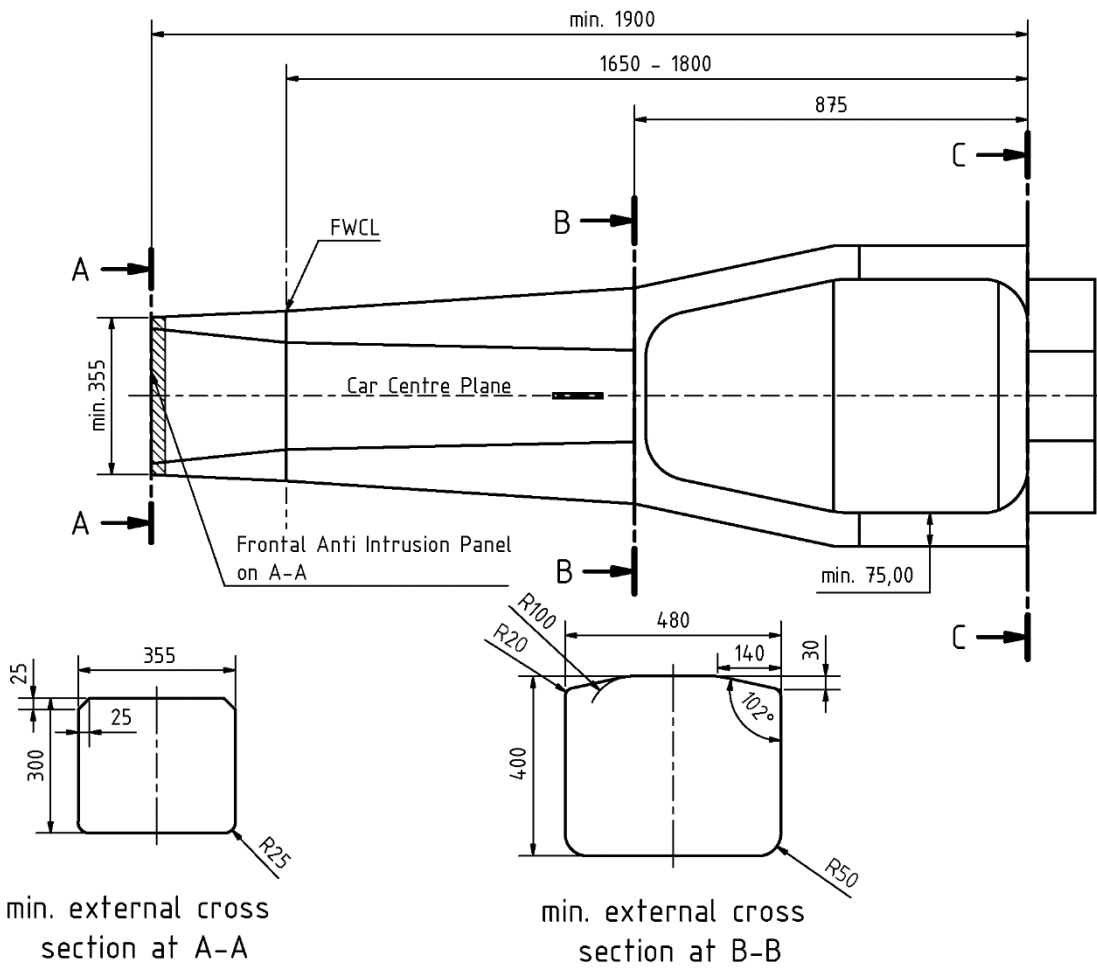

Drawing 4

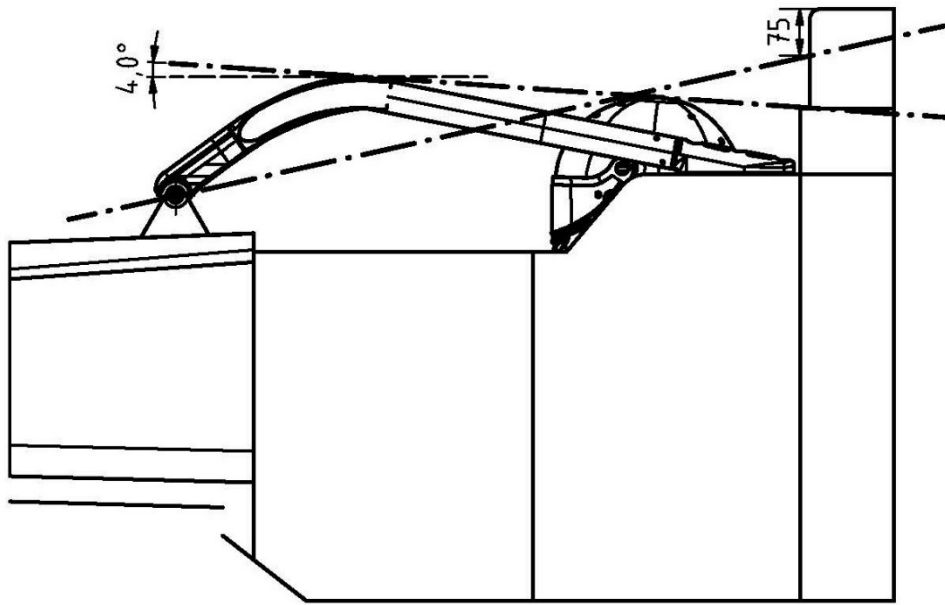

Drawing 5

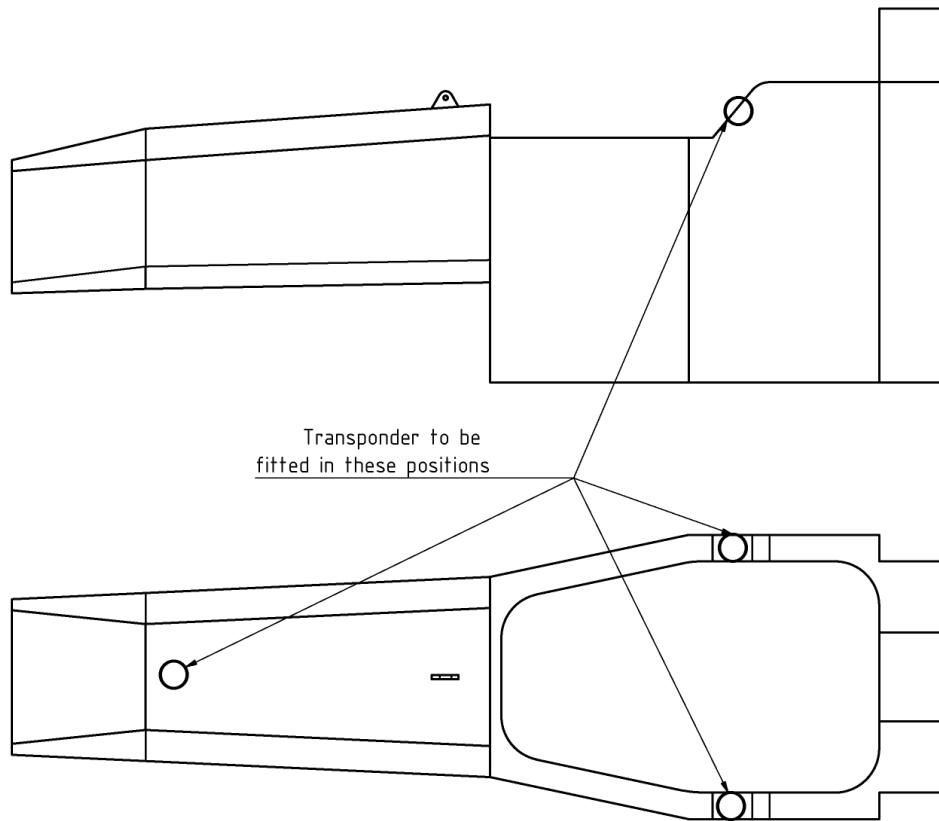

Drawing 7

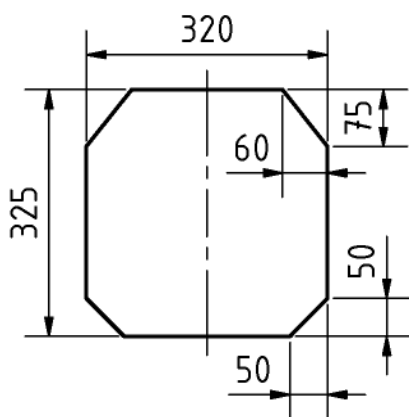

Drawing 8

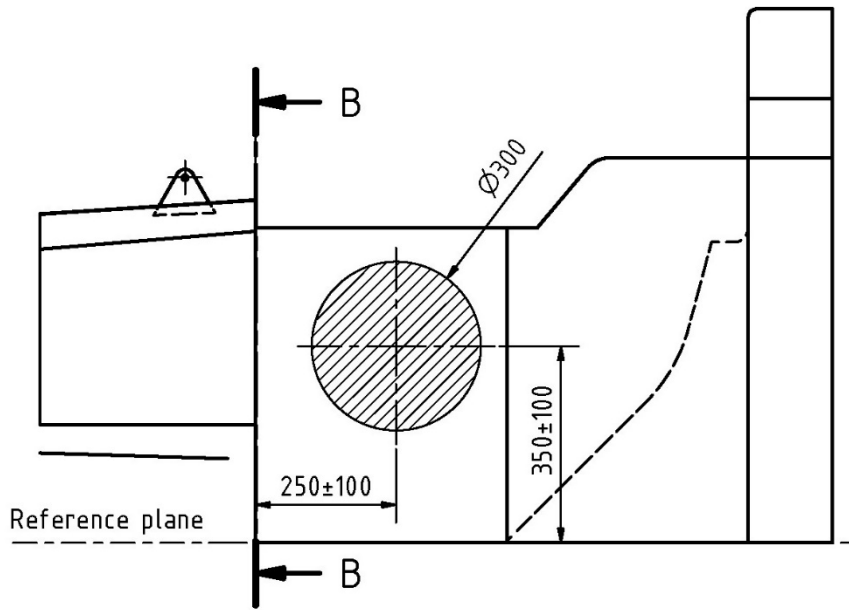

Drawing 9

APPENDIX 2: COMMON CONNECTION INTERFACE

8STA 010/35 SN // 8STA 618 35 PN

1	VREF#1 - Pedal A
2	Steering Angle
3	VREF#2 - Pedal B
4	Pedal A Position
5	GND#1 - Pedal A
6	P Brake Front
7	P Brake Rear
8	GND#2 - Pedal B
9	Pedal B Position
10	Analog #1
11	Analog #2
12	Analog #3
13	Analog #4
14	Analog #5
15	Gear Position
16	Analog #6
17	VREF#3
18	GND#3
19	+30 (GroupA)
20	+15 (GroupA)
21	+15 (GroupA)
22	+15 (GroupB)
23	Analog #7
24	Analog #8
25	CAN#1 H
26	CAN#1 L
27	+30 (GroupB)
28	+30 (GroupA)
29	+15 (GroupA)
30	+15 (GroupB)
31	+15 (GroupB)
32	VREF#4
33	GND#4
34	CAN#2 H
35	CAN#2 L
36	+30 (GroupB)
37	+15 (GroupC)
38	+15 (GroupD)
39	+15 (GroupD)
40	Starter

41	Digital Supply
42	Digital GND
43	CAN#3 H
44	CAN#3 L
45	+15 (GroupC)
46	+15 (GroupC)
47	+15 (GroupD)
48	Starter
49	Starter
50	Wheel speed FL
51	Shield
52	ETH RX+
53	ETH RX-
54	Digital Supply
55	Digital GND
56	Wheel Speed FR
57	Wheel Speed RL
58	ETH TX+
59	ETH TX-
60	Ignition switch
61	Pit Limiter Command
62	PWM Command
63	Wheel Speed RR
64	Ignition switch IN
65	Pit Limiter IN
66	Main Relay Command

APPENDIX 3: APPROVAL OF SAFETY STRUCTURES

Approval of Safety Structures for Formula Regional cars

1) Safety structures

The following safety structures need to be approved by the FIA:

- a) Survival cell.
- b) Front and rear rollover structures.
- c) Frontal impact absorbing structure.
- d) Rear impact absorbing structure.

To approve any of the above structures, the presence of an FIA technical delegate is necessary. The static load tests need to be carried out with a measuring equipment verified by the FIA; the dynamic impact tests need to be carried out at an FIA approved institute.

2) Request for approval

To get the approval of one of the above mentioned safety structures, the FIA must receive a request from the rolling chassis manufacturer at the following address beforehand:

FIA Single-Seater Department
2 Chemin de Blandonnet
CH 1215 Geneva 15
Switzerland
Tel : +41 22 544 4400
Fax : +41 22 544 4450

3) Approval procedure

Having received a request for any of the above mentioned tests, the FIA will arrange a date and venue with the rolling chassis manufacturer and will appoint a technical delegate to supervise these scheduled tests.

For each day spent by an FIA technical delegate to supervise any scheduled tests, the manufacturer will be charged a fee, of €3600.

When all the safety structure tests are carried out successfully and the manufacturer has settled the FIA fee, he will receive the FIA chassis test report for his car.

The rolling chassis manufacturer is obliged to supply all his customers with a copy of the FIA chassis test report together with the survival cell.

APPENDIX 4: REFERENCE VOLUMES AND SURFACES

1. Front Wing Reference Volume (RV-FW)

RV-FW is defined as the volume between the following planes:

- a. $Z=70$ and $Z=220$
- b. A plane normal to the reference plane defined by the points:
 $[X_F, Y] = [-678, 0]$ and $[-440, 620]$
- c. A plane normal to the reference plane defined by the points:
 $[X_F, Y] = [-1158, 0]$ and $[-920, 620]$
- d. $Y=0$ and $Y=620$

2. Front Wing Endplate Reference Volume (RV-FWEP)

On the plane $X_F=-350$, **RV-FWEP** is defined by the following peripheral elements:

- a. A straight line between $[590, 350]$ and $[590, 50]$
- b. A straight line between $[590, 50]$ and $[705, 50]$
- c. A straight line between $[705, 50]$ and $[705, 90]$
- d. A straight line between $[705, 90]$ and $[635, 90]$
- e. A straight line between $[635, 90]$ and $[635, 350]$
- f. A straight line between $[635, 350]$ and $[590, 350]$
- g. An extrusion of these elements along X to $X_F= -930$ to form a solid
- h. A plane normal to the car centre plane defined by the points:
 $[X_F, Z] = [-600, 350]$ and $[-920, 160]$
- i. The solid in (g) should then be trimmed by the plane in (h), with all material above the plane discarded

3. Front Wing Endplate Reference Surface (RS-FWEP-FP)

On the plane $Z=50$, **RS-FWEP-FP** is defined by straight lines connecting the following points:

- a. $[X_F=-360, 620]$
- b. $[X_F=-360, 695]$
- c. $[X_F=-900, 695]$
- d. $[X_F=-900, 620]$

4. Front Wing Endplate Minimum Reference Surface (RS-FWEP-MIN)

On the plane $Y=600$, **RS-FWEP-MIN** is defined by straight lines connecting the following points:

- a. $[X_F=-410, 325]$
- b. $[X_F=-410, 75]$
- c. $[X_F=-900, 75]$
- d. $[X_F=-900, 125]$

In addition:

- e. An arc with a constant radius of 780mm, extending from $[X_F=-410, 325]$ to $[X_F=-900, 125]$.
The arc's centre of curvature must lie below $Z=0$

5. Front Wing Flap Reference Surface (RS-FW-FLAP)

On the plane $Z=0$, **RS-FW-FLAP** is defined by the following peripheral elements:

- a. A straight line between $[X_F=-670, 200]$ and $[X_F=-650, 325]$
- b. A straight line between $[X_F=-650, 325]$ and $[X_F=-505, 590]$
- c. A straight line between $[X_F=-505, 590]$ and $[X_F=-655, 590]$
- d. A straight line between $[X_F=-655, 590]$ and $[X_F=-835, 200]$
- e. A straight line between $[X_F=-715, 0]$ and $[X_F=-880, 0]$
- f. A minor circular arc from $[X_F=-715, 0]$ to $[X_F=-670, 200]$ tangent to Y at $[X_F=-715, 0]$ with its centre rearwards of $X_F=-715$.
- g. A minor circular arc from $[X_F=-880, 0]$ to $[X_F=-835, 200]$ tangent to Y at $[X_F=-880, 0]$ with its centre rearwards of $X_F=-880$.

6. Front Wing Fishplate Reference Volume (RV-FW-FISHPLATE)

RV-FW-FISHPLATE is defined as the volume between the following planes:

$Z=80$ and $Z=220$

A plane normal to the reference plane defined by the points:

$[X_F, Y] = [-718, 0]$ and $[-480, 620]$

A plane normal to the reference plane defined by the points:

$[X_F, Y] = [-1193, 0]$ and $[-885, 620]$

A plane defined by the points:

$[X_F, Y, Z] = [-838, 0, 220]$ and $[-1123, 0, 110]$ and $[-835, 750, 110]$

$Y=195$ and $Y=225$

7. Front Upper Chassis Reference Surface (RS-FRT-UPR)

RS-FRT-UPR is a surface tangent to Y at $Y=0$, defined by the following peripheral elements:

- a. On the plane $Y=0$, a straight line between $[X_B=85, 610]$ and $[X_B=-350, 610]$
- b. On the plane $Y=0$, a minor circular arc from $[X_B=-350, 610]$ to $[X_D=350, 365]$ tangent to X at $[X_B=-350, 610]$ with its centre below $Z=0$
- c. On the plane $Y=0$, a minor circular arc from $[X_D=350, 365]$ to $[X_D=0, 200]$ tangent to b at $[X_D=350, 365]$ with its centre below $Z=0$
- d. On the plane $X_B=85$, a minor circular arc from $[0, 610]$ to $[345, 520]$ tangent to Y at $[0, 610]$ with its centre below $Z=610$
- e. On the plane $X_B=-350$, a minor circular arc from $[0, 610]$ to $[345, 520]$ tangent to Y at $[0, 610]$ with its centre below $Z=610$
- f. On the plane $X_D=350$, a minor circular arc from $[0, 365]$ to $[345, 335]$ tangent to Y at $[0, 365]$ with its centre below $Z=350$
- g. On the plane $X_D=0$, a straight line between $[0, 200]$ and $[345, 200]$
- h. On the plane $X_A=-1100$, a straight line between $[0, 200]$ and $[345, 200]$
- i. On the plane $Y=345$, a straight line between $[X_B=85, 520]$ and $[X_B=X_B=-350, 520]$
- j. On the plane $Y=345$, a minor circular arc from $[X_B=-350, 520]$ to $[X_D=350, 335]$ tangent to h i. at $[X_B=-350, 520]$ with its centre below $Z=0$
- k. On the plane $Y=345$, a minor circular arc from $[X_D=350, 335]$ to $[X_D=0, 200]$ tangent to j. at $[X_D=350, 335]$ with its centre below $Z=0$

- l. Once the surface has been fully defined, it must be trimmed to a plane normal to the reference plane defined by the following points:
 $[X_A, Y] = [-1100, 110]$ and $[X_C, Y] = [-620, 310]$
- m. All material outboard of the plane defined in l. must be discarded
- n. On the plane $Y=0$, a straight line between $[X_B=85, 610]$ and $[X_B=85, 570]$
- o. On the plane $Y=0$, a straight line between $[X_B=85, 570]$ and $[X_C=-410, 580]$
- p. On the plane $Y=0$, a line from $[X_D=0, 200]$ to $[X_A=-1100, 200]$
- q. An extrusion of elements n., o. and p. along Y to $Y=345$ to form a surface
- r. Once the surface has been fully defined, it must be trimmed to the plane in l.
- s. All material outboard of the plane defined in l. must be discarded

8. Front Upper Chassis Minimum Reference Surface (RS-FRT-MIN)

On the plane $Y=0$, **RS-FRT-MIN** is defined by the following peripheral elements:

- a. A point at $[X_B=-250, 585]$
- b. A point at $[X_A=-700, 310]$
- c. A minor circular arc from $[X_B=-250, 585]$ to $[X_A=-700, 310]$ tangent to X at $[X_B=-250, 585]$ with its centre below $Z=0$.
- d. An extrusion of (c) along Y to $Y=50$

9. Front Lower Chassis Reference Volume (RV-FRT-LWR)

RV-FRT-LWR is defined by the volume between the following planes:

- a. $X_F=-350$ and $X_C=-1200$
- b. $Z=0$ and $Z=100$
- c. $Y=0$ and $Y=750$

10. Front Chassis Exclusion Zone Reference Volume (RV-FRT-EXCL)

RV-FRT-EXCL defined by the volume between the following planes:

- a. $X_A=-1100$
- b. $Y=925$
- c. $Z=960$
- d. A plane normal to the reference plane defined by the points:
 $[X_A, Y] = [-1100, 110]$ and $[X_C, Y] = [-620, 310]$
- e. A plane normal to the reference plane defined by the points
 $[X_C, Y] = [-620, 310]$ and $[X_C, Y] = [-220, 925]$

11. Sidepod Leading Edge Reference Volume (RV-SPOD-LE)

RV-SPOD-LE is defined as the volume between the following planes:

- a. $Z=210$ and $Z=550$
- b. $Y=260$ and $Y=750$
- c. $X_C=-300$
- d. A plane normal to the reference plane defined by the points
 $[X_C, Y] = [-620, 310]$ and $[X_C, Y] = [-330, 750]$

12. Sidepod Leading Edge Reference Surface (RS-SPOD-LE)

On the plane $Z=460$, **RS-SPOD-LE** is defined by straight lines connecting the following points:

- a. $[X_c = -576, 350]$
- b. $[X_c = -300, 350]$
- c. $[X_c = -300, 670]$
- d. $[X_c = -410, 600]$

13. Chassis Mid Reference Volume (RV-CH-MID)

RV-CH-MID is defined as the volume between the following planes:

- a. $X_c = -300$ and $X_{PU} = 0$
- b. $Y = 260$ and $Y = 350$
- c. $Z = 460$ and $Z = 960$

14. Rear Bodywork Engine Cover Reference Volume (RV-RBW-EC)

On the plane $Y=0$, **RV-RBW-EC** is defined by the following peripheral elements:

- a. A straight line between $[X_{PU} = 0, 210]$ and $[X_{PU} = 0, 960]$
- b. A straight line between $[X_{PU} = 0, 960]$ and $[X_{PU} = 210, 960]$
- c. A straight line between $[X_{PU} = 210, 960]$ and $[X_R = -15, 615]$
- d. A straight line between $[X_R = -15, 615]$ and $[X_R = 242, 615]$
- e. A straight line between $[X_R = 242, 615]$ and $[X_{PU} = 242, 250]$
- f. A straight line between $[X_R = 242, 250]$ and $[X_R = -195, 250]$
- g. A straight line between $[X_R = -195, 250]$ and $[X_R = -195, 210]$
- h. A straight line between $[X_R = -195, 210]$ and $[X_{PU} = 0, 210]$
- i. An extrusion of these elements along Y to $Y=750$ to form a solid
- j. A plane normal to the plane $Y=0$ defined by the points: $[X_R, Z] = [185, 550]$ and $[X_R, Z] = [50, 210]$
- k. The volume in (i) should be trimmed using the plane defined in (j) with all material rearwards of the plane discarded
- l. A plane normal to the Reference Plane defined by the points: $[X_{PU}, Y] = [0, 750]$ and $[X_{PU}, Y] = [210, 683]$
- m. The volume in (k) should be trimmed using the plane defined in (l) with all material outboard discarded
- n. On the plane $Y=0$, a straight line between $[X_R = -300, 715]$ and $[X_R = 275, 715]$
- o. On the plane $Y=0$, a straight line between $[X_R = 275, 715]$ and $[X_R = 275, 510]$
- p. On the plane $Y=0$, a straight line between $[X_R = 275, 510]$ and $[X_R = -300, 510]$
- q. On the plane $Y=0$, a straight line between $[X_R = -300, 510]$ and $[X_R = -300, 715]$
- r. An extrusion of these elements along Y to $Y=25$ to form a solid
- s. The volume in (r) should be combined with the volume in (m)
- t. On the plane $X_{PU} = 0$, a straight line between $[400, 615]$ and $[750, 615]$
- u. On the plane $X_{PU} = 0$, a straight line between $[400, 615]$ and $[75, 960]$
- v. On the plane $X_R = -300$, a straight line between $[250, 615]$ and $[750, 615]$
- w. On the plane $X_R = -300$, a straight line between $[250, 615]$ and $[0, 960]$
- x. A linear sweep between these elements to form a surface
- y. The volume in (s) should be trimmed using the surface defined in (y) with all material above discarded

15. Rear Bodywork Engine Cover Reference Surface (RS-RBW-EC)

On the plane $Y=0$, **RS-RBW-EC** is defined by straight lines connecting the following points:

- a. $[X_{PU}=0, 925]$
- b. $[X_{PU}=150, 925]$
- c. $[X_R=-200, 650]$
- d. $[X_R=200, 685]$
- e. $[X_R=125, 450]$
- f. $[X_{PU}=0, 450]$

16. Rear Bodywork Sidepod Reference Volume (RV-RBW-SPOD)

RV-RBW-SPOD is defined as the volume between the following planes:

- a. $X_C=-300$ and $X_{PU}=0$
- b. $Y=350$ and $Y=750$
- c. $Z=210$ and $Z=550$

17. Rear Bodywork Aperture Reference Volume (RV-RBW-APERTURE)

RV-RBW-APERTURE is defined as the volume between the following planes:

- a. $Z=350$ and $Z=550$
- b. $Y=375$
- c. $X_C=-300$ and $X_C=450$
- d. A plane normal to the reference plane defined by the points $[X_C, Y] = [-300, 675]$ and $[X_C, Y] = [450, 550]$

18. Rear Bodywork Aperture Reference Surface (RS-RBW-APERTURE)

On the plane $Z=400$, **RS-RBW-APERTURE** is defined by straight lines connecting the following points:

- a. $[X_C=-300, 375]$
- b. $[X_C=-300, 675]$
- c. $[X_C=450, 550]$
- d. $[X_C=450, 375]$

19. Rear Wing Endplate Body Reference Volume (RV-RWEP-BODY)

On a plane $X_R=690$, **RV-RWEP-BODY** is defined by the following peripheral elements:

- a. A straight line between $[Y, Z] = [500, 850]$ and $[500, 650]$
- b. A straight line between $[Y, Z] = [500, 650]$ and $[365, 420]$
- c. A straight line between $[Y, Z] = [365, 420]$ and $[365, 300]$
- d. A straight line between $[Y, Z] = [365, 300]$ and $[415, 300]$
- e. A straight line between $[Y, Z] = [415, 300]$ and $[415, 410]$
- f. A straight line between $[Y, Z] = [415, 410]$ and $[550, 625]$
- g. A straight line between $[Y, Z] = [550, 625]$ and $[550, 850]$
- h. A straight line between $[Y, Z] = [550, 850]$ and $[500, 850]$
- i. An extrusion of these elements along X to $X_R=150$ to form a solid

- j. A plane normal to $Y=0$ defined by the points
 $[X_R, Z] = [160, 300]$ and $[X_R, Z] = [320, 850]$
- k. The volume in (i) should be trimmed using the plane defined in (j) with all material forwards of (i) discarded
- l. A plane parallel to the plane defined in (j), at a normal distance of 410mm in the rearward direction
- m. The volume in (k) should be trimmed using the plane defined in (l) with all material rearwards of (l) discarded

20. Rear Wing Endplate Side Reference Surface (RS-RWEP-SIDE)

On the plane $Y=0$, **RS-RWEP-SIDE** is defined by straight lines connecting the following points:

- a. $[X_R=345, 800]$
- b. $[X_R=675, 800]$
- c. $[X_R=675, 650]$
- d. $[X_R=550, 425]$
- e. $[X_R=200, 350]$

21. Floor and Diffuser Reference Volume (RV-FLOOR-DIFFUSER)

RV-FLOOR-DIFFUSER is defined as the volume between the following planes:

- a. $Z=0$ and $Z=210$
- b. $Y=0$ and $Y=750$
- c. $X_C=-1200$ and $X_R=300$

22. Reference Plane Min Reference Surface (RS-REF-MIN)

On the plane $Z=0$, **RS-REF-MIN** is defined by straight lines connecting the following points:

- a. $[X_C=-1150, 225]$
- b. $[X_C=-1150, 0]$
- c. $[X_R=-400, 0]$
- d. $[X_R=-400, 125]$
- e. $[X_R=-820, 225]$

23. Rear Bodywork Diffuser Reference Volume (RV-RBW-DIFF)

On the plane $Z=50$, **RV-RBW-DIFF** is defined by the following peripheral elements:

- a. A straight line between $[X_R=-840, 700]$ and $[X_R=-840, 0]$
- b. A straight line between $[X_R=-840, 0]$ and $[X_R=-195, 0]$
- c. A straight line between $[X_R=-195, 0]$ and $[X_R=-195, 700]$
- d. An extrusion of these elements along Z to $Z=210$ to form a solid
- e. A plane normal to the Reference Plane defined by the points: $[X_{PU}, Y] = [0, 750]$ and $[X_{PU}, Y] = [210, 683]$
- f. The volume in (d) should be trimmed using the plane defined in (e) with all material outboard discarded
- g. The volume in (f) should be trimmed using **RS-DIFFUSER** with all material below discarded

24. Top Diffuser Fins Reference Volume (RV-DIFFUSER-TOP-FINS)

- On a plane Z=55, **RV-DIFFUSER-TOP-FINS** is defined by the following peripheral elements:
- A straight line between $[X_R=-480, 575]$ and $[X_R=-255, 575]$.
 - A straight line between $[X_R=-280, 575]$ and $[X_R=-255, 590]$
 - A straight line between $[X_R=-255, 590]$ and $[X_R=-315, 590]$
 - A straight line between $[X_R=-315, 590]$ and $[X_R=-460, 660]$
 - ~~A~~ A minor arc with a constant radius of 200mm, extending from $[X_R=-480, 575]$ to $[X_R=-460, 660]$ with centre between $X_R=0$ and $X_R=-500$.
 - An extrusion of the intersection of these elements along Z to Z=105 to form a solid.

24. Lower Diffuser Fins Reference Volume (RV-DIFFUSER-LOW-FINS)

- On a plane Z=50, **RV-DIFFUSER-LOW-FINS** is defined by the following peripheral elements:
- A straight line between $[X_R=-200, 300]$ and $[X_R=-495, 500, 300]$.
 - A straight line between $[X_R=-200, 300]$ at an angle 25° to a Y plane, extending beyond $Y=425$ and forwards of $X_R=-200$.
 - An arc with a constant radius of ~~295~~ 300mm, extending from $[X_R=-495, 500, 300]$ beyond $Y=425$. The arc's centre of curvature must lie at $[X_R=-200, 300]$.
 - An extrusion of the intersection of these elements along Z to Z=150 to form a solid.
 - Once the volume d. is fully defined it must be trimmed by the lower surface defined by **RC-DIFFUSER** with all material above **RC-DIFFUSER** discarded.

25. Main Roll Structure Cover Reference Volume (RV-MRS-COVER)

RV-MRS-COVER is defined as the volume between the following planes:

- Z=790 and Z=960
- Y=0
- $X_C=0$ and $X_{PU}=0$
- A plane normal to X=0 defined by the points [55, 930] and [80, 860]

26. Main Roll Structure Minimum Reference Surface (RS-MRS-MIN)

RS-MRS-MIN is defined by the following peripheral elements:

- On a plane $X_C=5$, a straight line between [73, 795] and [30, 911]
- On a plane $X_C=5$ an arc with a constant radius, extending from [30, 911] to [0, 932], which is tangent to Y at [0, 932]. The arc's centre of curvature must lie below [0, 932]
- Once fully defined, the elements in (a) and (b) must be extruded along X to $X_C=160$ to form a surface
- A plane normal to Y=0 defined by the points: $[X_C, Z] = [165, 790]$ and $[X_C, Z] = [115, 920]$
- Once the plane in (d) is fully defined it must be used to trim the surface defined in (c) with ALL material rearwards of the plane discarded

27. Secondary Roll Structure Front Max (RV-SRS-FR-MAX)

On a plane Y=0, **RV-SRS-FR-MAX** is defined by the following peripheral elements:

- A straight line between $[X_B, Z] = [-15, 700]$ and $[X_B, Z] = [-150, 700]$
- A straight line between $[X_B, Z] = [-150, 700]$ and $[X_B, Z] = [-275, 600]$

- c. A straight line between $[X_B, Z] = [-275, 600]$ and $[X_B, Z] = [-15, 600]$
- d. A straight line between $[X_B, Z] = [-15, 600]$ and $[X_B, Z] = [-15, 700]$
- e. An extrusion of these elements along Y to $Y=60$ to form a solid
- f. A plane normal to $X=0$, defined by the following points: $[Y, Z] = [15, 700]$ and $[Y, Z] = [45, 600]$

28. Front Brake Duct Reference Volume (RV-FBD)

RV-FBD is defined as follows:

- a. On the plane $Y_w=0$ a circle of radius 155mm, extruded to $Y_w=-140$
- b. On the plane $Y_w=0$ a circle of radius 175mm, extruded to $Y_w=50$

The resulting volumes must be united to form one single volume.

29. Front Brake Duct Reference Surface (RS-FBD)

RS-FBD is defined as follows:

- a. On the plane $Y_w=0$ a circle of radius 160mm, trimmed on the plane $X_w=-5$, with all material rearwards of the plane $X_w=-5$ discarded
- b. On the plane $Y_w=0$ a circle of radius 150mm, trimmed on the plane $X_w=-5$, with all material forwards of the plane $X_w=-5$ discarded

The resulting surfaces must be united to form one single surface.

30. Rear Brake Duct Reference Volume (RV-RBD)

RV-RBD is defined as follows:

- a. On the plane $Y_w=0$ a circle of radius 155mm, extruded to $Y_w=-175$
- b. On the plane $Y_w=0$ a circle of radius 175mm, extruded to $Y_w=60$

The resulting volumes must be united to form one single volume.

31. Rear Brake Duct Reference Surface (RS-RBD)

RS-RBD is defined as follows:

- a. On the plane $Y_w=0$ a circle of radius 160mm, trimmed on the plane $X_w=0$, with all material rearwards of the plane $X_w=0$ discarded
- b. On the plane $Y_w=0$ a circle of radius 160mm, trimmed on the plane $Z_w=0$, with all material above the plane $Z_w=0$ discarded

The resulting surfaces must be united to form one single surface.

32. Survival Cell Tower Reference Surface (RS-SC-TOWER)

The surface **RS-SC-TOWER** is defined by the following peripheral elements:

- a. On a plane $Y=0$, a straight line between $[X_c, Z] = [0, 790]$ and $[X_c, Z] = [165, 790]$
- b. An extrusion of (a) along Y to $Y=90$ to form a surface
- c. On a plane $X_c=0$, a straight line between $[90, 790]$ and $[140, 650]$
- d. An extrusion of (c) along X to $X_c=165$ to form a surface
- e. On a plane $Y=260$, a straight line between $[X_c, Z] = [0, 685]$ and $[X_c, Z] = [165, 662]$
- f. An extrusion of (e) along Y to $Y=-200$ to form a surface

- g. The extruded sections in (d) and (f) must be trimmed to each other with ALL material inboard and below discarded

33. Roll Structure Reference Surface (RS-ROLL-STRUCT)

The surface **RS-ROLL-STRUCT** is defined by the following peripheral elements:

- a. On a plane $X_c=30$, a straight line between $[90, 790]$ and $[43, 920]$
- b. On a plane $X_c=30$ an arc with a constant radius, extending from $[43, 920]$ to $[0, 950]$ which is tangent to Y at $[0, 950]$. The arc's centre of curvature must lie below $[0, 950]$
- c. Once fully defined, the elements in (a) and (b) must be extruded along X to $X_c=180$ to form a surface
- d. On a plane $Y=0$, a straight line between $[X_c=30, 950]$ and $[X_c=15, 935]$
- e. Once fully defined, the element in (d) must be swept along (a) and (b) to form a surface
- f. A plane normal to $Y=0$ defined by the points $[X_c, Z] = [165, 790]$ and $[X_c, Z] = [115, 920]$
- g. Once the plane in (f) is fully defined it must be used to trim the surface defined in (c) with ALL material rearwards of the plane discarded.

34. Roll Structure Limit Reference Surface (RS-ROLL-STRUCT-LIM)

The surface **RS-ROLL-STRUCT-LIM** is defined by the following peripheral elements:

- a. On a plane $X_c=0$, a straight line between $[76, 860]$ and $[53, 923]$
- b. On a plane $X_c=0$ an arc with a constant radius, extending from $[53, 923]$ to $[0, 960]$ which is tangent to Y at $[0, 960]$. The arc's centre of curvature must lie below $[0, 960]$
- c. Once fully defined, the elements in (a) and (b) must be extruded along X to $X_c=150$ to form a surface

35. Survival Cell Lower Reference Surface (RS-SC-LWR)

On a plane $Y=0$, the surface **RS-SC-LWR** is defined by the following peripheral elements:

- a. A straight line between $[X_A, Z] = [0, 145]$ and $[X_B, Z] = [-250, 135]$
- b. An extrusion of (a) along Y to $Y=75$ to form a surface
- c. A straight line between $[X_C, Z] = [-810, 15]$ and $[X_C, Z] = [-660, 15]$
- d. An extrusion of (c) along Y to $Y=125$ to form a surface
- e. A straight line between $[X_B, Z] = [-250, 135]$ and $[X_C, Z] = [-810, 15]$
- f. An extrusion of (e) that has width that varies linearly from $Y=125$ at $[X_C, Z] = [-810, 15]$ to $Y=75$ at $[X_B, Z] = [-250, 135]$

36. Forward Fuel Limit Reference Surface (RS-FWD-FUEL-LIMIT)

On a plane $Y=0$, the surface **RS-FWD-FUEL-LIMIT** is defined by the following peripheral elements:

- a. A straight line between $[X_C, Z] = [0, 535]$ and $[X_C, Z] = [-65, 535]$
- b. A straight line from $[X_C, Z] = [-65, 535]$ at an angle of 15° to an X plane, terminating at $Z=305$ and forwards of $X_c=-50$
- c. A straight line from (b) at $Z=305$ at an angle of 45° to an X plane terminating at $Z=170$ and forwards of $X_c=-250$

- d. A straight line from (c) at $Z=170$ at an angle of 33.5° to a Z plane terminating at $Z=0$ and rearwards of $X_c=-500$
- e. An extrusion of these elements along Y to $Y=150$ to form a surface
- f. A sphere of diameter 250mm with centre at a point $[X_c, Z] = [-145, 595]$
- g. The surfaces in (e) and (f) must be trimmed to each other to form a single surface, with anything above (a) or forwards of (b) discarded.
- h. Once the surface is fully defined, radii of 300mm must be applied to the corners at $Z=170$ and $Z=305$, drawn tangent to both surfaces.