



FIA FORMULA 1 WORLD CHAMPIONSHIP



# 2026 BRITISH GRAND PRIX

03 - 05 July 2026

---

<b>From</b>	The FIA Formula 1 Media Delegate	<b>Document</b>	13
<b>To</b>	All Teams, All Officials	<b>Date</b>	03 July 2026
		<b>Time</b>	09:54

---

**Title** Car Presentation Submissions

**Description** Car Presentation Submissions

**Enclosed** 2026 British Grand Prix - Car Presentation Submissions.pdf

**Cameron Kelleher**

**The FIA Formula 1 Media Delegate**



# FIA FORMULA 1 WORLD CHAMPIONSHIP



## Car Presentation – British Grand Prix McLaren Mastercard F1 Team

	Updated component	Primary reason for update	Geometric differences compared to previous version	Brief description on how the update works (min 20, max 100 words)
1	Front Corner	Performance - Flow Conditioning	New Front Brake Duct	A new front brake duct design is introduced at this event, resulting in improved flow conditioning and gain in aerodynamic load.
2	Floor Furniture	Performance - Flow Conditioning	Revised Floor Board and Furniture	The floor board and various elements of the floor furniture have been revised, resulting in an improvement of flow physics and gain in overall efficiency.



# FIA FORMULA 1 WORLD CHAMPIONSHIP

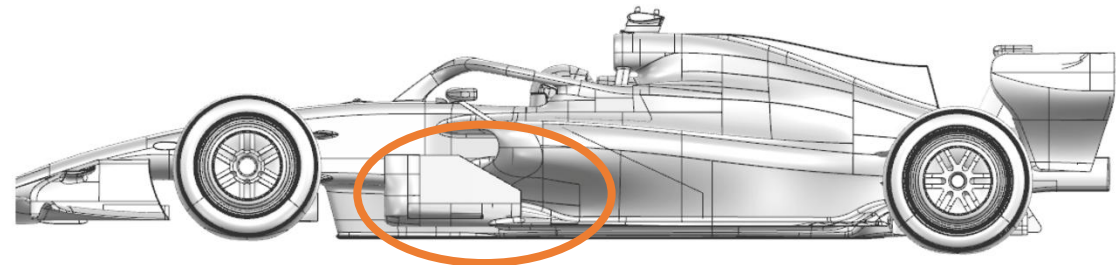
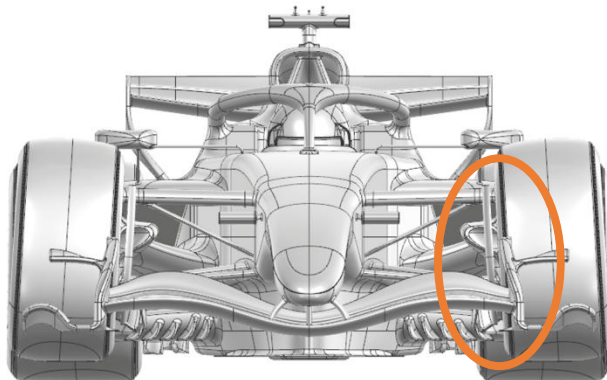
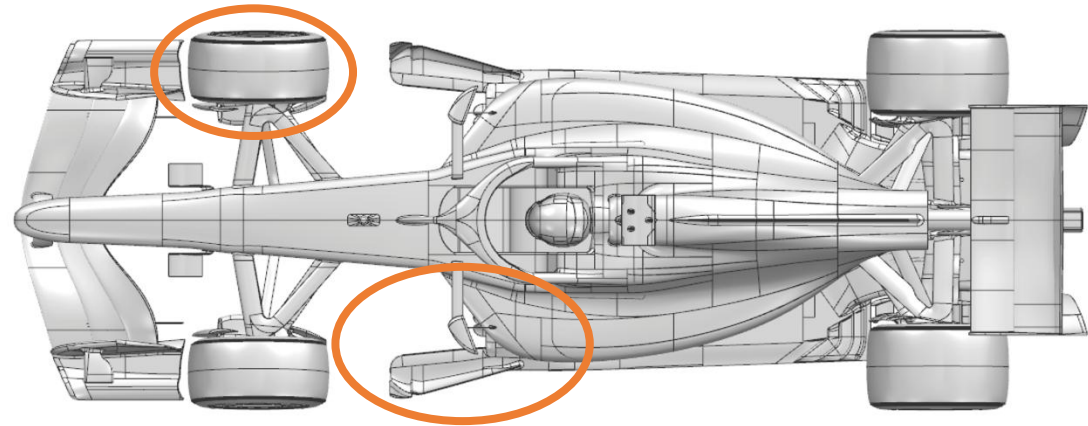
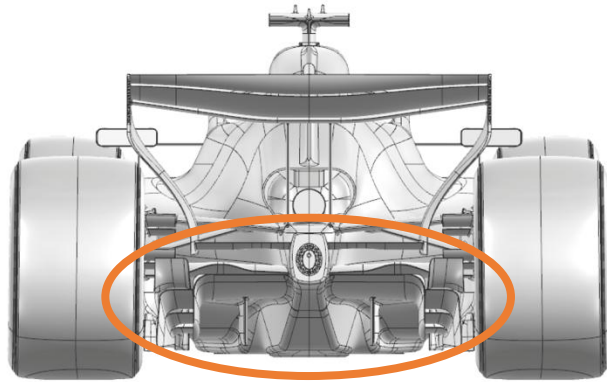



FIA FORMULA 1 WORLD CHAMPIONSHIP



**Car Presentation – 2026 British Grand Prix  
Mercedes-AMG PETRONAS F1 Team**

No updates submitted for this event.



# FIA FORMULA 1 WORLD CHAMPIONSHIP



## Car Presentation – British Grand Prix Oracle Red Bull Racing.

	Updated component	Primary reason for update	Geometric differences compared to previous version	Brief description on how the update works (min 20, max 100 words)
1	Rear Corner	Performance - Local Load	Rear wheel bodywork winglets	Inboard of the rear rims and as part of the rear wheel bodywork assembly, the cascade wings have been revised by changing the number of elements to improve the load characteristics and stability.



# FIA FORMULA 1 WORLD CHAMPIONSHIP

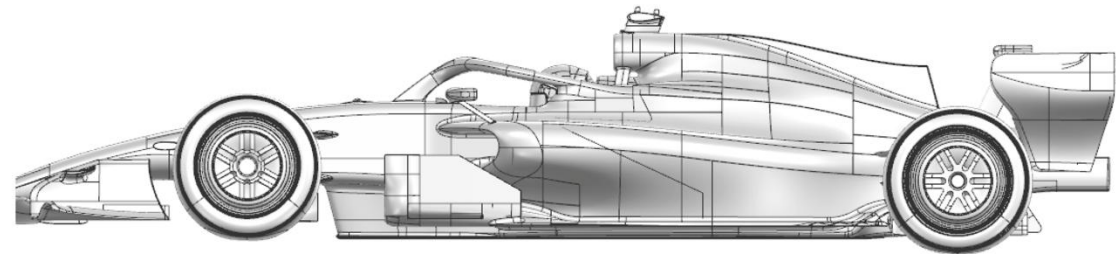
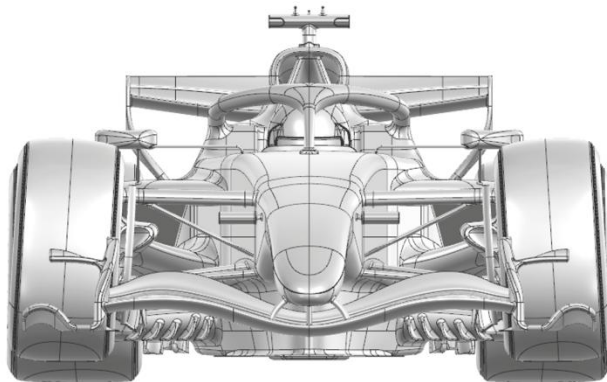
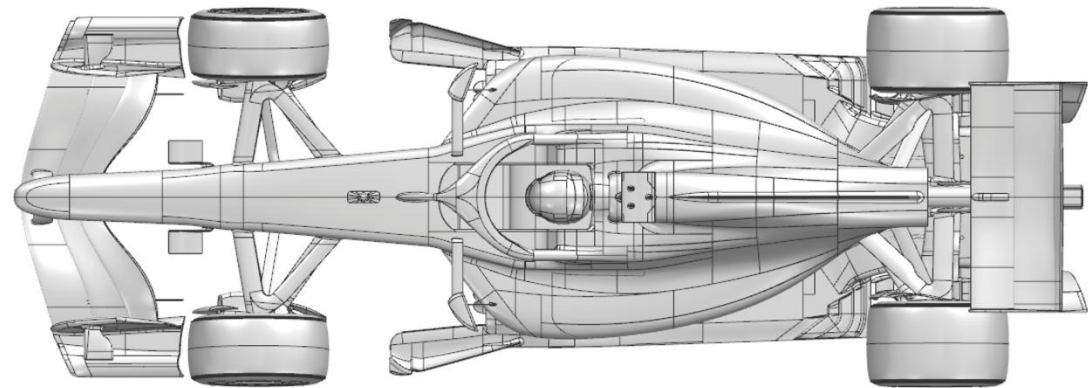
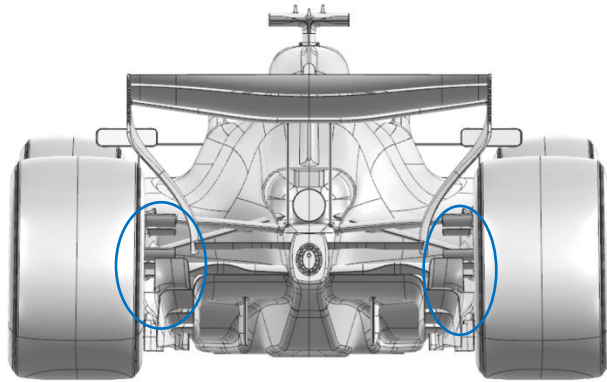



# FIA FORMULA 1 WORLD CHAMPIONSHIP



## Car Presentation – British Grand Prix SCUDERIA FERRARI HP

	Updated component	Primary reason for update	Geometric differences compared to previous version	Brief description on how the update works (min 20, max 100 words)
1	Rear Corner	Performance - Local Load and Cooling	Increased cooling inlet and outlet sections, updated lower deflector, re-optimized rearward winglet cluster	This update has 2 main objectives: corner cooling via increased inlet/outlet sections, and local loading via lower deflector redesign and winglet loading optimisation, maximizing aerodynamic efficiency



# FIA FORMULA 1 WORLD CHAMPIONSHIP

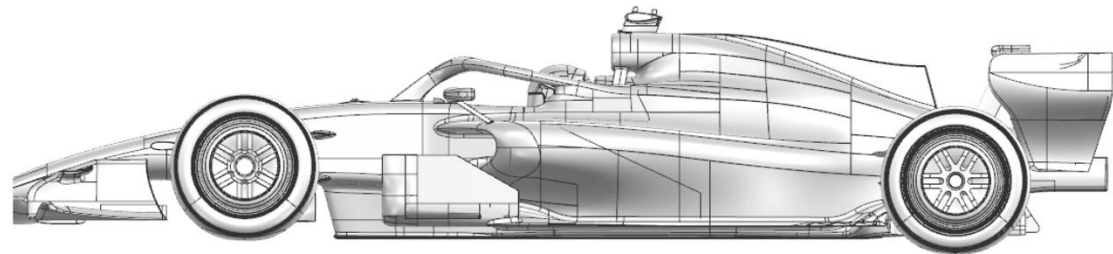
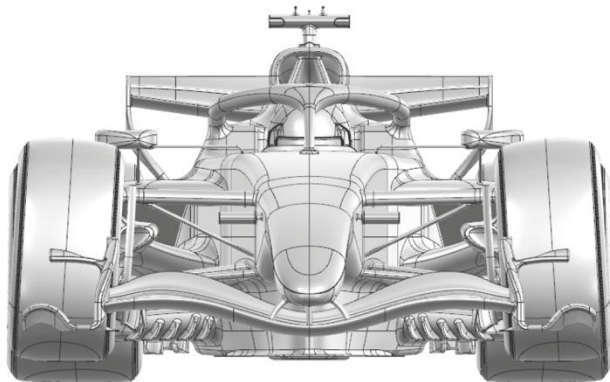
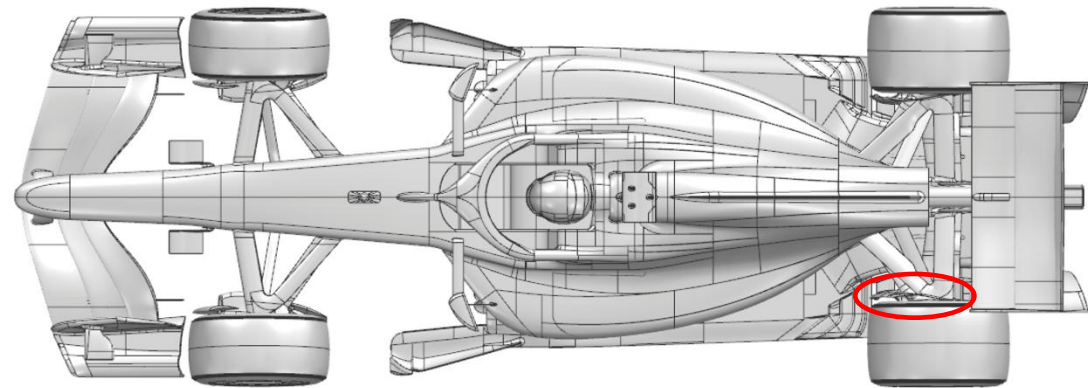
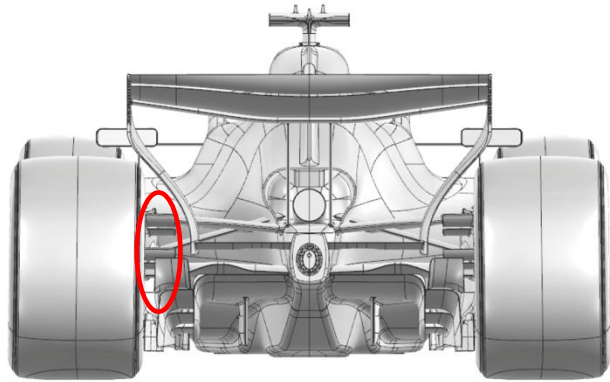



# FIA FORMULA 1 WORLD CHAMPIONSHIP



## Car Presentation – British Grand Prix Williams

	Updated component	Primary reason for update	Geometric differences compared to previous version	Brief description on how the update works (min 20, max 100 words)
1	Front Wing	Performance – Flow Conditioning	A new front wing geometry with updated profiles and endplate surfaces.	An updated front wing assembly has been developed, which aims to generate an increase in local loading combined with an improved flow field interaction with downstream components.



# FIA FORMULA 1 WORLD CHAMPIONSHIP

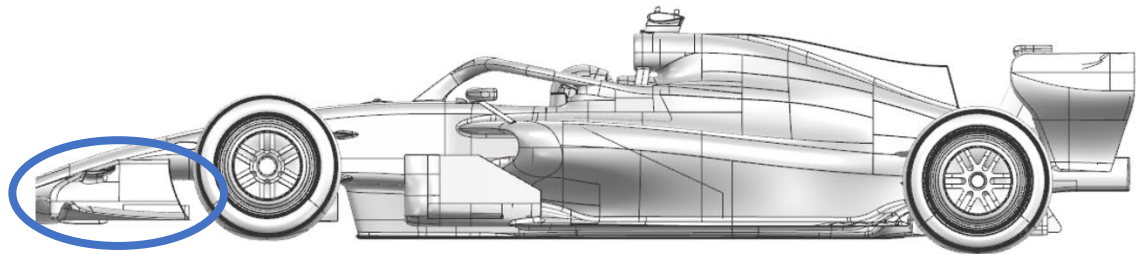
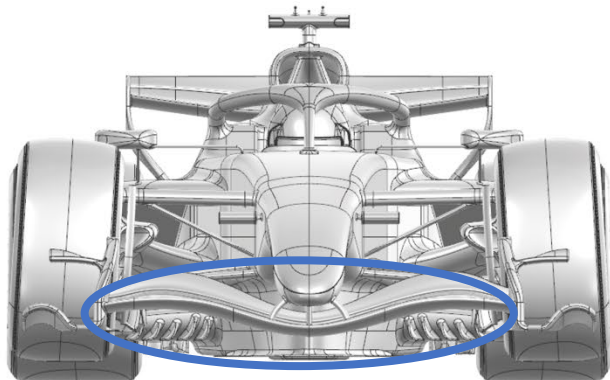
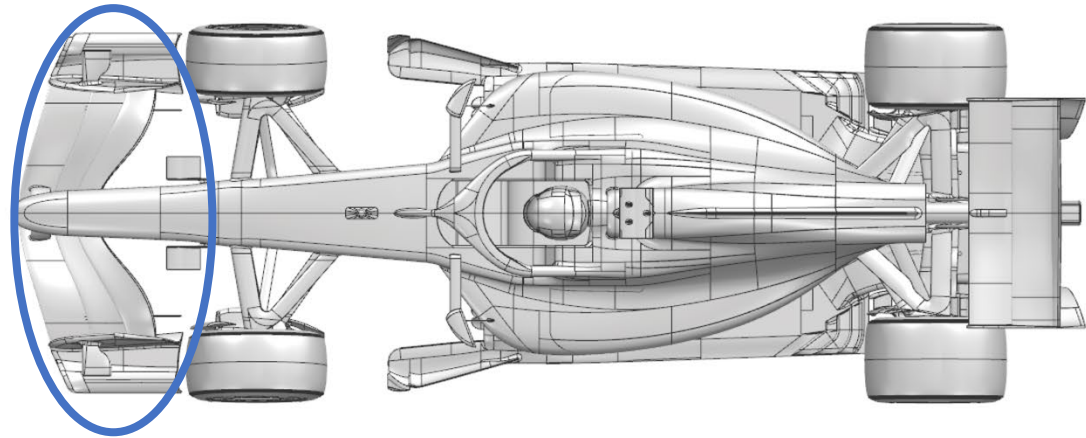
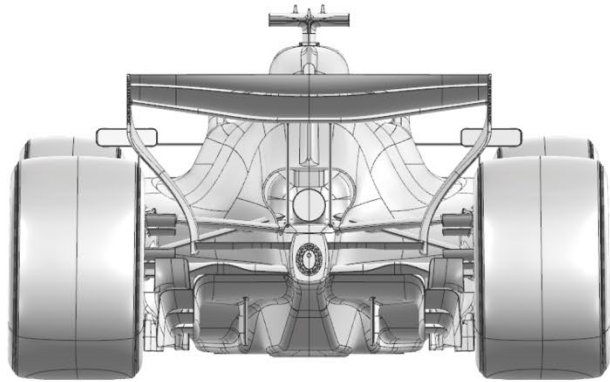



# FIA FORMULA 1 WORLD CHAMPIONSHIP



## Car Presentation – British Grand Prix Visa Cash App Racing Bulls

	Updated component	Primary reason for update	Geometric differences compared to previous version	Brief description on how the update works (min 20, max 100 words)
1	Floor Edge & Diffuser	Performance – Local Load	Updated floor corner & diffuser geometry	The combined updates optimise the flow around the rear floor, allowing it to generate more load and provide increased performance.
2	Rear Corner	Performance – Flow Conditioning	New forward deflector geometry	In combination with the above, the new deflector targets an improvement in local flow conditioning and improved floor performance.



# FIA FORMULA 1 WORLD CHAMPIONSHIP

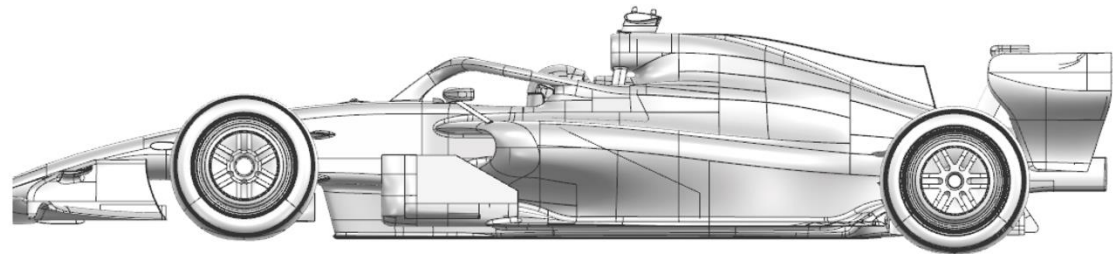
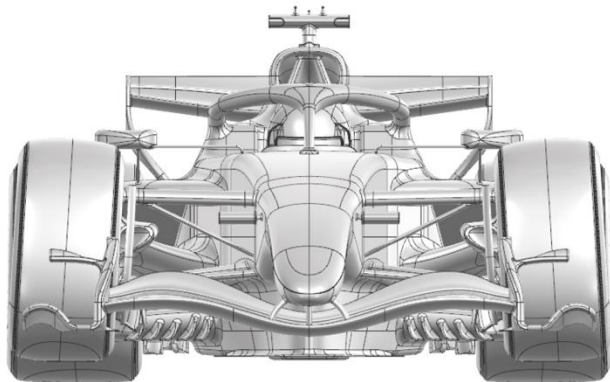
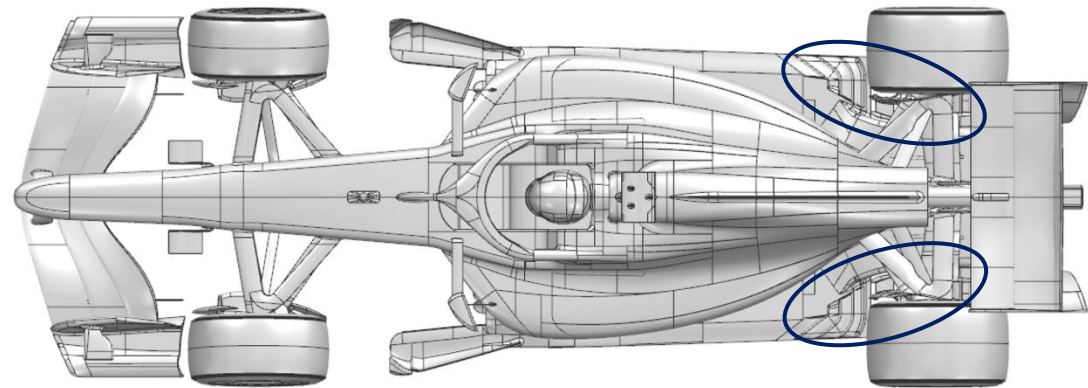
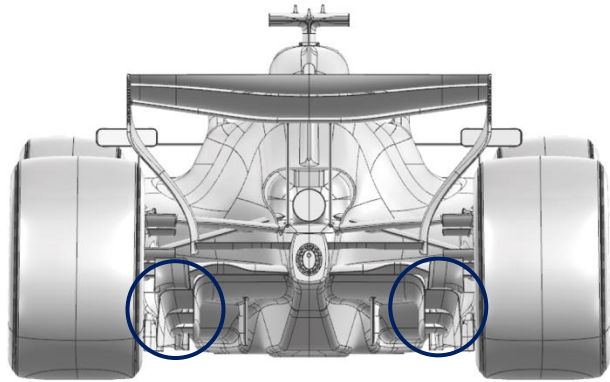



FIA FORMULA 1 WORLD CHAMPIONSHIP



**Car Presentation – British Grand Prix  
Aston Martin Aramco F1 Team**

No updates submitted for this event.



# FIA FORMULA 1 WORLD CHAMPIONSHIP



## Car Presentation – British Grand Prix

### \*TGR HAAS F1 TEAM\*

	Updated component	Primary reason for update	Geometric differences compared to previous version	Brief description on how the update works (min 20, max 100 words)
1	Rear Wing	Performance - Local Load	New Rear Wing profiles	The rear wing profiles were comprehensively revised, with particular emphasis placed on the optimisation of flap geometry, leading to an increase in aerodynamic load while preserving a high level of overall efficiency across the operating range.
2	Rear Wing Endplate	Performance - Flow Conditioning	Rear Wing Endplate with external protrusions	The Rear Wing Endplates were refined through the introduction of localized protrusions aimed at promoting upwash, contributing to the increase of load of this assembly.



# FIA FORMULA 1 WORLD CHAMPIONSHIP

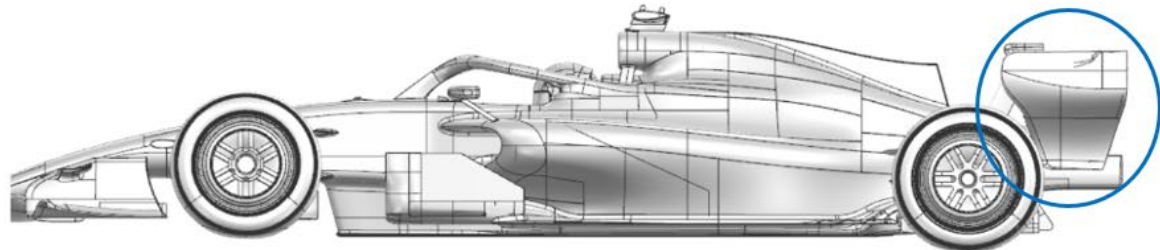
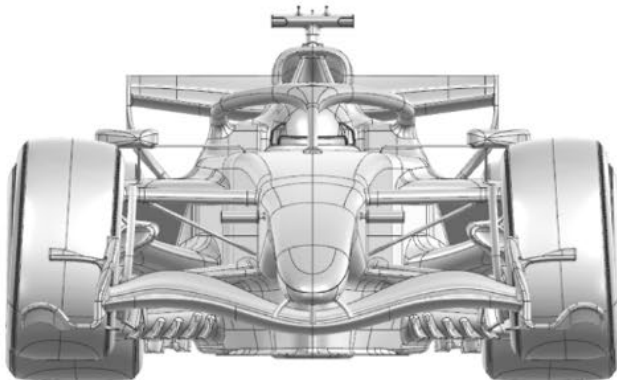
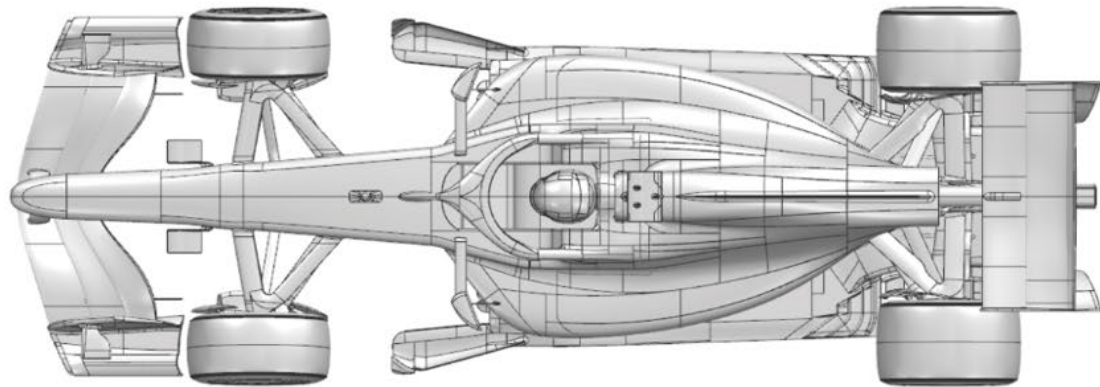
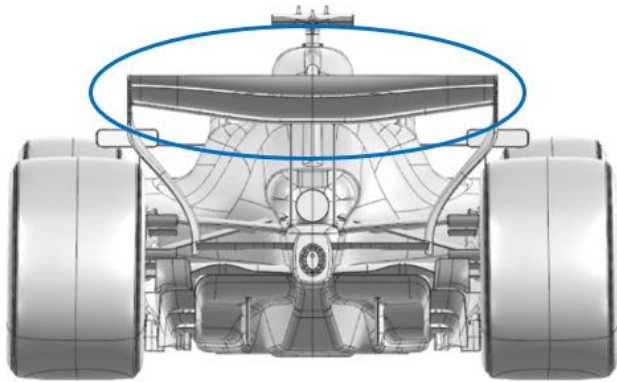



FIA FORMULA 1 WORLD CHAMPIONSHIP



**Car Presentation – British Grand Prix  
Audi Revolut F1 Team**

No updates submitted for this event.



FIA FORMULA 1 WORLD CHAMPIONSHIP



**Car Presentation – British Grand Prix  
BWT Alpine F1 Team**

No updates submitted for this event.



FIA FORMULA 1 WORLD CHAMPIONSHIP



**Car Presentation – British Grand Prix  
Cadillac**

**No Updates**