



FIA FORMULA 1 WORLD CHAMPIONSHIP



2026 BARCELONA-CATALUNYA GRAND PRIX

12 - 14 June 2026

From	The FIA Formula 1 Media Delegate	Document	14
To	All Teams, All Officials	Date	12 June 2026
		Time	10:57

Title Car Presentation Submissions

Description Car Presentation Submissions

Enclosed 2026 Barcelona-Catalunya Grand Prix - Car Presentation Submissions.pdf

Roman De Lauw

The FIA Formula 1 Media Delegate



FIA FORMULA 1 WORLD CHAMPIONSHIP



Car Presentation – Spanish Grand Prix McLaren Mastercard F1 Team

	Updated component	Primary reason for update	Geometric differences compared to previous version	Brief description on how the update works (min 20, max 100 words)
1	Front Wing	Performance - Flow Conditioning	Revised Front Wing Endplate	The front wing endplate has been modified, resulting in an improvement of aerodynamic flow conditioning and subsequently enhanced aerodynamic overall performance.



FIA FORMULA 1 WORLD CHAMPIONSHIP

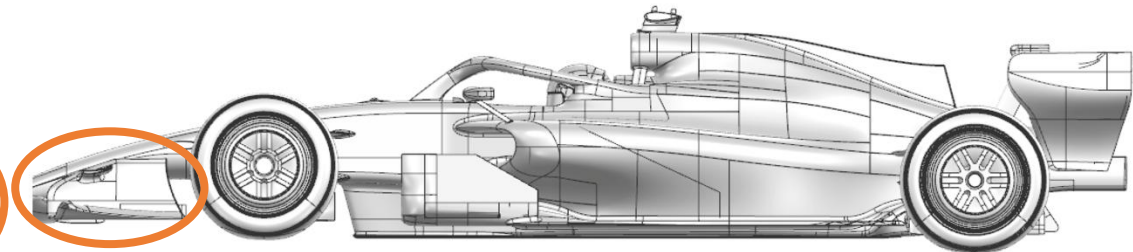
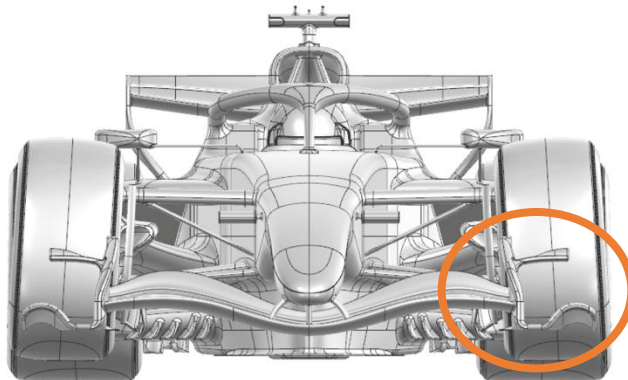
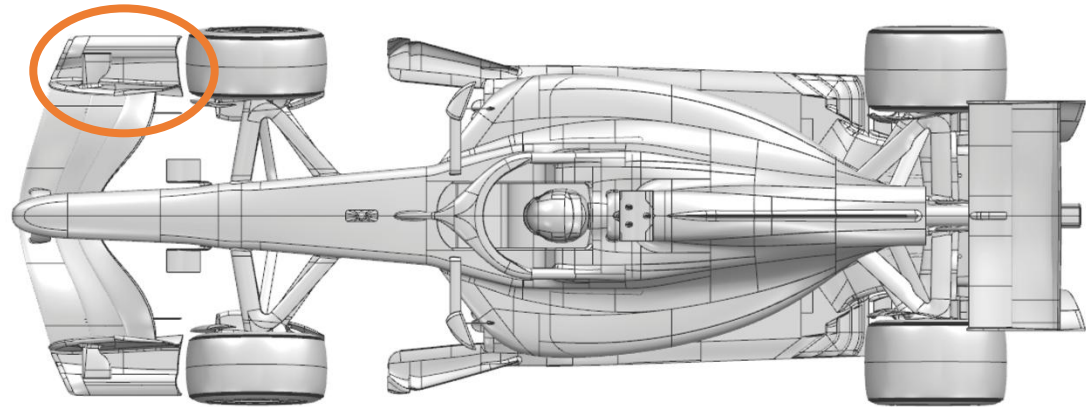
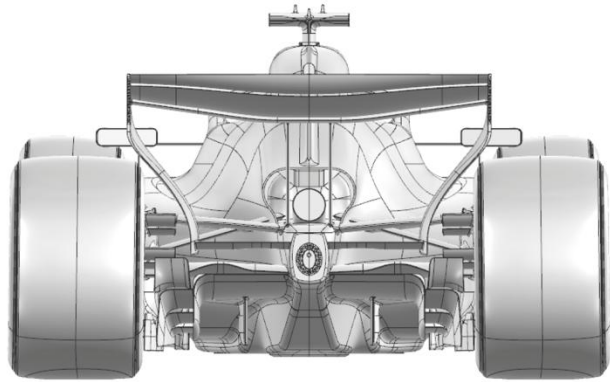



FIA FORMULA 1 WORLD CHAMPIONSHIP



Car Presentation – 2026 Barcelona-Catalunya Grand Prix

Mercedes-AMG PETRONAS F1 Team

	Updated component	Primary reason for update	Geometric differences compared to previous version	Brief description on how the update works (min 20, max 100 words)
1	Rear Wing	Performance - Local Load	Small winglets added on centreline to rear wing.	These winglets increase the camber of the upper rear wing on centreline, generating downforce and drag at a ratio attractive for this event.



FIA FORMULA 1 WORLD CHAMPIONSHIP

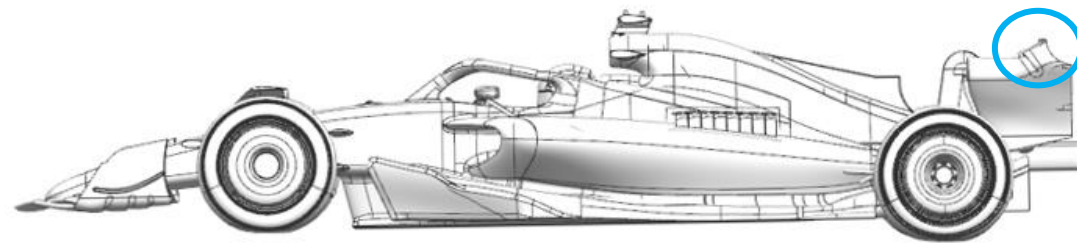
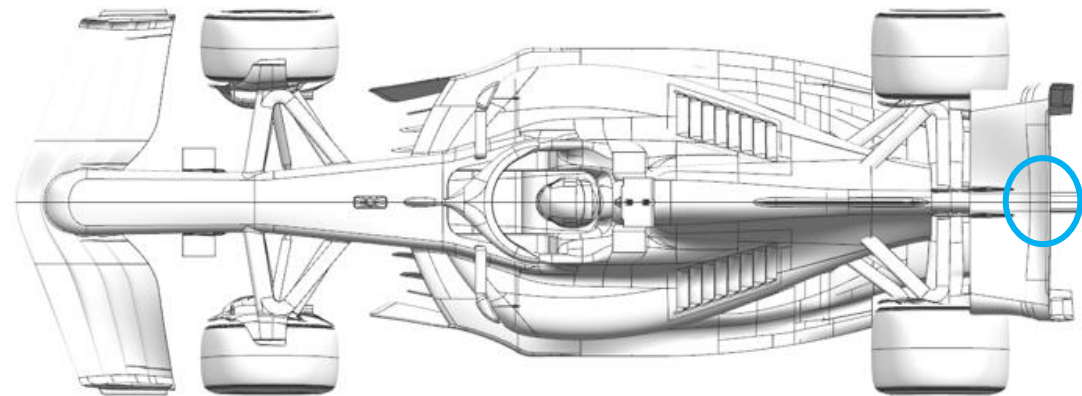
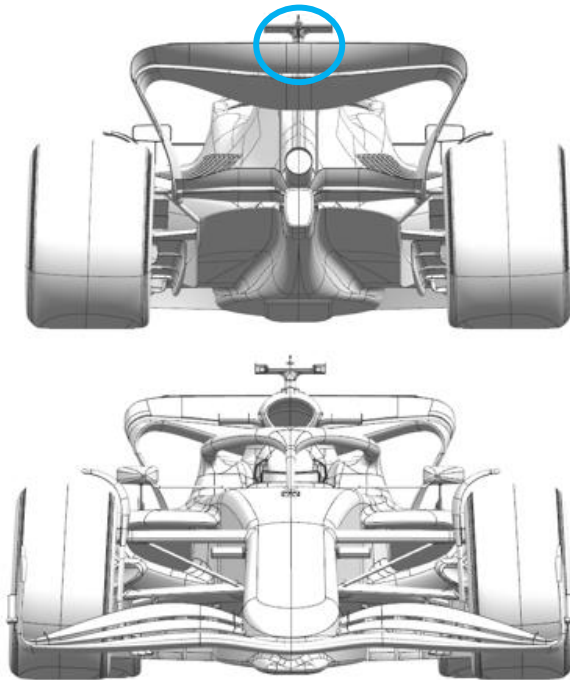



FIA FORMULA 1 WORLD CHAMPIONSHIP



Car Presentation – Barcelona Grand Prix Oracle Red Bull Racing.

	Updated component	Primary reason for update	Geometric differences compared to previous version	Brief description on how the update works (min 20, max 100 words)
1	Front Wing	Local load and flow conditioning.	The wing element geometries have been revised where these meet the endplate	Achieved by modifying existing parts, a new geometry of the elements near the end plate becomes available. Aim being to improve the local load whilst maintaining flow stability.
2	Front wing	Balance range	Camber increase of the front wing flaps.	Should the front wing load demand exceed expectations, a more cambered flap assembly has been produced to offer more local load.
3				
4				



FIA FORMULA 1 WORLD CHAMPIONSHIP

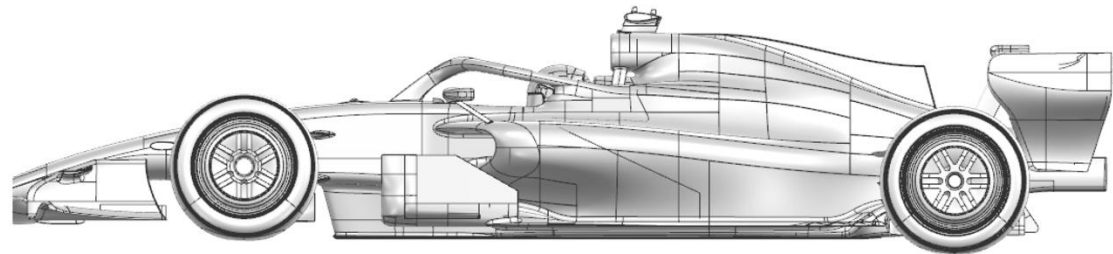
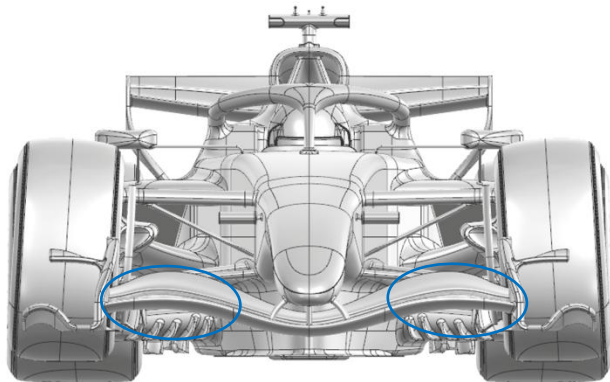
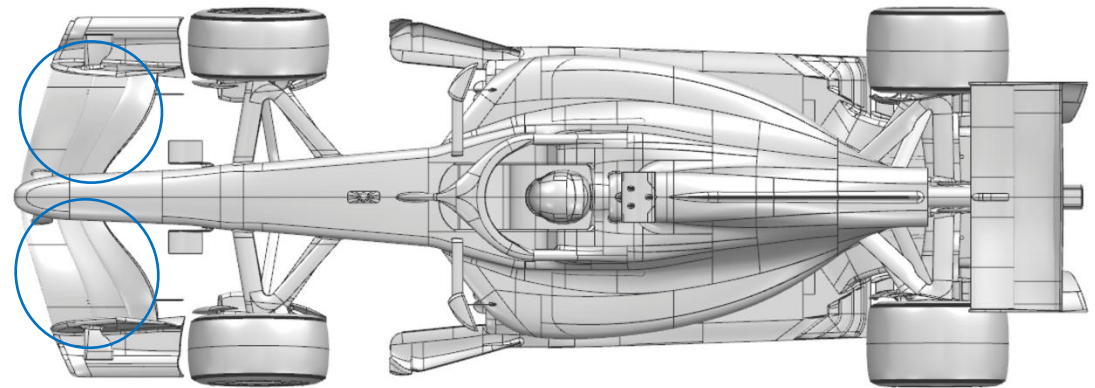
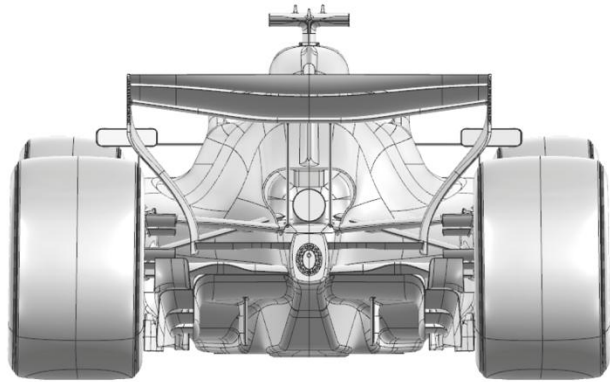



FIA FORMULA 1 WORLD CHAMPIONSHIP



Car Presentation – Barcelona-Catalunya Grand Prix SCUDERIA FERRARI HP

	Updated component	Primary reason for update	Geometric differences compared to previous version	Brief description on how the update works (min 20, max 100 words)
1	Front Wing	Performance - Local Load	Revised front wing footplate with new vanes arrangement and endplate diveplane addition, optimized wing elements spanwise loading distribution. New SM mechanism links and integration in the nose, revised nose shape with raised lower surface	Evolution of the front wing platform raced so far, with enhanced tip flow features coming with front wheel wake control benefits as well as increased aero balance capacity. More integrated SM mechanism links returns tidier centre line flow features. It also comes with flap lips modulation.
2	Front Wing Endplate			
3	Nose			
4	Floor Body	Performance - Local Load	Reduced keel volume. Redesigned front floor leading edge profiles and claws, front floor board elements optimisation (horizontal and vertical ones). Optimisation of rearward floor corner winglets, reprofiling of diffuser sidewall cutout. Updated diffuser winglet angle of attack and diffuser / tail expansion profile	Benefiting from an improved onset flow quality, this entire floor update is targeting overall aerodynamic load increase across the main car operating window as well as flow features robustness improvements together with improved flow topology and energy towards the rear corners
5	Floor Board			
6	Floor Edge			
7	Diffuser			
8	Sidepod/Coke	Performance - Flow Conditioning	Inflated sidepod shoulder and adapted cokeline	This geometry has been developed in conjunction with the floor update and manipulates front wheel wake together with the floor board update, as well as the rebalancing the front floor pressurisation



FIA FORMULA 1 WORLD CHAMPIONSHIP

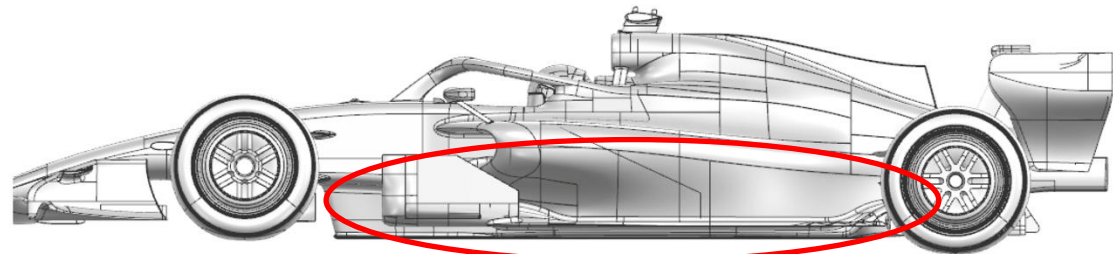
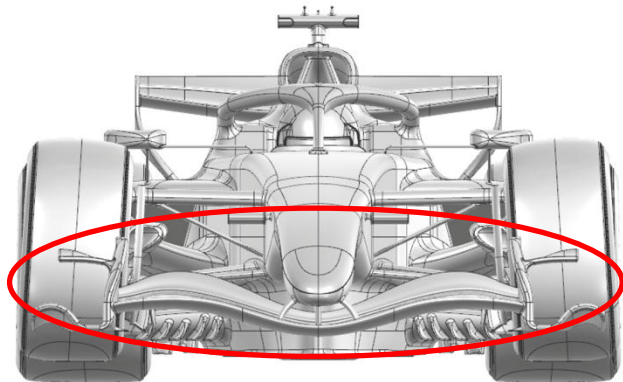
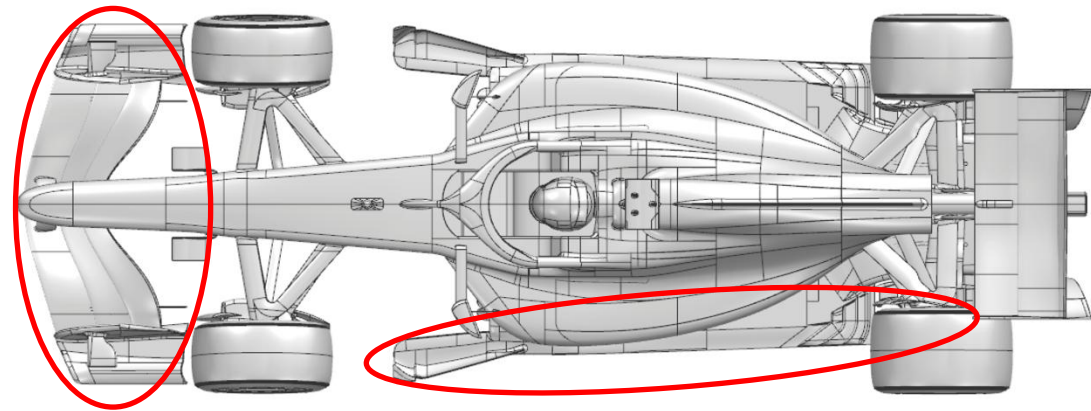
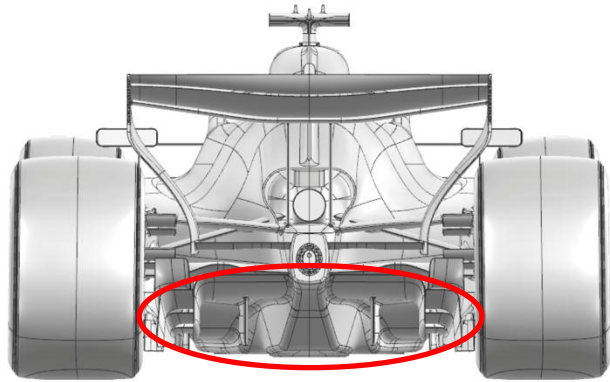



FIA FORMULA 1 WORLD CHAMPIONSHIP



Car Presentation – Barcelona-Catalunya Grand Prix

Williams

	Updated component	Primary reason for update	Geometric differences compared to previous version	Brief description on how the update works (min 20, max 100 words)
1	Rear Wing	Performance – Local Load	SM Fairing Winglets and Third Element local extensions	Different SM fairing geometry with added winglets offering local load for high downforce tracks. Local trailing edge extensions added on the rear wing third element for efficient load increase.



FIA FORMULA 1 WORLD CHAMPIONSHIP

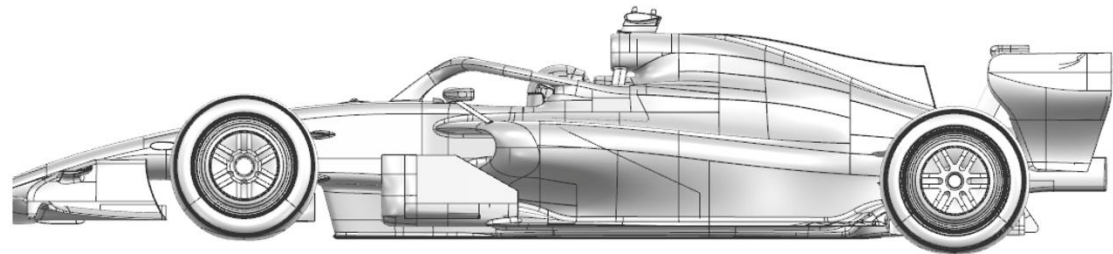
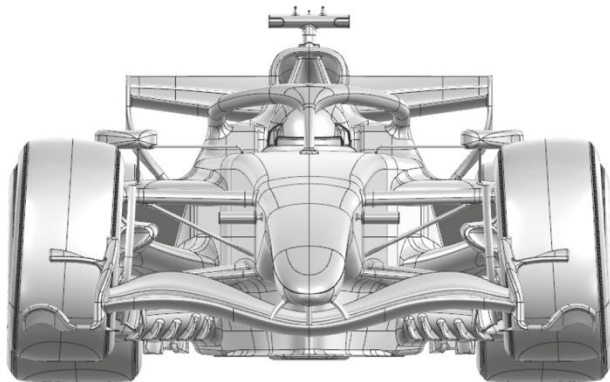
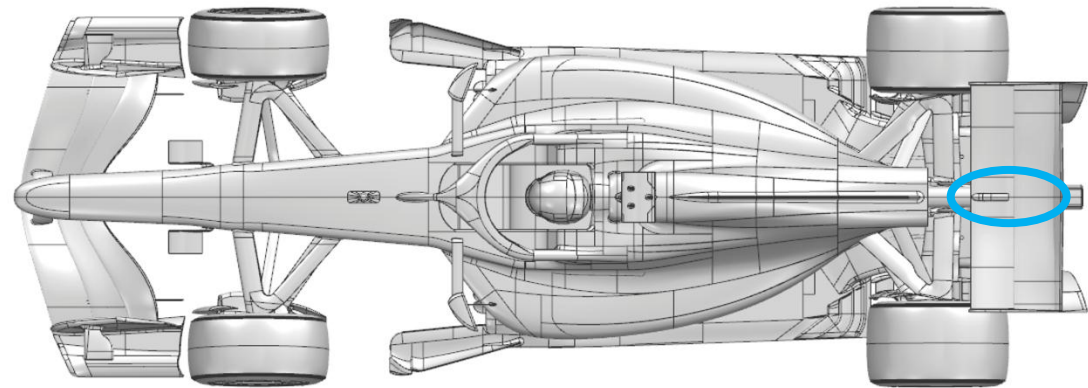
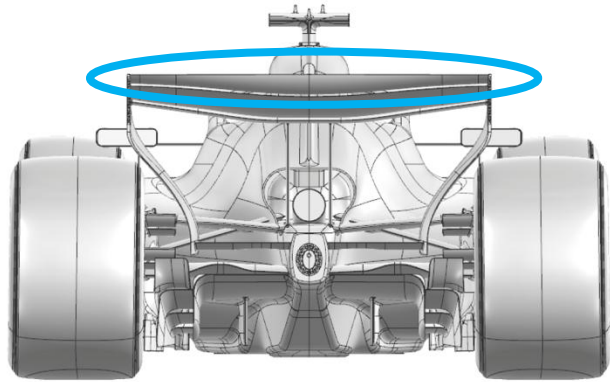



FIA FORMULA 1 WORLD CHAMPIONSHIP



Car Presentation – Monaco Grand Prix Visa Cash App Racing Bulls

	Updated component	Primary reason for update	Geometric differences compared to previous version	Brief description on how the update works (min 20, max 100 words)
1	Front Wing	Circuit specific - Balance Range	Extra flap gurney options available	Additional front wing load is generated by adding Gurney flaps to the trailing edge. This provides extended balance range for the car for setup optimisation during the weekend.
2	Diffuser / Rear Crash Structure	Performance – Flow Conditioning	Updated diffuser profile & integration with rear crash structure	Provides improved aerodynamic flow conditioning at the back of the car, to aid with efficient load generation from the floor.



FIA FORMULA 1 WORLD CHAMPIONSHIP

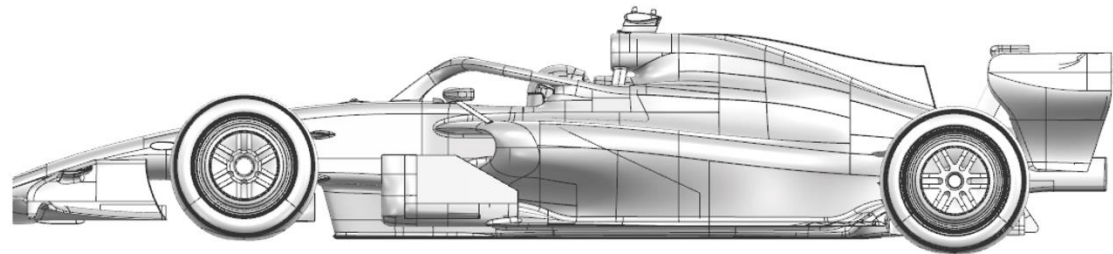
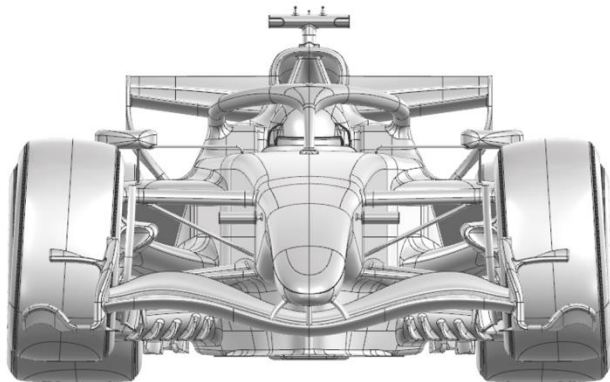
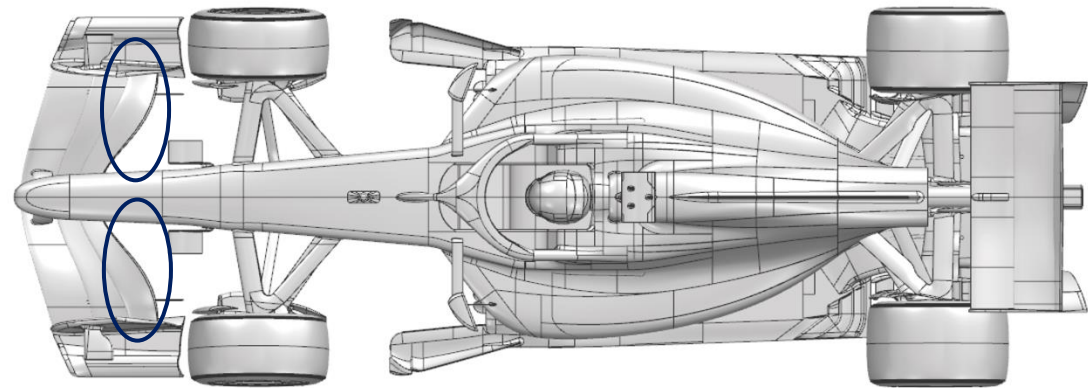
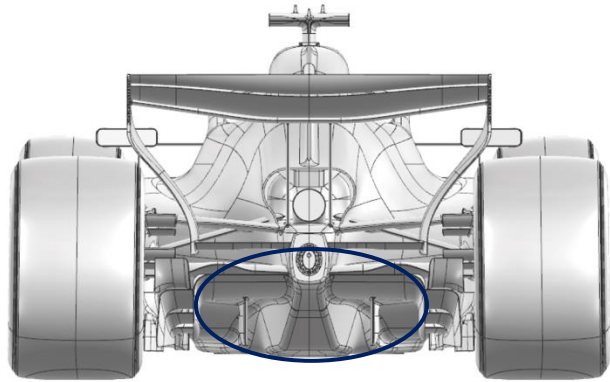



FIA FORMULA 1 WORLD CHAMPIONSHIP



**Car Presentation – Barcelona-Catalunya Grand Prix
Aston Martin Aramco F1 Team**

No updates submitted for this event.



FIA FORMULA 1 WORLD CHAMPIONSHIP



Car Presentation – Barcelona Grand Prix

TGR HAAS F1 Team

	Updated component	Primary reason for update	Geometric differences compared to previous version	Brief description on how the update works (min 20, max 100 words)
1	Rear Impact Structure	Performance – Local Load	Simplified Rear Impact Structure geometry	An alternative Rear Impact Structure device will be available on track, enabling targeted tuning of the car's characteristics for this circuit.



FIA FORMULA 1 WORLD CHAMPIONSHIP

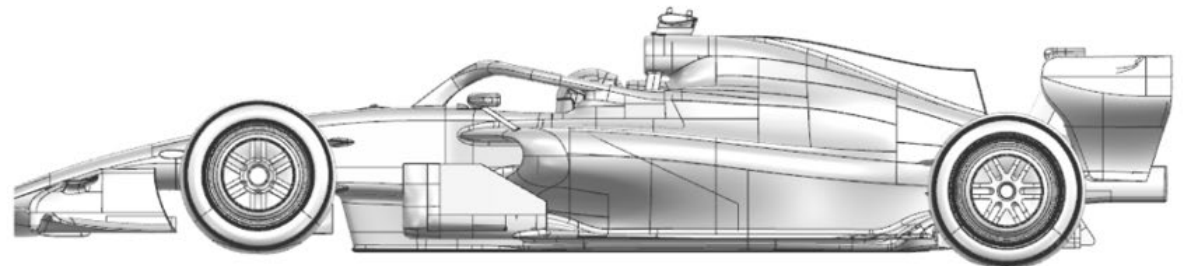
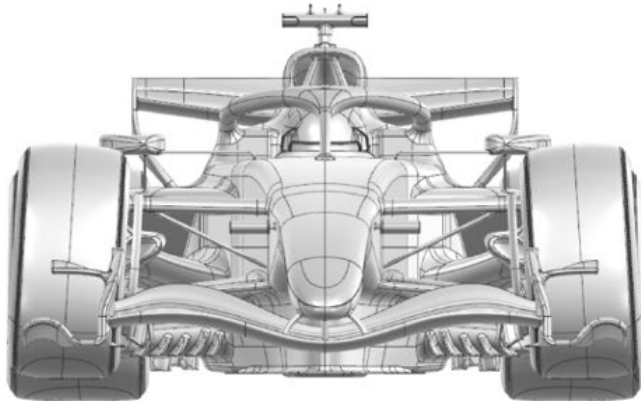
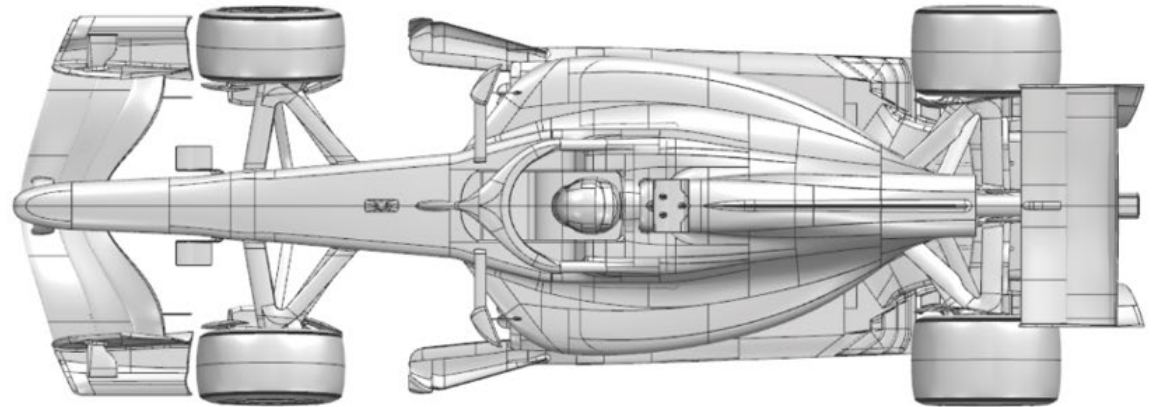
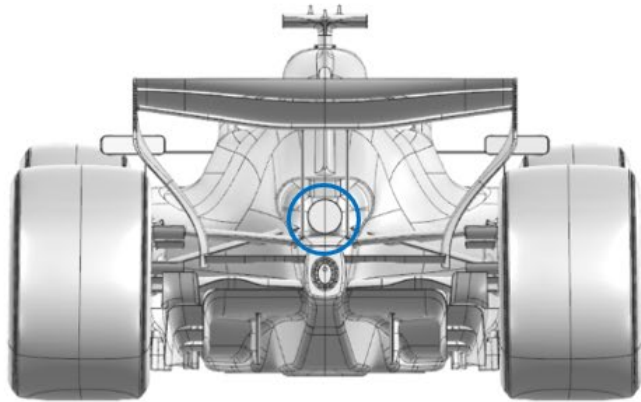



FIA FORMULA 1 WORLD CHAMPIONSHIP



**Car Presentation – Barcelona-Catalunya Grand Prix
Audi Revolut F1 Team**

No updates submitted for this event.



FIA FORMULA 1 WORLD CHAMPIONSHIP



**Car Presentation – Barcelona-Catalunya Grand Prix
BWT Alpine F1 Team**

No updates submitted for this event.



FIA FORMULA 1 WORLD CHAMPIONSHIP



Car Presentation – Barcelona Grand Prix Cadillac

	Updated component	Primary reason for update	Geometric differences compared to previous version	Brief description on how the update works (min 20, max 100 words)
1	Cooling Louvres	Performance – Cooling Range	Addition of cooling louvres to upper surface of rear Sidepod	The addition of louvres to the upper surface of the rear sidepod has been implemented to increase the power unit cooling range
2	Rear Wing	Performance – Drag Reduction	Addition of SLM actuator fairing	Reintroduction of an SLM mechanism fairing to the updated Rear Wing that was first introduced at the previous event, to re-instate the availability of low drag mode on this wing



FIA FORMULA 1 WORLD CHAMPIONSHIP

