

TO: Teams Manufacturers

CATEGORY: Hypercar LMP2 LMGTE Pro LMGTE Am

DECISION N°: WEC_2021_D0039_LMGTE_BOP_BAHR_Amended

DATE: 28/10/2021 **FROM:** The WEC Committee

SUBJECT: BOP for LMGTE for Bahrain Competition

APPLICABLE REGULATION

Article 6.3.2 2021 FIA World Endurance Championship Sporting Regulations

DECISION

In application of Article 6.3.2 of the 2021 FIA WEC Sporting Regulations, please find below: the LMGTE BOP table.

PERIOD OF VALIDITY/APPLICATION OF THE DECISION

This decision comes into effect:

- with immediate application**
 from:

And is applicable:

- until further notice**
 for the mentioned Competition(s) only

LMGTE PRO

FERRARI - 488 GTE EVO	prev. (1)	adjust. (2)	final
MINIMUM CAR WEIGHT (kg) (*)	1255 kg	-	1255 kg
MAXIMUM ONBOARD FUEL VOLUME (liter)	93 l.	-4 l.	89 l.
DECLARED MINIMUM LAMBDA			1,10
Engine power - Pboost ratio max vs RPM			
4000	1,81	-0,08	1,73
4500	1,78	-0,08	1,70
5000	1,79	-0,08	1,71
5500	1,78	-0,08	1,70
6000	1,71	-0,08	1,63
6500	1,62	-0,08	1,54
7000	1,50	-0,08	1,42
7100	1,10	-	1,10

CORVETTE C8.R	prev. (1)	adjust. (2)	final
MINIMUM CAR WEIGHT (kg) (*)	1235 kg	-	1235 kg
MAXIMUM ONBOARD FUEL VOLUME (liter)	98 l.	-	98 l.
DECLARED MINIMUM LAMBDA			0,88
Engine power - Air restrictor diameter			
1 x MAXIMUM RESTRICTOR DIAMETER (mm)	43,5 mm		43,5 mm

Notes:
Adjustments are made with:
 - the waivers required;
 - with the data provided by the manufacturers;
 - with the information provided by the manufacturers;
 - with analysis made by FIA/ACO.

PORSCHE 911 RSR - 19	prev. (1)	adjust. (2)	final
MINIMUM CAR WEIGHT (kg) (*)			1264 kg
MAXIMUM ONBOARD FUEL VOLUME (liter)	99 l.	-	99 l.
DECLARED MINIMUM LAMBDA			0,89
Engine power - Air restrictor diameter			
2 x MAXIMUM RESTRICTOR DIAMETER (mm)	30,8 mm		30,8 mm

(*) : weight including camera (or dummy) equipment
 (1): the previous value is referring to the previous BOP
 (2): the adjustments are related to the changes done for this BOP

LMGTE AM

FERRARI - 488 GTE EVO	prev. (1)	adjust. (2)	final
MAXIMUM ONBOARD FUEL VOLUME (liter)	90 l.	-4 l.	86 l.
DECLARED MINIMUM LAMBDA			1,10
Engine power - Pboost ratio max vs RPM		Pboost ratio Max (-)	
4000	1,77	-0,08	1,69
4500	1,74	-0,08	1,66
5000	1,75	-0,08	1,67
5500	1,74	-0,08	1,66
6000	1,67	-0,08	1,59
6500	1,58	-0,08	1,50
7000	1,46	-0,08	1,38
7100	1,06	-	1,06

ASTON MARTIN VANTAGE AMR	prev. (1)	adjust. (2)	final
MAXIMUM ONBOARD FUEL VOLUME (liter)	93 l.	-2 l.	91 l.
DECLARED MINIMUM LAMBDA			0,94
Engine power - Pboost ratio max vs RPM		Pboost ratio Max (-)	
4000	1,48	-0,04	1,44
4500	1,53	-0,04	1,49
5000	1,53	-0,04	1,49
5500	1,54	-0,04	1,50
6000	1,54	-0,04	1,50
6500	1,49	-0,04	1,45
7000	1,40	-0,04	1,36
7200	1,37	-0,04	1,33
7300	1,20	-	1,20

PORSCHE 911 RSR - 19	prev. (1)	adjust. (2)	final
MAXIMUM ONBOARD FUEL VOLUME (liter)	96 l.	-	96 l.
DECLARED MINIMUM LAMBDA			0,89
Engine power - Air restrictor diameter		Pboost ratio Max (-)	
2 x MAXIMUM RESTRICTOR DIAMETER (mm)	30,3 mm		30,3 mm

Notes:
Adjustments are made with:
 - the waivers required;
 - with the data provided by the manufacturers;
 - with the information provided by the manufacturers;
 - with analysis made by FIA/ACO.

(*) : weight including camera (or dummy) equipment
 (1): the previous value is referring to the previous BOP
 (2): the adjustments are related to the changes done for this BOP
 (**): for tyre safety boundaries

COMPETITOR NAME	MINIMUM				Fixed (Art 6.3.4)	offset (**)	final
	Initial	SB (race-1)	SB (race-2)	SB (champ.)			
TF SPORT - #33	1247	10		10			1267
TEAM PROJECT 1 - #46	1269						1269
CETILAR RACING - #47	1270			5			1275
AF CORSE - #54	1270						1270
TEAM PROJECT 1 - #56	1269						1269
KESSEL RACING - #57	1270				15		1285
IRON LYNX - #60	1270	5					1275
DEMPSEY-PROTON RACING - #77	1269						1269
AF CORSE - #83	1270	15	15	15			1315
IRON LYNX - #85	1270						1270
GR RACING - #86	1269						1269
DEMPSEY-PROTON RACING - #88	1269						1269
ASTON MARTIN RACING - #98	1247		10				1257
D'STATION RACING - #777	1247		5				1252

Maximum Boost Pressure Control Strategy

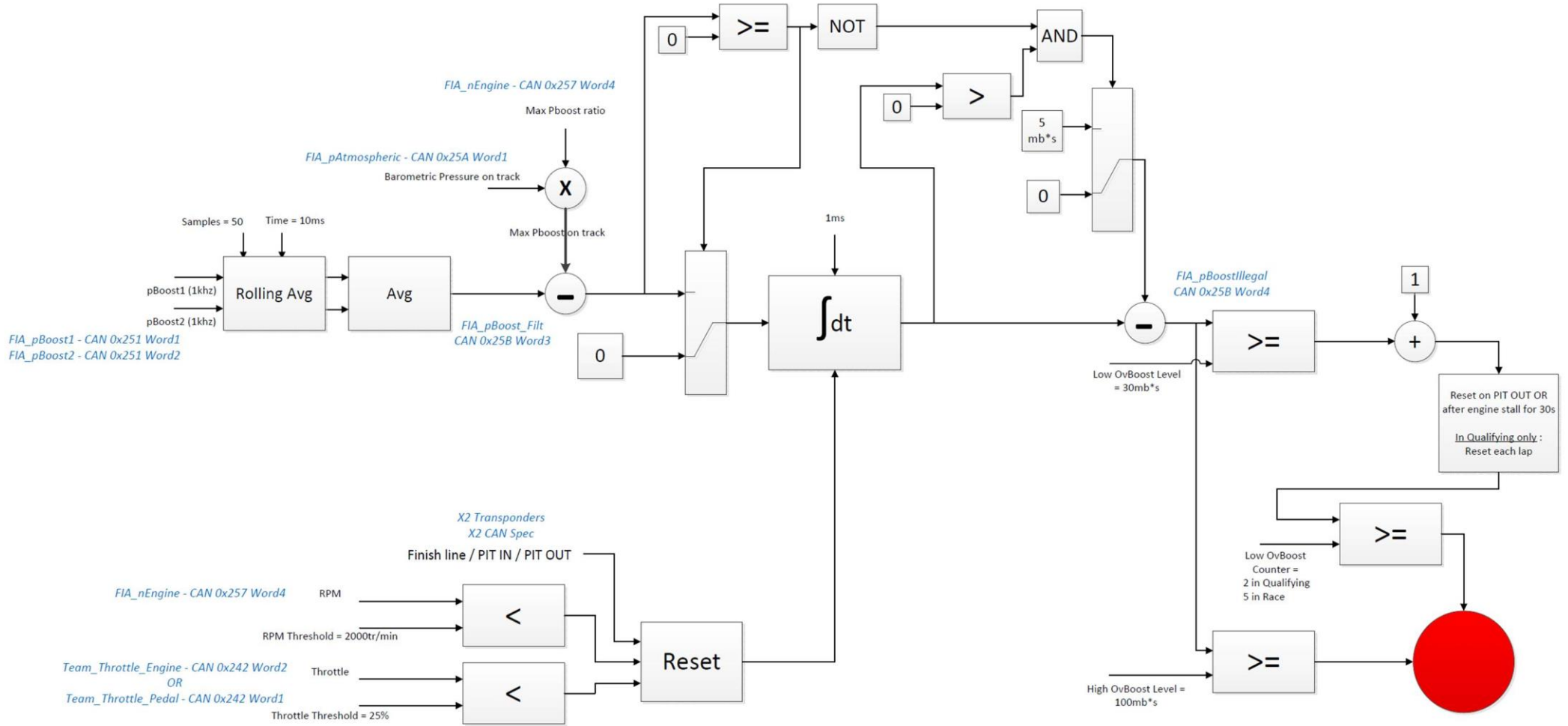

Any decision taken by the WEC Committee is not subject to appeal.

<http://fiawec.alkamelsystems.com/noticeBoard.html>