

TO: Teams Manufacturers

CATEGORY: Hypercar LMP2 LMGTE Pro LMGTE Am

DECISION N°: WEC_2021_D0027_LMGTE_BOP_SPA

DATE: 23/04/2021 **FROM:** The WEC Committee

SUBJECT: BOP for LMGTE for SPA

APPLICABLE REGULATION

Article 6.3.2 2021 FIA World Endurance Championship Sporting Regulations

DECISION

In application of Article 6.3.2 of the 2021 FIA World Endurance Championship Sporting Regulations, please find below: the LMGTE Pro BOP table and the LMGTE Am BOP & success ballast tables.

PERIOD OF VALIDITY/APPLICATION OF THE DECISION

This decision comes into effect:

- with immediate application**
 from:

And is applicable:

- until further notice**
 for the mentioned Competition(s) only

LMGT PRO

FERRARI - 488 GTE EVO	prev. (1)	adjust. (2)	final
MINIMUM CAR WEIGHT (kg) (*)	1260 kg	-	1260 kg
MAXIMUM ONBOARD FUEL VOLUME (liter)	93 l.	-	93 l.
DECLARED MINIMUM LAMBDA			1,10
Engine power - Pboost ratio max vs RPM			
4000	1,81	-	1,81
4500	1,78	-	1,78
5000	1,79	-	1,79
5500	1,78	-	1,78
6000	1,71	-	1,71
6500	1,62	-	1,62
7000	1,50	-	1,50
7100	1,10	-	1,10

CORVETTE C8.R	prev. (1)	adjust. (2)	final
MINIMUM CAR WEIGHT (kg) (*)	1235 kg	-	1235 kg
MAXIMUM ONBOARD FUEL VOLUME (liter)	103 l.	-	103 l.
DECLARED MINIMUM LAMBDA			0,88
Engine power - Air restrictor diameter			
2 x MAXIMUM RESTRICTOR DIAMETER (mm)	43,5 mm	-	43,5 mm

PORSCHE 911 RSR - 19	prev. (1)	adjust. (2)	final
MINIMUM CAR WEIGHT (kg) (*)	1259 kg	-	1259 kg
MAXIMUM ONBOARD FUEL VOLUME (liter)	99 l.	-	99 l.
DECLARED MINIMUM LAMBDA			0,89
Engine power - Air restrictor diameter			
2 x MAXIMUM RESTRICTOR DIAMETER (mm)	30,8 mm	-	30,8 mm

Notes:

- Adjustments are made with:*
- the waivers required;
 - with the data provided by the manufacturers;
 - with the information provided by the manufacturers;
 - with analysis made by FIA/ACO.

(*): weight including camera (or dummy) equipment

- (1): the previous value is referring to the previous BOP
 (2): the adjustments are related to the changes done for this BOP

LMGT AM

FERRARI - 488 GTE EVO	prev. (1)	adjust. (2)	final
MAXIMUM ONBOARD FUEL VOLUME (liter)	93 l.	-	90 l.
DECLARED MINIMUM LAMBDA			1,10
Engine power - Pboost ratio max vs RPM			
	Pboost ratio Max (-)		
4000	1,77	-	1,77
4500	1,74	-	1,74
5000	1,75	-	1,75
5500	1,74	-	1,74
6000	1,67	-	1,67
6500	1,58	-	1,58
7000	1,46	-	1,46
7100	1,06	-	1,06

ASTON MARTIN VANTAGE AMR	prev. (1)	adjust. (2)	final
MAXIMUM ONBOARD FUEL VOLUME (liter)	93 l.	-	93 l.
DECLARED MINIMUM LAMBDA			0,94
Engine power - Pboost ratio max vs RPM			
	Pboost ratio Max (-)		
4000	1,48	-	1,48
4500	1,53	-	1,53
5000	1,53	-	1,53
5500	1,54	-	1,54
6000	1,54	-	1,54
6500	1,49	-	1,49
7000	1,40	-	1,40
7200	1,37	-	1,37
7300	1,20	-	1,20

PORSCHE 911 RSR - 19	prev. (1)	adjust. (2)	final
MAXIMUM ONBOARD FUEL VOLUME (liter)	96 l.	-	96 l.
DECLARED MINIMUM LAMBDA			0,89
Engine power - Air restrictor diameter			
2 x MAXIMUM RESTRICTOR DIAMETER (mm)	30,3 mm	-	30,3 mm

Notes:

- Adjustments are made with:*
- the waivers required;
 - with the data provided by the manufacturers;
 - with the information provided by the manufacturers;
 - with analysis made by FIA/ACO.

(*): weight including camera (or dummy) equipment

- (1): the previous value is referring to the previous BOP
 (2): the adjustments are related to the changes done for this BOP

(**): for tyre safety boundaries

COMPETITOR NAME	N°	MINIMUM CAR WEIGHT (kg) (*)					
		initial	SB (race-1)	(race)	SB (champ.)	offset (**)	final
TF SPORT	33	1247					1247
TEAM PROJECT 1	46	1269					1269
CETILAR RACING	47	1270					1270
AF CORSE	54	1270					1270
TEAM PROJECT 1	56	1269					1269
IRON LYNX	60	1270					1270
DEMPSEY-PROTON RACING	77	1269				0	1269
AF CORSE	83	1270					1270
IRON LYNX	85	1270					1270
GR RACING	86	1269					1269
DEMPSEY-PROTON RACING	88	1269					1269
ASTON MARTIN RACING	98	1247					1247
D'STATION RACING	777	1247					1247

Any decision taken by the WEC Committee is not subject to appeal.

<http://fiawec.alkamelsystems.com/noticeBoard.html>

Maximum Boost Pressure Control Strategy

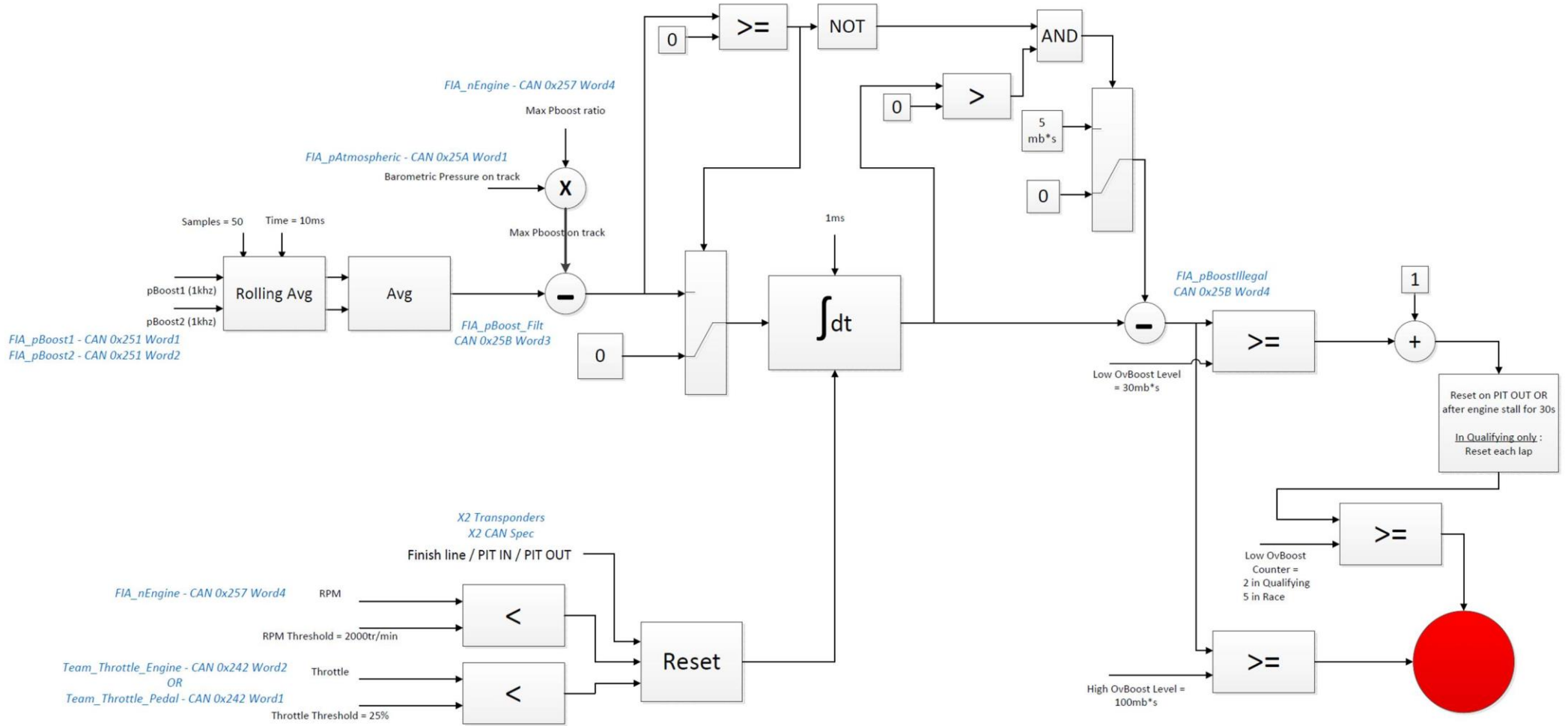

Any decision taken by the WEC Committee is not subject to appeal.

<http://fiawec.alkamelsystems.com/noticeBoard.html>