



2021

Le Mans Hypercar Technical Regulations
(SUBJECT TO WMSC APPROVAL)



Work in Progress

Possibly be deleted

ARTICLE 0: FOREWORD

ARTICLE 1: DEFINITIONS

- 1.1 "LE MANS HYPERCAR" – HYPERCAR
- 1.2 Automobile
- 1.3 Land vehicle
- 1.4 Bodywork
- 1.5 Wheel centre line
- 1.6 Height measurements
- 1.7 Distances
- 1.8 Wheel
- 1.9 Complete wheel
- 1.10 Automobile make
- 1.11 Event
- 1.12 Weight
- 1.13 Engine cubic capacity
- 1.14 Pressure charging
- 1.15 Cockpit
- 1.16 Sprung suspension
- 1.17 Survival cell
- 1.18 Camera
- 1.19 Camera housing
- 1.20 Cockpit padding
- 1.21 Brake calliper
- 1.22 Electronically controlled
- 1.23 Closed-loop electronic control system
- 1.24 Front power train
- 1.25 Rear power train
- 1.26 Power unit
- 1.27 Energy Recovery System (ERS)
- 1.28 Motor Generator Unit - Kinetic (MGU-K)
- 1.29 Energy Store (ES)
- 1.30 ES cells
- 1.31 DC-DC converter
- 1.32 Engine
- 1.33 Rotary engine
- 1.34 Compressor inlet
- 1.35 Compressor outlet
- 1.36 Combustion chamber
- 1.37 Fuel injector
- 1.38 Auxiliary oil tank
- 1.39 High pressure fuel pump
- 1.40 Fuel Flow Meter (FFM)
- 1.41 In-cylinder pressure sensor
- 1.42 Supercharger
- 1.43 Ignition coil
- 1.44 Ancillaries
- 1.45 Alternator

- 1.46 Starter motor
- 1.47 Engine inlet
- 1.48 Original car, part and engine
- 1.49 Engine BSFC
- 1.50 Gearbox
- 1.51 Differential
- 1.52 Ride height
- 1.53 Frontal area
- 1.54 Cartesian coordinate system
- 1.55 Stall prevention system

ARTICLE 2: GENERAL PRINCIPLES

- 2.1 Role of the FIA/ACO and basic principles
- 2.2 Amendments to the regulations
- 2.3 Dangerous construction
- 2.4 Compliance with the regulations
- 2.5 Measurements
- 2.6 Duty of Competitor

ARTICLE 3: BODYWORK AND DIMENSIONS

- 3.1 Overall dimensions
- 3.2 Doors
- 3.3 Windscreen and glass areas
- 3.4 Bodywork
- 3.5 Underside of the car
- 3.6 Exhaust pipe outlet
- 3.7 Aerodynamic criteria
- 3.8 Deflection
- 3.9 Bodywork construction
- 3.10 Aerodynamic stability

ARTICLE 4: WEIGHT

- 4.1 Minimum weight
- 4.2 Weight distribution
- 4.3 Ballast
- 4.4 Liquids

ARTICLE 5: POWER UNIT

- 5.1 General
- 5.2 Engine
- 5.3 ERS
- 5.4 Weight and centre of gravity
- 5.5 Power unit torque demand
- 5.6 Power unit control
- 5.7 Engine Fuel systems
- 5.8 Ignition systems
- 5.9 Engine ancillaries
- 5.10 Engine Inlet
- 5.11 Materials and Construction – Definitions
- 5.12 Materials and construction – General
- 5.13 Materials and construction – Components
- 5.14 Materials and construction – Energy recovery, storage systems and electronic systems
- 5.15 Starting the engine
- 5.16 Stall prevention systems operation
- 5.17 Replacing power unit parts

ARTICLE 6: FUEL SYSTEM

- 6.1 Principles
- 6.2 Fuel tanks
- 6.3 Fittings and piping
- 6.4 Fuel tank fillers and breather pipes
- 6.5 Refuelling
- 6.6 Fuel Flow Metering - FFM
- 6.7 Fuel draining and sampling
- 6.8 Fuel per stint

ARTICLE 7: OIL, COOLANT AND HYDRAULIC SYSTEMS AND CHARGE AIR COOLING

- 7.1 Power unit breather fluids
- 7.2 Location of oil tanks
- 7.3 Longitudinal location of oil system
- 7.4 Transversal location of oil system
- 7.5 Coolant header tanks
- 7.6 Cooling systems
- 7.7 Oil and coolant lines
- 7.8 Oil injection
- 7.9 Oil catch tank
- 7.10 Hydraulic systems

ARTICLE 8: ELECTRICAL SYSTEMS

- 8.1 Compliance and safety provisions
- 8.2 Auxiliary circuit and battery
- 8.3 Lighting Equipment
- 8.4 FIA/ACO Logging Requirements
- 8.5 Data acquisition
- 8.6 Telemetry
- 8.7 Track signal information display
- 8.8 Safety Lights

ARTICLE 9: TRANSMISSION SYSTEM

- 9.1 Transmission types
- 9.2 Clutch
- 9.3 Traction control
- 9.4 Clutch disengagement
- 9.5 Gearbox
- 9.6 Gear ratios
- 9.7 Reverse
- 9.8 Gear changing
- 9.9 Torque transfer systems
- 9.10 Differential

ARTICLE 10: SUSPENSION AND STEERING SYSTEMS

- 10.1 Suspension design and geometry
- 10.2 Suspension adjustment
- 10.3 Suspension members
- 10.4 Steering

ARTICLE 11: BRAKE SYSTEM

- 11.1 Brake circuits and pressure distribution
- 11.2 Brake callipers
- 11.3 Brake discs and pads
- 11.4 Brake cooling ducts
- 11.5 Brake pressure modulation
- 11.6 Liquid cooling
- 11.7 Front brake control system

ARTICLE 12: WHEELS AND TYRES

- 12.1 Location
- 12.2 Number of wheels
- 12.3 Complete wheel dimensions
- 12.4 Wheel material
- 12.5 Wheel dimensions
- 12.6 Treatment of tyres
- 12.7 Wheel assembly
- 12.8 Pneumatic jacks
- 12.9 Dimension of tyres

ARTICLE 13: COCKPIT AND SURVIVAL CELL

- 13.1 Principles
- 13.2 Bottom plane of the survival cell
- 13.3 Position of the driver's feet
- 13.4 Position of the steering wheel
- 13.5 Driver's position in relation with the field of visibility
- 13.6 Volumes for the driver and passenger legs – Template H2
- 13.7 Volume for the driver and the passenger bodies – Templates H3
- 13.8 Volume for the driver and the passenger heads – Templates H4
- 13.9 Equipment in the cockpit
- 13.10 Cockpit access
- 13.11 Driver's field of frontal visibility
- 13.12 Driver's field of lateral visibility
- 13.13 Cockpit temperature
- 13.14 Fuel tank compartment
- 13.15 Fuel Flow Metering installation volume
- 13.16 ES compartment
- 13.17 ERS compartment
- 13.18 ES to ERS compartment
- 13.19 Survival cell identification
- 13.20 Survival cell characteristics

ARTICLE 14: SAFETY EQUIPMENT

- 14.1 General
- 14.2 Fire extinguishers
- 14.3 Driver master switch
- 14.4 Rear view mirrors
- 14.5 Safety belts
- 14.6 Cockpit head padding
- 14.7 Cockpit leg padding
- 14.8 Wheel retention
- 14.9 Wheel tethers
- 14.10 Seat
- 14.11 Frontal Head Restraints
- 14.12 Towing eyes
- 14.13 Lifting devices
- 14.14 General electrical safety
- 14.15 Electronic Control Unit
- 14.16 General Circuit Breaker
- 14.17 Cables, lines, electrical equipment
- 14.18 Protection against electrical shock
- 14.19 Equipotential bonding
- 14.20 Isolation resistance requirements
- 14.21 Additional protection measures for the AC circuit
- 14.22 Isolation surveillance of chassis and power circuit
- 14.23 Power circuit

- 14.24 Power bus
- 14.25 Power circuit wiring
- 14.26 Power circuit connectors, automatic disconnection
- 14.27 Insulation strength of cables
- 14.28 Overcurrent trip (fuses)
- 14.29 Safety indicators
- 14.30 Charging units
- 14.31 Battery Management System
- 14.32 Accident data recorders (ADR) and high-speed accident cameras
- 14.33 Medical light

ARTICLE 15: SAFETY STRUCTURES

- 15.1 Rollover structures
- 15.2 Survival cell
- 15.3 Front Impact Absorbing Structure - FIAS
- 15.4 Rear Impact Absorbing Structure - RIAS
- 15.5 Modifications

ARTICLE 16: MATERIALS

- 16.1 Magnesium
- 16.2 Metallic materials

ARTICLE 17: FUEL

- 17.1 Supplying
- 17.2 Specifications

ARTICLE 18: TELEVISION CAMERAS AND TIMING TRANSPONDERS

- 18.1 Presence of cameras and camera housings
- 18.2 Transponders

ARTICLE 19: HOMOLOGATION

- 19.1 Principles
- 19.2 Car Homologation
- 19.3 Engine Homologation
- 19.4 ERS Homologation
- 19.5 Homologation calendar

ARTICLE 20: FINAL TEXT

APPENDIX 1: DRAWINGS

APPENDIX 2: POWER UNIT SYSTEMS, FUNCTIONS AND COMPONENTS

APPENDIX 3: COCKPIT AND SURVIVAL CELL

APPENDIX 4: POWER UNIT ENERGY FLOW

APPENDIX 4b: POWER UNIT ENERGY FLOW, MAXIMUM POWERTRAIN POWER

APPENDIX 5: SPECIFICATION FOR INTRUSION PANELS

APPENDIX 6: LIFTING DEVICES

ARTICLE 0: FOREWORD

The present regulations apply to cars built both as bespoke race prototypes as well as to race cars built taken an original road going hypercar as a base.

Whenever an article applies to both categories, it will span across the whole page width:

Common

If an article only applies to one type, the following layout applies:

Prototype	Hypercar
-----------	----------

ARTICLE 1: DEFINITIONS

1.1 “LE MANS HYPERCAR” – HYPERCAR

<p>A closed automobile designed solely for speed races on circuits or closed courses.</p>	<p>A closed automobile based on a hypercar modified to be able to compete in speed races on circuits or closed courses.</p> <p>Extreme car intended to be marketed for a road use, created by a car manufacturer of series cars, whose technical characteristics are out of the ordinary, considering the state of the art and the technique and production of its manufacturer.</p> <p>The exceptional nature of this automobile is appreciated in particular:</p> <ul style="list-style-type: none"> - its power, - its top speed, - the materials it is made of and the technologies used, - its price, - its rarity, especially to be produced in limited quantities. <p>Hypercars thus characterized, being initially designed for road use and not for competition, must be marketed by the manufacturer as a road car and must appear in its catalog.</p>
---	---

1.2 Automobile

A land vehicle running on at least four non-aligned complete wheels, of which at least two are used for steering and at least two for propulsion.

1.3 Land vehicle

A locomotive device propelled by its own means, moving by constantly taking real support on the earth's surface, of which the propulsion and steering are under the control of a driver aboard the vehicle.

1.4 Bodywork

All entirely sprung parts of the car in contact with the external air stream, except cameras and the parts definitely associated with the mechanical functioning of the engine, transmission and running gear. Airboxes, radiators and engine exhausts are considered to be part of the bodywork.

1.5 Wheel centre line

The centre line of any wheel shall be deemed to be half way between two straight edges, perpendicular to the surface on which the car is standing, placed against opposite sides of the complete wheel at the centre of the tyre tread.

1.6 Height measurements

All height measurements related to the car will be taken normal to and from the reference plane.

1.7 Distances

All measurements relative to wheel centre lines, car centre plane and survival cell planes will be taken parallel to the reference plane.

1.8 Wheel

Flange and rim.

1.9 Complete wheel

Wheel and inflated tyre. The complete wheel is considered part of the suspension system.

1.10 Automobile make

An automobile make corresponds to a complete car.

When the car manufacturer fits an engine which it does not manufacture, the name of the engine manufacturer shall be associated with that of the car manufacturer. The name of the car manufacturer must always precede that of the engine manufacturer.

1.11 Event

Any event entered into the FIA WEC Championship Calendar for any year commencing at the scheduled time for scrutineering and sporting checks and including all practice and the race itself and ending at the later of the time for the lodging of a protest under the terms of the Sporting Code and the time when a technical or sporting verification has been carried out under the terms of that Code.

1.12 Weight

It is the weight of the car without the driver, at all times during the Event.

It may be measured without fuel on-board.

1.13 Engine cubic capacity

The volume swept in the cylinders of the engine by the movement of the pistons. This volume shall be expressed in cubic centimetres. In calculating engine cubic capacity, the number Pi shall be 3.1416.

In the case of a rotary engine, the engine cubic capacity is the volume determined by the difference between the maximum and minimum capacities of the combustion chambers.

1.14 Pressure charging

Increasing the weight of the charge of the fuel/air mixture in the combustion chamber (over the weight induced by normal atmospheric pressure, ram effect and dynamic effects in the intake and/or exhaust system) by any means whatsoever. The injection of fuel under pressure is not considered to be pressure charging.

1.15 Cockpit

The volume which accommodates the driver and the passenger.

The cockpit is the internal volume inside the chassis which is defined by the top of the car, the floor, the doors, the side panels, the glass areas and the front and rear bulkheads.

1.16 Sprung suspension

The means whereby all complete wheels are suspended from the unit comprising the survival cell/power unit/gearbox by a spring medium.

1.17 Survival cell

The continuous structure containing the fuel tank, and the cockpit and the parts of the ES and ERS.

1.18 Camera

Television cameras the dimensions of which are defined.

1.19 Camera housing

A device which is identical in shape and weight to a camera and which is supplied by the relevant competitor for fitting to his car in lieu of a camera.

1.20 Cockpit padding

Non-structural parts placed within the cockpit for the sole purpose of improving driver comfort and safety. All such material must be quickly removable without the use of tools.

1.21 Brake calliper

All parts of the braking system outside the survival cell, other than brake discs, brake pads, calliper pistons, components directly associated with the system referred to in Article 11.7, brake hoses and fittings, which are stressed when subjected to the braking pressure. Bolts or studs which are used for attachment are not considered to be part of the braking system.

1.22 Electronically controlled

Any command system or process that utilises semi-conductor or thermionic technology.

A simple open-loop non-automatic electrical switch activated by the driver acting on one or more system(s) is not considered to be an electronic control. Such a system is also called passive.

1.23 Closed-loop electronic control system (active system)

A closed-loop electronic control system is a system in which:

- An actual value (controlled variable) is continuously monitored;
- The "feed-back" signal is compared with a desired value (reference variable);
- The system is then automatically adjusted according to the result of that comparison.

Such a system is also called active.

1.24 Front power train

The MGU-K and associated torque transmission systems, up to the drive shafts torque measurements.

1.25 Rear power train

The engine, MGU-K and associated torque transmission systems, up to the drive shafts torque measurements.

1.26 Power unit

The internal combustion engine, complete with its ancillaries, any energy recovery system and all actuation systems necessary to make them function at all times.

1.27 Energy Recovery System (ERS)

A system that is designed to recover energy from the car, store that energy and make it available to propel the car and, optionally, to drive any ancillaries and actuation systems necessary for its proper function.

1.28 Motor Generator Unit - Kinetic (MGU-K)

The Kinetic Motor Generator Unit is the electrical machine mechanically linked to the drive train as part of the ERS.

1.29 Energy Store (ES)

The ES cells (including any clamping plates), electrical connections between cells and its safety control electronics.

1.30 ES cells

The elementary part of the ES that produces and stores electricity through electro-chemical reactions.

1.31 DC-DC converter

An electronic circuit connected to the Energy Store and whose function is to regulate multi-level voltage outputs for use by the electrical and electronic components of the car and power unit. A DC-DC converter may only consume energy from the energy store and cannot recover energy into the Energy Store. The components directly supplied by the DCDC or indirectly supplied through the non ERS energy storage cannot be used to propel the car or to provide energy to the pressure charging system

1.32 Engine

The internal combustion engine including ancillaries and actuator systems necessary for its proper function.

1.33 Rotary engine

Engine of the type covered by the NSU Wankel patents.

1.34 Compressor inlet

A component containing a duct of closed cross section through which all air destined for combustion enters any compressor; the duct must extend upstream of any part of any variable geometry device permitted by Article 5.8.

1.35 Compressor outlet

One or more components, each of them containing a duct of closed cross section through which all air destined for combustion exits the compressor(s).

1.36 Combustion chamber

An enclosed space in the engine cylinder controlled by the opening and closing of the poppet valves in which combustion takes place.

1.37 Fuel injector

Any device or component that delivers fuel into an oxidiser.

1.38 Auxiliary oil tank

An auxiliary oil tank is a singular vessel connected to the engine whose sole function is to hold engine oil for the replenishment of the engine lubrication system.

1.39 High pressure fuel pump

A mechanical device whose sole function is to compress the fuel to the pressure required for the high-pressure injection. It may be electronically controlled.

1.40 Fuel Flow Meter (FFM)

A sensor whose function is to measure the flow of the fuel passing through it.

1.41 In-cylinder pressure sensor

A sensor whose function is to measure the pressure in the combustion chamber.

1.42 Supercharger

Any device pressure charging.

1.43 Ignition coil

Assembly including an induction coil that supplies the high voltage to the spark plug.

1.44 Ancillaries

A component whose function is to support the primary activities of a main system to allow it to operate. Unless specified otherwise, ancillaries may be mechanically or electrically driven. Any electrically driven ancillary cannot be linked mechanically to any drivetrain, including the Power Unit. Ancillaries cannot be used to propel the car.

1.45 Alternator

An alternator is an electrical generator that converts mechanical energy to electrical energy.

1.46 Starter motor

A starter motor is a device used to rotate an engine so as to initiate the engine's operation under its own power. Starter motor can be electric, pneumatic, or hydraulic. It must have a maximum power of 20 kW and if its power is above 4 kW it must be fitted with an IVT sensor. The starter may possibly be part of the alternator.

1.47 Engine inlet

One or more components each of them containing a duct of closed cross section through which all air destined for combustion flows.

1.48 Original car, part and engine

The original car is the car produced by an OEM and homologated according to ECE, DoT or any other equivalent road car homologation, and from which the race car described in the present regulations is derived.

An original part is a part which has undergone all the stages of production foreseen and carried out by the manufacturer of the vehicle concerned, and originally fitted on the vehicle.

The original engine is the series production engine mounted on the original car.

1.49 Engine BSFC

The BSFC (Brake Specific Fuel Consumption) is a measure of the fuel efficiency of a system. It is the rate of fuel consumed by the system divided by the power produced by the system.

1.50 Gearbox

A gearbox is defined as all the parts in the drive line which transfer torque from the Power Unit output shafts to the drive shafts (the drive shafts being defined as those components which transfer drive torque from the sprung mass to the un-sprung mass).

It includes all components whose primary purpose is for the transmission of power or mechanical selection of gears, bearings associated with these components and the casing in which they are housed.

1.51 Differential

A differential is defined as a gear train that permits two drive shafts connected to two different wheels of the same drive train to rotate at different speeds while being driven by a third shaft.

1.52 Ride height

Distance between the reference plane and the ground.

The front ride height (FRH) will be taken at the front axle centerline and the rear ride height (RRH) at the rear axle centerline.

1.53 Frontal area

The projected frontal area of the car excluding tires.

It will be measured with FRH=RRH= 50 mm.

1.54 Cartesian coordinate system**1.54.1 Complete car**

The three-dimensional cartesian coordinate system, with origin O being on the reference surface at vertical position of front axle centre and axis lines X, Y and Z, oriented as shown by the arrows must be used.

The X direction is in the reference plane backward, the Y direction is toward the right, the Z direction is toward the top.

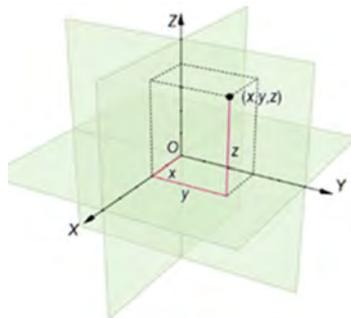
**1.54.2 For the survival cell**

The reference will be defined on a case by case basis according to the following principles:

- Xref: forward face of rear rollover structure, parallel to X0;
- Yref: car centreline, identical to Y0;
- Zref: survival cell reference plane, parallel to Z0 at the lowest point of the survival cell.

1.55 Stall prevention system

A system that acts automatically on the power unit and/or gearbox and/or clutch controls to prevent the internal combustion engine from stalling.

ARTICLE 2: GENERAL PRINCIPLES

2.1 Role of the FIA/ACO and basic principles

The following technical regulations are issued by the FIA/ACO.

What is not expressly permitted by the present regulations is prohibited.

The car must be, in any circumstances, under the control of the driver.

2.2 Amendments to the regulations

These Technical Regulations apply to the Championship taking place and referred to in the title (“the Championship”) and may only be changed after 1st January of the year with the unanimous agreement of all competitors, save for changes made by the FIA/ACO for safety reasons which may come into effect without notice or delay.

2.3 Dangerous construction

The stewards may exclude a vehicle whose construction is deemed to be dangerous.

It is the responsibility of the manufacturer to produce a safe car. FIA/ACO may request any testing or information to ensure the safe construction of the car.

2.4 Compliance with the regulations

Automobiles must comply with these regulations in their entirety at all times during an Event.

Should a competitor introduce a new design or system or feel that any aspect of these regulations is unclear, clarification may be sought from the FIA/ACO Technical Department and validated with the Endurance Committee. If clarification relates to any new design or system, correspondence must include:

- a) A full description of the design or system.
- b) Drawings or schematics where appropriate.
- c) The competitor's opinion concerning the immediate implications on other parts of the car of any proposed new design.
- d) The competitor's opinion concerning any possible long-term consequences or new developments which may come from using any such new designs or systems.
- e) The precise way or ways in which the competitor feels the new design or system will enhance the performance of the car.

2.5 Measurements

When not stated otherwise, all measurements must be made while the car is stationary on a flat horizontal surface and with the race setup.

Infinite precision can be assumed on certain dimensions provided it is clear that such an assumption is not being made in order to circumvent or subvert the intention of the relevant regulation.

2.6 Duty of Competitor

It is the duty of each competitor to satisfy the FIA/ACO technical delegates and the stewards that his automobile complies with these regulations in their entirety at all times during an Event.

The design of the car, its components and systems shall, with the exception of safety features, demonstrate their compliance with these regulations by means of physical inspection of hardware or materials. No mechanical design may rely upon software inspection as a means of ensuring its compliance.

ARTICLE 3: BODYWORK AND DIMENSIONS**3.1 Overall dimensions****3.1.1 Height**

No part of the bodywork except from the FIA/ACO antenna device described in the Appendixes to these Regulations may be more than:

<ul style="list-style-type: none"> • 1150mm above the reference plane. 	<p>whichever is higher:</p> <ul style="list-style-type: none"> • 1150mm above the reference plane, • the original car (with an absolute maximum of 1200 mm).
---	--

3.1.2 Bodywork Width

The overall bodywork width of the car must not exceed:

- 2000 mm

3.1.3 Overhangs

No part of the car may be more than:

- 1100 mm forward the front wheel centre line

No part of the car may be more than:

- 1000 mm rearward the rear wheel centre line

3.1.4 Overall length

The overall bodywork length of the car must not exceed:

- 5000 mm

3.1.5 Wheelbase

3150 mm maximum

3.1.6 Bodywork Frontal area

The bodywork frontal area must be no less than 1.6 m².

3.1.7 Headlight height

The headlights main beam center shall be no less than 400 mm above (in the Z-direction) the reference plane.

3.2 Doors

Doors must provide a normal access to the cockpit through the opening as specified in Article 13.10.2.

Opening (hinges) or locking (locks) devices must be designed to allow a quick release of the entire door in case of emergency from the interior as from the exterior of the cockpit with the use of gloves.

Hinges and locks must be marked in a signal colour.

3.3 Windscreen and glass areas**3.3.1 Windscreen**

Mandatory, made of one piece of polycarbonate (minimum thickness of 6 mm), or equivalent material.

The windscreen must be able to be removed by the marshals with the use of a #4 Allen key and with a maximum of 16 Tridair bolts.

Electrical demisting allowed.

3.3.2 Glazing

Side windows made of polycarbonate (minimum thickness of 2.0 mm) are mandatory;

An additional frame may be added, but it must be solidly fixed and it must not obstruct the driver's lateral vision defined in Article 13.12;

An opening of 40 cm² minimum for extracting air from the cockpit must be made on the rear part of each side window or each cockpit access;

3.4 Bodywork

3.4.1 General

Only one bodywork may be homologated.

Only one bodywork adjustable aerodynamic device (such as a wing, flap...) may be used. Whatever the position of this device, the car must fulfill the aerodynamic criteria defined in the Appendixes to these Regulations at all times. In case a combined multi-wing is proposed as the adjustable aerodynamic device, relative adjustment between the wing elements is not allowed.

Movable and/or deformable bodywork parts/elements are forbidden when the car is in motion.

The addition of foil/film/tape over bodywork split lines must be as described in the homologation form.

Any system operated automatically and/or controlled by the driver to modify any airflow when the car is in motion is forbidden, unless explicitly authorized by the present regulations.

A cooling fan is authorized provided that:

- its only function is to adjust the temperature of the cockpit;
- the electrical power is less than 150 W;
- the fan outlet is within the cockpit.

3.4.2 Upper bodywork

Other than respecting all the constraints in these technical regulations, the upper bodywork:

is free subject to approval by FIA/ACO technical department.	Must follow the original car shape except local modifications needed for racing or for achieving compliance with the present regulations, subject to approval by FIA/ACO technical department.
--	--

Any quick-release fixing must be visible from the outside and clearly indicated (arrows in contrasting colour).

3.4.3 Bodywork visibility criteria

As viewed from above, from the side, and from the front the bodywork may allow mechanical components to be seen, subject to FIA/ACO approval.

As viewed from above, the front bodywork corners must have a minimum radius of 50 mm.

As viewed from the side, the bodywork must cover the complete wheels above the axle centrelines and it must be possible to see the circumference of the complete wheels.

Wheel arches may be a non-continuous surface (holes, grooves, louvers, openings or cut-outs) if required to accomplish the aerodynamic safety stability criteria as defined by Article 3.10, provided that the visibility requirements above are respected.

As viewed from the front, the bodywork must cover the complete wheels above the axle centrelines.

3.5 Underside of the car

3.5.1 General

Rearward of the front axle centreline and except for the skid block (see Article 3.5.6), no entirely sprung part must protrude below the reference plane.

	Other than respecting all the constraints in these technical regulations, the underside of the car must follow the original car shape except local modifications needed for racing or for achieving compliance with the present regulations.
--	--

The only openings permitted are the lift car jack holes, sensors for measuring the ground clearance, closed hatches (maintenance operations) and the overflow fuel pipe.

3.5.2 Reference plane

The reference plane is defined as being a horizontal plane defined by the lowest point of the bodywork and the upper surface of the skid block.

3.5.3 Rear diffuser

Free design.

3.5.4 Underside front area (front splitter)

In the area situated:

- rearward of the front perimeter of the car;
- forward of the front axle centerline;
- up to the overall width of the car,

all parts of bodywork visible from the underside must be situated above the reference plane.

In the area situated:

- rearward of the front perimeter of the car;
- 50 mm forward of the front axle centreline;
- over a minimum width of 1000 mm,

any sprung part of the car must be situated more than 50 mm above the reference plane.

3.5.5 Ground clearance

Any system, other than the suspension, which is designed so as to modify the ground clearance is not permitted (see Article 10.2.2);

No sprung part of the car is allowed lower than the reference plane, except the mandatory skid block described below; No un-sprung part of the car is allowed lower than the reference plane, except the complete wheel and the brake cooling duct (see Article 11.4).

Friction blocks are only permitted if their surface is continuous with the main part on which they are fitted. They must be made from a homogeneous material with a maximum density of 2.

3.5.6 Skid block

One skid block must be affixed underneath the reference plane.

It must:

- be made from a maximum of 4 parts;
- comply with Drawing 3C;
- the minimum thickness of any point on the friction area is 20 mm (see Drawing 3C);
- have no holes, cut outs or pockets on its outer surface other than:
 - those necessary to fix the skid block;
 - those necessary for the lift car jacks;
- have no holes, cut outs or pockets on its upper face when in vertical projection of the front and rear friction areas;
- the monobloc front and rear parts (described in Drawing 3C) must be made from a homogeneous material with a density between 1.3 and 1.45;
- the curved part (described in Drawing 3.C) must be made from a material with a mean density of less than 2;
- be fixed symmetrically about the centreline of the car in such a way that no air may pass between it and the reference plane;
- The leading and trailing edges of the skid block must be chamfered to a depth of 21 mm over a longitudinal distance of 200 mm;
- A seal with maximum diameter 3mm is acceptable if its thickness is non-existent when skid block is fitted;
- As viewed from below, fasteners used to attach the skid block to the reference plane must:
 - be fitted in order that their entire lower surfaces are visible from beneath the car and are no more than 19 mm from reference plane.
 - Two additional fasteners (one for the front part and one for the rear part) made of titanium must be used to attach the skid block. They must be symmetrical along the car centreline and be in the friction areas. The dimensions must be 40 mm (longitudinally) x 40 mm (transversally), with a +/-1 mm tolerance. Their lower surfaces must be visible from beneath the car and must be at 25 mm from the reference plane when new.

3.6 Exhaust pipe outlet

As principle, any device that can take advantage of exhaust flow to affect any aerodynamic characteristic of the car is forbidden.

e.g., it is forbidden to take advantage of exhaust flow to dynamically effect the tunnel of diffuser or intent to seal its edges, in both situations in the expectation to improve the diffuser's aerodynamic behaviour.

3.7 Aerodynamic criteria**3.7.1 Homologation process**

To be homologated, an aerodynamic configuration of the car must fulfil aerodynamic criteria.

These criteria will be controlled in the official FIA/ACO wind tunnel.

An aerodynamic configuration will be submitted to a full scan of ride heights to extract the aerodynamic characteristics (e.g. drag, downforce for different car attitudes).

The homologation procedure is described in the Appendixes to the Technical Regulations.

3.7.2 Definition of "Aerodynamic configuration"

An Aerodynamic configuration is defined by a combination of:

- Complete Bodywork
- An Adjustable Aerodynamic Device (AAD), e.g. Front or Rear wing, and its range of setup
- Brake blanking
- And any further elements deemed appropriated by FIA/ACO (e.g. gurneys, fillers, dive planes, louvers, etc).

Brake blanking will be homologated and must be:

- simple closing plates on duct inlets
- presented during wind tunnel tests
- satisfy the required aerodynamic criteria

Other types of blanking including power unit cooling options are forbidden.

3.7.3 Criteria

The aerodynamic coefficients must fulfil the criteria set in the Appendixes of these Technical Regulations.

3.8 Deflection

3.8.1 General deflection

The FIA/ACO reserves the right to introduce load/deflection tests on any part of the bodywork which appears to be (or is suspected of), moving whilst the car is in motion.

Competitors must supply the pads and adapters following instructions from FIA/ACO.

Among other criteria, the FIA/ACO will consider the linearity of the load/deflection curve over the elastic deformation area. Any non-linearity must be only on the plastic deformation area.

As a principle, at any point, in any direction X/Y/Z, no bodywork part should move more than 5mm when loaded (push/pull) with 100N. The way of application will depend of the particular shape of the part to be tested and the retained mean will not introduce specific stress in the part (capable to directly influence its behaviour).

Under application of the load, the part must still respect the technical regulations.

Brushes, rubber boots, rubber sealing will only be accepted to prevent rubber pick-up (such devices should be presented during homologation process).

3.8.2 Front bodywork parts

No point of bodywork described in Article 3.5.4 (front splitter) must deflect more than 15mm vertically when a combination of the following vertical loads is applied:

The main load will be applied vertically downward by eight M5 inserts structurally integrated in the part and reachable in the bottom surface.

As basic requirements, these inserts must:

- Be positioned symmetrically regarding the longitudinal vertical plane of the car.
- One row of four parallel to the front axle and located at 500 mm from the front axle with the two lateral ones at 100 mm from maximum car width and the two remaining such that all four are equidistant;
- One row of four parallel to the front axle and located at 100mm from leading edge with two lateral ones at 100 mm from maximum car width and the two remaining such that all four are equidistant.
- If the M5 inserts cannot be located in the positions above due to the construction of the underside front area, alternative positions may be agreed with the FIA/ACO.

The load will be equally applied on each insert up to a total of 8000N.

3.8.3 Engine cover

The rearmost part of the engine cover must deflect no more than 5 mm vertically when a load of 100 N is applied.

The load may be applied at any point along the trailing edge or the gurney. These loads will be applied using a suitable 15 mm wide adapter which must be supplied by the competitor.

The load/deflection ratio must be constant for a maximum load of 200 N and a maximum deflection of 10 mm.

3.8.4 Rear wing

The rearmost part of the rear wing (if present) must deflect no more than 5 mm vertically when a load of 100 N is applied.

The load may be applied at any point along the trailing edge. These loads will be applied using a suitable 15 mm wide adapter which must be supplied by the competitor.

The load/deflection ratio must be constant over the entire operating range of the wing and applies for a maximum load of 200 N and a maximum deflection of 10 mm.

3.8.5 Front skid block

The front part of the skid block must deflect no more than 5mm vertically when a 2500N load is applied vertically at any point of the friction surface (see Drawing 3C). The load will be applied in an upward direction using a 50mm diameter ram.

Stays or structures between the front of the bodywork lying on the reference plane and the survival cell may be present, provided they don't allow non-linear deflection or speed depend deflection during any part of the test including the release of the load.

The front part of the skid block may deflect no more than 15mm vertically when a load able to lift the front wheels from the ground is applied.

3.8.6 Rear skid block

The rear part of the skid block must deflect no more than 5mm vertically when a 5000N load is applied vertically at any point of the friction surface (see Drawing 3C). The load will be applied in an upward direction using a 50mm diameter ram.

Stays or structures between the front of the bodywork lying on the reference plane and the survival cell may be present, provided they don't allow non-linear deflection or speed depend deflection during any part of the test including the release of the load.

3.9 Bodywork construction

3.9.1 General

In order to avoid the spread of debris on the track following an accident, the outer skins of the front bodywork in the vicinity of the front wheels, must be made predominantly from materials which are included for the specific purpose of containing debris.

The FIA/ACO must be satisfied that all such parts are constructed in order to achieve the stated objective.

3.9.2 Tolerances

To help overcome any possible manufacturing problems, and not to permit any design which may contravene any part of these regulations, the following dimensional tolerances are permitted on bodywork: a tolerance of +/- 3 mm is permissible across the surfaces lying on the reference planes and a horizontal tolerance of 3mm is permitted when assessing whether a surface is visible from beneath the car.

3.10 Aerodynamic stability

Regardless of the aerodynamic configuration, the car must fulfill a number of safety criteria to ensure a minimum aerodynamic stability. Compliance with Article 2.3 is understood as a car being aerodynamically stable according to these safety criteria at all times. The criteria acceptance will be validated with Wind Tunnel measurements and/or CFD computations. The complete procedure and acceptance requirements for these criteria are described in the aerodynamic homologation process that can be found in the Appendixes to these regulations.

ARTICLE 4: WEIGHT

4.1 Minimum weight

The weight of the car, without fuel and without driver, must not be less than 1030 Kg at all times during the competition.

The checking of the weight of any part that may have been replaced during the event is at the discretion of the Scrutineers.

4.2 Weight distribution

The weight distribution (applied on the front wheels versus the complete car) must be homologated with a tolerance of +/-0.5%.

For this check, the car must be complete without fuel and without driver.

4.3 Ballast

Ballast may be used provided it is secured in such a way that tools are required for its removal. It must be possible to fix seals if deemed necessary by the FIA/ACO technical delegates.

Movable ballast is forbidden.

Cars must be engineered in order to be able to accept a maximum of +50 kg of BoP ballast (above the minimum car weight).

All ballast positioned within the perimeter of the crash test components must be present during the crash tests.

No ballast is allowed in the vertical projection of the front and rear impact absorbing structures.

BoP ballast must be fitted between the front and rear wheel axles.

4.4 Liquids

The weight may be checked at any time during the competition with the quantity of liquids remaining in the tanks, but at the end of the practice sessions or the race the car will have all fuel drained before being weighed.

ARTICLE 5: POWER UNIT

5.1 General

5.1.1 Definition

Unless explicitly permitted for a specific application, the use of any device, other than the engine described in Article 5.2 connected to the rear drivetrain, and an optional ERS described in Article 5.3 to propel the car, is not permitted. Energy flows, power and ES state of charge limits are defined in the energy flow diagram shown in Appendix 4 of these regulations.

When the car is on the track a lap will be measured on each successive crossing of the finish line timing loop, however, when entering the pits the lap will end at the pit entry timing loop and next lap will start at the pit exit timing loop. Electrical DC measurements must be used to verify that the energy and power requirements are being respected. Parts are named based on an engine with reciprocating pistons. The equivalence for other engines can be found in the Appendixes to these regulations.

5.1.2 Powertrain Performance

The Powertrain performance must be declared and homologated according to the procedure detailed in Article 19 of these regulations.

The Powertrain performance must not exceed, at any time, the power curve described in Appendix 4b (subject to BoP adjustment).

The rear power train performance must not exceed, at any time, whichever is lower of:

- the power curve described in Appendix 4b (subject to BoP) plus 3 %.
- the power curve described in Appendix 4b corresponding to a peak power of 520 kW (High Adjustment)

Details of the management of the Powertrain Performance can be found in the Appendixes to these regulations.

5.2 Engine:

The engine must be homologated according to the procedure detailed in Article 19 of these regulations.

5.2.1 Origin of the engine

The engine must be:

<ul style="list-style-type: none"> • either a bespoke engine, • or based on an “engine of the make” 	<ul style="list-style-type: none"> • either based on the original engine, • or based on a series production engine mounted in a model of car of the same group produced in a quantity of more than 300 units per year.
---	--

5.2.2 Engine specifications

Engine design is free except for the following restrictions:

- Only Petrol 4 stroke engines are permitted.
- With the exception of incidental leakage through joints (either into or out of the system) all and only the air entering the engine inlet must enter the combustion chambers.

<p>5.2.2.1 Bespoke engine:</p> <ul style="list-style-type: none"> • Variable geometry devices (including nozzle turbines) are not allowed except for rotary engines. • Engine must not have more than two inlet and two exhaust valves per cylinder. <ul style="list-style-type: none"> - Only reciprocating poppet valves with axial displacement are permitted. - The sealing interface between the moving valve component and the stationary engine component must be circular. - Electromagnetic and hydraulic valve actuation systems are forbidden. <p>5.2.2.2 Engine of the make:</p>	
--	--

<p>The engine of the make is a series engine. that meets the following conditions:</p> <ul style="list-style-type: none"> • At least 25 identical engines identical to the ones destined for a series production car homologated for road use equipped with this engine must have been produced; • At least 25 identical series production car homologated for road use equipped with this engine are produced by the end of the year of the first season this engine is competing in. • At least 100 identical series production car homologated for road use equipped with this engine are produced by the end of the year of the second season this engine is competing in. • The series engine is homologated with FIA/ACO. • One complete engine is deposited with the FIA/ACO. 	
	<p><i>5.2.2.3 Original engine and series production engine:</i></p> <ul style="list-style-type: none"> • Variable geometry devices are allowed provided that the system remains exactly as homologated for the original engine.

5.2.3 Engine modifications allowed to a base original engine, engine of the make or series production engine

The modifications are free with the following exceptions and subject to FIA/ACO approval:

5.2.3.1 Engine block

The cylinder block casting must come from the base engine.

The cylinder block may be modified:

- By machining:
 - for the modification of the bore or for sleeving if the original block is not fitted with sleeves.
 - below the horizontal plane passing through the centreline of the crankshaft bearings, for the mounting of the dry sump.
 - the cylinder head gasket plane providing that the deck height (distance between cylinder head plane and crankshaft centreline) stays within 1 mm of the original engine dimension.
 - for the sole purposes of reinforcement and reliability, the raw casting may be machined differently to increase cross sections or leave more material in specific areas, provided that the original part remains identifiable.
- By addition of material:
 - addition of material for local and/or structural reinforcement may be done by weld or glued patches. Reinforcements cannot be done on an area of the part where material has been removed from the original engine part by more than a 1 mm thick layer.
 - lubrication holes, lubrication injector holes may be modified or closed

5.2.3.2 Crankshaft

May be changed. Free design. Its weight must not be more than 10% lower than the original.

The firing order is free.

5.2.3.3 Cylinder Head

The cylinder head castings must come from the original engine.

Valve angles, number and location of camshafts must remain original, as they are fitted on the original engine.

The cylinder heads may be modified:

- By machining:
 - provided that the original part remains identifiable.
- By addition of material:
 - addition of material for local reinforcement can be done may be done by weld or glued patches. Reinforcement cannot be done on an area of the part where material has been removed from the original engine part by more than a 1 mm thick layer.
 - inserts may be added in the intake ports.
 - valve tappet guides may be fitted with sleeves if not originally.

- lubrication holes, lubrication injector holes may be modified or closed.
- the use of helicoils is permitted

5.3 ERS

An ERS is optional.

If fitted, the ERS as defined in the relevant column of the ERS table of appendix 2 of these regulation must comply with the provisions below.

The ERS must be homologated according to the procedure detailed in Article 19 of these regulations.

5.3.1 Origin of the ERS

The ERS must:

<ul style="list-style-type: none"> • either use a bespoke front MGU-K; • or use a front MGU-K of the make; 	<ul style="list-style-type: none"> • either use a bespoke front MGU-K; • or have the same architecture as the original car, and: <ul style="list-style-type: none"> ○ either use a bespoke MGU-K; ○ or use the original MGU-K.
--	---

5.3.2 ERS specification

The electrical DC power of the MGU-K must not exceed 200 kW.

With the exception of the pit-lane the MGU-K can only apply positive torque to the front wheels:

- if the speed of the car is 120 kph or higher, when the car is fitted with dry weather slick tyres;
- if the speed of the car is between 140-160 kph or higher, when the car is not fitted with dry weather slick tyres;
- if the speed of the car is below 120 kph and stays below 120 kph until the car comes to the pits. (*)
- cannot be used for installation, reconnaissance and formation laps.

(*) To be regulated through the Sporting Regulations:

- if it happens in qualifying, all the laps of the run will be deleted

Electrical DC measurements at the MGU-K(s) electrical connections will be used to monitor the maximum MGU-K power. The speed will be measured by taking the Max of the 2 front wheel speeds from the FIA/ACO compulsory sensor (art. 8.4).

The fitting of wet tyres must be declared through the compulsory telemetry system described in article 8.6.

5.3.2.1 Bespoke MGU-K:

Free with the following exceptions and subject to FIA/ACO approval:

- Must be a system with a single MGU-K.
- The rotational speed of the MGU-K must not exceed 25,000 rpm.
- The laminate thickness of the MGU-K must not be less than 0.1 mm.

5.3.2.2 Single MGU-K:

In addition to the limitations imposed to each origin of ERS, the following restrictions apply:

- the MGU-K must be solely and permanently mechanically linked to a mechanical differential linked to the front wheels of the car. At the front, this mechanical link must be of fixed speed ratio to the front wheels.
- the front mechanical differential must have a unique and homologated ramp.

5.3.2.3 MGU-K of the make:

The ERS of the make is a series production MGU-K that meets the following conditions:

- At least 25 identical MGU-K identical to the ones destined for the series production car homologated for road use equipped with this MGU-K must have been produced;
- At least 25 identical series production car homologated for road use equipped with this exact same MGU-K are produced by the end of the year of the first season this engine is competing in.
- At least 100 identical series production car homologated for road use equipped with this exact same MGU-K are produced by the end of the year of the second season this exact same MGU-K is competing in.
- The MGU-K of the make is homologated with FIA/ACO.
- One complete MGU-K is deposited with the FIA/ACO.
- The rotational speed of the MGU-K of the make is free.
- The laminate thickness of the MGU-K of the make is free.

- The MGU-K of the make is not subject to Article 5.14.

5.3.2.4 Original MGU-K and MGU-K of the make with twin MGU-K:

In addition to the requirements of Article 5.3.2.3 for the MGU-K of the make, the following restrictions apply:

- The torque control must ensure a total equity with a single MGU-K solely and permanently mechanically linked to a mechanical differential linked to the front (rear) wheels of the car, this mechanical link must be of fixed speed ratio to the front (rear) wheels.
- Torque must be applied in such a way as to simulate a mechanical (viscous) differential of fixed characteristic. Additionally, it must not supply more torque to the faster rotating wheel than the slower rotating wheel except in the case of motor shutdown (any shutdown must latch until the car comes to a halt).
- In-wheel MGU-K are not allowed

5.3.3 Modifications allowed to the original MGU-K or MGU-K of the make

No modifications are allowed.

5.4 Weight and centre of gravity

5.4.1 The weight of the engine must be a minimum of 165 kg.

5.4.2 The centre of gravity of the engine may not lie less than 220 mm above the reference plane.

5.4.3 When establishing conformity with Articles 5.4.1 to 5.4.2 the perimeter will be defined in accordance with the table shown in Appendix 2 of these regulations.

5.5 Power unit torque demand

5.5.1 The only means by which positive torque to front and/or rear power train may be requested is a single foot (accelerator) pedal mounted inside the survival cell and only actuated by the driver.

Positive torque is understood to be when the sum of both homologated torque sensors per axle is positive on a 0.2s average.

5.5.2 Designs which allow specific points along the accelerator pedal travel range to be identified by the driver or assist him to hold a position are not permitted.

5.5.3 In the case of an an ERS with one MGU-K per front wheel, the side to side torque transfer function must be unique and homologated with the ERS.

5.5.4 For safety reasons, whenever the ICE is not running, and the car can be driven (including, but not limited to: ERS active or starter connected to rear wheels via gearbox), two simultaneous actions (one of them being hand-operated) are required from the driver to demand positive torque.

5.6 Power unit control

5.6.1 Homologated sensors must be fitted which measure the torque supplied to each driveshaft (**Technical List n° TBD**). These signals must be provided to the FIA/ACO datalogger. Installation details can be found in the appendixes to these regulations. **Any device, system or procedure the purpose and/or effect of which is to deceive the measures taken or signals sent by these sensors is prohibited.**

5.6.2 In-cylinder pressure sensors are forbidden.

5.7 Engine fuel systems

5.7.1 No fuel injectors are permitted downstream of the exhaust valves or of the exhaust port inlet on a rotary engine.

5.7.2 A homologated "Fuel Flow Meter" (Technical List n°45) must be integrated into the fuel system according to Article 6.6.

Communication with fuel flow meter must be done by CAN protocol.

Fuel flow meter information is to be sent directly to the FIA/ACO data logger without going through the competitor electronic unit.

5.7.3 All fuel delivered to the engine must pass through this homologated meter, and must all be delivered to the combustion chambers by the fuel injectors mentioned in Article 5.7.1.

5.7.4 Homologated sensors which directly measure the pressure and temperature of the fuel supplied to the fuel injectors must also be fitted, these signals must be supplied to the FIA/ACO data logger.

5.7.5 Any device, system or procedure the purpose and/or effect of which is to increase the flow rate or to store and recycle fuel after the measurement point is prohibited.

5.8 Ignition systems

5.8.1 With the exception of rotary engines, the ignition is only permitted by means of a single ignition coil and single spark plug per cylinder. No more than five sparks per cylinder per engine cycle are permitted. The use of plasma, laser or other high frequency ignition techniques is forbidden.

5.8.2 Only conventional spark plugs that function by high tension electrical discharge across an exposed gap are permitted.

Spark plugs are not subject to the materials restrictions described in Articles 5.12 and 5.13.

5.9 Engine ancillaries

5.9.1 Engine ancillaries can be mechanically or electrically driven.

Any electrically driven ancillary cannot be linked mechanically to any drivetrain, including the power unit with the sole exceptions being the alternator and the starter motor.

5.9.2 The alternator cannot transmit torque to the drivetrains. The alternator cannot be directly connected to the power circuit and cannot charge the ES, **only the auxiliary battery**.

5.9.3 The starter motor cannot transmit torque to the drivetrain while the car is in motion, except for cars without an ERS:

- in the pitlane to pull off from a pit stop
- to ensure the reverse function as required by article 9.7.

5.9.4 The turbocharger cannot be mechanically linked to the drivetrain.

5.10 Engine Inlet

5.10.1 The addition of any substance other than fuel, as described in Article 5.7.3, into the air destined for combustion is forbidden. The connection between the intake and the exhaust manifold is not allowed.

5.11 Materials and Construction – Definitions

5.11.1 A metallic material will be defined as a material that is made-up of metallic elements, whether that material is a pure metal, alloy of several metals or an inter-metallic.

In the case of a composite, this is designated a metallic material when the matrix or reinforcement, whatever phase proportion, is composed of metallic elements

5.11.2 Metallic elements are those designated by the periodic table, shaded blue below:

The periodic table is color-coded into three main groups: METALS (blue), METALLOIDS (orange), and NONMETALS (green). The table includes element symbols, atomic numbers, and names. Groups are labeled 1A through 8A, and periods are labeled 1 through 7. The lanthanide and actinide series are shown below the main table.

5.11.3 Non-metallic materials will include pure and impure compounds such as oxides, nitrides, silicides etc, and material with organic matrices such as carbon and Kevlar reinforced composites.

5.11.4 X Based Alloy (e.g. Ni based alloy) – X must be the most abundant element in the alloy on a %w/w basis. The minimum possible weight percent of the element X must always be greater than the maximum possible of each of the other individual elements present in the alloy.

5.11.5 X-Y Based Alloy (e.g. Al-Cu based alloy) – X must be the most abundant element as in Article 5.11.4 above. In addition, element Y must be the second highest constituent (%w/w), after X in the alloy. The mean content of Y and all other alloying elements must be used to determine the second highest alloying element (Y).

5.11.6 Intermetallic Materials (e.g. TiAl, NiAl, FeAl, Cu3Au, NiCo) – These are materials where the material is based upon intermetallic phases, i.e. the matrix of the material consists of greater than 50%v/v intermetallic phase(s). An intermetallic phase is a solid solution between two or more metals exhibiting either partly ionic or covalent, or metallic bonding with a long-range order, in a narrow range of composition around the stoichiometric proportion.

5.11.7 Composite Materials – These are materials where a matrix material is reinforced by either a continuous or discontinuous phase. The matrix can be metallic, ceramic, polymeric or glass based. The reinforcement can be present as long fibres (fibre length greater than 13mm) or short fibres, whiskers and particles (discontinuous reinforcement). Nanoscale reinforced materials are to be considered as composites. (a reinforcement is considered to be nanoscale if any dimension of the reinforcement is less than 100nm.)

5.11.8 Metal Matrix Composites (MMC's) – These are composite materials with a metallic matrix containing a minimum ratio of 0.5% volume/volume of other ceramic, metallic, carbon or intermetallic phase which is not soluble in the liquid phase at 100°C above the melting point of the metallic matrix.

5.11.9 Ceramic Materials (e.g. Al2O3, SiC, B4C, Ti5Si3, SiO2, Si3N4) – These are inorganic, non-metallic solids.

5.11.10 Nanomaterials: Nanomaterials are purposely created objects that have one or more dimensions (e.g. length, width, height, diameter) which is less than 100nm. (1nm = is 1 x 10-9 metres.)

5.12 Materials and construction – General

5.12.1 Unless explicitly permitted for a specific application, the following materials may not be used anywhere on the power unit:

- a) Magnesium based alloys.
- b) Metal Matrix Composites (MMC's) containing more than 2.0% volume/volume of other ceramic, metallic, carbon or intermetallic phase which is not soluble in the liquid phase at 100°C above the melting point of the metallic matrix.
- c) Intermetallic materials.
- d) Alloys containing more than 5% by weight of Platinum, Ruthenium, Iridium or Rhenium.
- e) Copper based alloys containing more than 2.75% Beryllium.
- f) Any other alloy class containing more than 0.25% Beryllium.
- g) Tungsten base alloys.
- h) Ceramics and ceramic matrix composites.
- i) Aluminium based alloys containing more than 2.5 weight % Lithium
- j) Materials containing nanomaterials.
- k) Thermal insulation containing unbound nanomaterials

5.12.2 Unless explicitly permitted otherwise for a specific application, only material approved by the FIA/ACO Technical Department may be used on the power unit. The approval of the FIA/ACO Technical Department is conditional upon the material concerned being available on a non-exclusive basis and under normal commercial terms to all competitors.

5.12.3 The restrictions in Article 5.12.1 do not apply to coatings provided the total coating thickness does not exceed 25% of the section thickness of the underlying base material in all axes. In all cases, other than under Article 5.12.4.b, the relevant coating must not exceed 0.8mm.

Where the coating is based on Gold, Platinum, Ruthenium, Iridium or Rhenium, the coating thickness must not exceed 0.035mm.

5.12.4 The restrictions in Article 5.12.1.h do not apply to the following applications:

- a) Any component whose primary purpose is for electrical or thermal insulation.
- b) Any coating whose primary purpose is for thermal insulation of the outside of the exhaust system.

5.12.5 Magnesium based alloys, where permitted, must be available on a non-exclusive basis and under normal commercial terms to all competitors. Only those alloys covered by ISO16220 or ISO3116 and approved by the FIA may be used.

5.12.6 The restrictions in article 5.12.1 b do not apply to TiB2 grain refinement of aluminium-copper based materials. TiB2 additions for the purpose of grain refinement are permitted up to a maximum of 5% v/v.

5.13 Materials and construction – Components

5.13.1 Pistons must respect Article 5.12. Titanium alloys are not permitted. Rotor seals on rotary engines may be manufactured from a ceramic material.

5.13.2 Piston pins must be manufactured from an iron-based alloy and must be machined from a single piece of material.

5.13.3 Connecting rods must be manufactured from iron or titanium-based alloys and must be machined from a single piece of material with no welded or joined assemblies (other than a bolted big end cap or an interfered small end bush).

5.13.4 Crankshafts must be manufactured from an iron-based alloy.

With the exception of securing high weight density balance weights, no welding is permitted between the front and rear main bearing journals.

No material with a density exceeding 18800 kg/m³ may be assembled to the crankshaft.

These parts assembled to the crankshaft may be manufactured in a Tungsten-based material.

5.13.5 Camshafts must be manufactured from an iron-based alloy.

Each camshaft and lobes must be machined from a single piece of material.

No welding is allowed between the front and rear bearing journals.

5.13.6 Valves must be manufactured from intermetallic materials or from alloys based on Aluminium, Iron, Nickel, Cobalt or Titanium. Hollow stems and heads (e.g. sodium, lithium or similar, filled for cooling) are permitted. In addition, the restrictions detailed in Articles 5.12.3 and 16.1 do not apply to valves.

5.13.7 Reciprocating and rotating components

- a) Reciprocating and rotating components must not be manufactured from graphitic matrix, metal matrix composites or ceramic materials, this restriction does not apply to the clutch and any seals.
- b) Rolling elements of rolling element bearings must be manufactured from an iron-based alloy or from a ceramic material.
- c) All timing gears between the crankshaft and camshafts (including hubs) must be manufactured from an iron-based alloy.
- d) High pressure fuel pumps elements may be manufactured from a ceramic material.
- e) Torsional damper elements may be manufactured in a Tungsten based material.

5.13.8 Static components

- a) Other than inserts within them, engine crankcases including sump, cylinder heads and cylinder head cam covers must be manufactured from cast or wrought aluminium or iron alloys.
No composite materials or metal matrix composites are permitted either for the whole component or locally.
- b) Other than parts listed in a) above, magnesium-based alloys are permitted for static parts included in the sealed perimeter as described in Line 1 of the Appendix 2 table.
- c) Any metallic structure whose primary or secondary function is to retain lubricant or coolant within the engine must be manufactured from an iron-based alloy, an aluminium alloy or a magnesium-based alloy if permitted by Article b) above.
- d) All threaded fasteners, other than the two exceptions below, must be manufactured from an alloy based on Cobalt, Iron or Nickel. The exceptions are:
 - i) Fasteners whose primary function requires them to be an electrical insulator may be manufactured from ceramic or polymeric materials.
 - ii) Fasteners that are used in electronic control units may be manufactured from aluminium or copper-based alloys or polymeric (plastic) materials.
 Composite materials are not permitted.
- e) Valve seat inserts, valve guides and any other bearing component may be manufactured from metallic infiltrated pre-forms with other phases which are not used for reinforcement.
- f) Ballast may be manufactured in a Tungsten based material.
- g) Magnesium based alloys are permitted for static parts of Power Unit ancillaries.
- h) Magnesium based alloys are permitted for the compressor housing (from compressor inlet to compressor outlet).
- i) Magnesium based alloys are permitted for all metallic casings for electronic systems.

5.14 Materials and construction – Energy recovery, storage systems and electronic systems

5.14.1 Energy storage and ERS devices are not subject to Articles 5.12.1 b), c) nor to 5.12.3.

5.14.2 Permanent magnets in electrical machines are not subject to Articles 5.12.1 b), c) nor to Article 5.12.3.

5.14.3 MGU-K casing must be manufactured from cast or wrought aluminium alloys.

5.14.4 Unless explicitly permitted for a specific application, the following materials may not be used anywhere on the MGU-K:

- a) Cobalt, Titanium, Gold and Silver based alloys, with the exception of MGU-K's rotor bolts, which may be made in Titanium based alloy;
- b) Alloys containing samarium with laminate thickness less than 2 mm;
- c) Composite materials or metal matrix composites with the exceptions of brackets used for magnet retention;
- d) With the exception of permanent magnets, alloys containing cobalt or nickel.

5.14.5 Electronic components contained inside electronic units are not subject to any material restriction.

5.14.6 The ES must contain only one type of cell, except the one for the Battery Management System (BMS) backup battery.

5.14.7 ES Cells materials are not subject to Article 5.12.1.j.

5.15 Starting the engine

No supplementary device temporarily connected to the car may be used to start the engine in the team's designated garage area, in the pit lane and on the grid.

5.16 Stall prevention systems

If a car is equipped with a stall prevention system, and in order to avoid the possibility of a car involved in an accident being left with the engine running, all such systems must be configured to stop the engine no more than ten seconds after activation.

The sole purpose of such systems is to prevent the engine stalling when a driver loses control of the car. If the car is in second gear or above when the system is activated multiple gear changes may be made to either first gear or neutral, under all other circumstances the clutch alone may be activated.

Each time such a system is activated the clutch must be fully disengaged and must remain so until the driver de-activates the system by manually operating the clutch with a request greater than 95% of the total available travel of the drivers clutch actuation device.

5.17 Replacing power unit parts

All parts outside the sealed perimeter as described in line 1 of the Appendix 2 table may be replaced.

ARTICLE 6: FUEL SYSTEM

6.1 Principles

6.1.1 All fuel pumps must be in operation only when the engine is running or being started.

6.1.2 Feed pumps supplying the collector from the tank may be switched on during a pit-stop by means of a specific human action on a switch different from the main one in order to activate again the fuel pumps after they have been stopped with engine stop or engine stall.

6.1.3 The fuel system is free provided the provisions in the following articles are complied with.

6.2 Fuel tanks

6.2.1 The fuel tank must be a single rubber bladder conforming to or exceeding the specifications of FIA Standard FT5-1999. A list of approved materials may be found in Technical List No.1.

6.2.2 When viewed from top, all the fuel stored on board the car must be located:

No more than 500 mm from the longitudinal axis of the car.

Behind Template H3 and no more than 500 mm from Xref plane.	Behind the driver and the passenger's seats.
---	--

6.2.3 A maximum of 1 litre of fuel may be kept outside the survival cell, but only that which is necessary for the normal running of the engine.

6.2.4 The pressure in the fuel tank must not exceed 2 bar.

6.2.5 The pressure of the low-pressure circuit (including the FFM) is limited to 10 bar maximum. A fuel pressure above 10 bar is considered as high pressure.

6.3 Fittings and piping

6.3.1 All apertures in the fuel tank must be closed by hatches or fittings which are secured to metallic or composite bolt rings bonded to the inside of the bladder. The total area of any such hatches or fittings which are in contact with the fuel may not exceed 70'000 mm².

Bolt hole edges must be no less than 5mm from the edge of the bolt ring, hatch or fitting.

6.3.2 All fuel lines between the fuel tank and the engine must have a self-sealing breakaway valve. This valve must separate at less than 50% of the load required to break the fuel line fitting or to pull it out of the fuel tank.

6.3.3 No lines containing fuel may pass through the cockpit.

6.3.4 All lines must be fitted in such a way that any leakage cannot result in the accumulation of fuel in the cockpit.

6.3.5 All components containing fuel at a pressure greater than 10bar must be located outside the fuel tank.

6.3.6 Any equipment included in the tank walls (air vents, inlets, outlets, tank fillers, inter tank connectors and access openings) must be metal or composite made fittings and must be bonded inside the fuel tank.

6.3.7 Fuel lines between the fuel tank and the homologated fuel flow meter must include a self-sealing breakaway valve, the parts of which must separate under a load less than half the load required to break the fuel line fitting or to pull it out of the fuel tank.

Fuel flow meter and fuel lines between fuel flow meter and fuel system must be insulated from heat coming from the power train.

6.3.8 Low pressure fuel lines must have a minimum burst pressure 2 times more than the maximum operating pressure of at a maximum operating temperature of 135°C.

6.3.9 High pressure fuel lines must have a minimum burst pressure 2 times more than the maximum operating pressure at a maximum operating temperature of 135°C.

6.3.10 Any device, system or procedure the purpose and/or effect of which is to increase the flow rate after the measurement point is prohibited.

~~The deposit of a complete system of fuel components located downstream of the FFM to the injectors included will be mandatory.~~

6.4 Fuel tank fillers and breather pipes

6.4.1 Fuel tank fillers must not protrude beyond the bodywork.

Any breather pipe connecting the fuel tank to the atmosphere must be designed to avoid liquid leakage when the car is running and its outlet:

- Must not be less than 250mm from the cockpit opening;
- Must be placed where they would not be vulnerable in the event of an accident;
- Must not protrude beyond the surface of the bodywork;
- Must be fitted with a non-return valve;
- May exit through the reference plane.

6.4.2 All fuel tank fillers and breathers must be designed to ensure an efficient locking action which reduces the risk of an accidental opening following a crash impact or incomplete locking after refuelling.

6.4.3 Cars must be fitted with combined fuel tank fillers and vents.

Fuel tank fillers must be able to be fitted each side of the car.

6.4.4 Both fillers and air vents must be equipped with leak proof dry break couplings complying with the dead man principle and therefore without any retaining device when in open position.

6.4.5 Couplings dimensions: Appendix J Drawing 252-5 (version B) exclusively.

6.4.6 At least one proximity sensor is mandatory to forbid the start of the ICE and any powering electrical motor while the coupling is connected to the car.

6.5 Refuelling

6.5.1 The refuelling equipment (with the car number affixed) and the tank of the car shall always remain at the outside ambient temperature and atmospheric pressure. It must always be in compliance with **Appendix A**.

6.5.2 No fuel intended for immediate use in a car may be more than ten degrees centigrade below ambient temperature. When assessing compliance, the ambient temperature will be that recorded by the FIA/ACO appointed weather service provider one hour before any practice session or two hours before the race. This information will also be displayed on the timing monitors.

6.5.3 The use of any device on board the car to decrease the temperature of the fuel is forbidden. Any device or system the purpose and/or effect of which is to increase the fuel storage capacity on board is prohibited. Any device or system whose principle is not strictly linked to gravity is prohibited.

6.6 Fuel Flow Metering - FFM

6.6.1 The use of one homologated fuel flow meter from FIA Technical List 45 is mandatory. It must be calibrated by a certified laboratory according to FIA Technical List 44.

6.6.2 The fuel flow meter must be placed before the high-pressure fuel pump on the feed line. The complete fuel flow feeding the high-pressure fuel pump must go through the fuel flow meter. Any fuel return will not be taken in account.

6.6.3 A FIA/ACO pressure sensor which directly measures the fuel pressure in the feed line of the main fuel flow meter is compulsory.

6.6.4 The installation of the FFM must be done in accordance with Article 13.15.

6.7 Fuel draining and sampling

6.7.1 Competitors must provide a means of removing all fuel from the car.

6.7.2 Competitors must ensure that a 1.0 litre sample of fuel may be taken from the car at any time during the Event.

After a practice session, if a car has not been driven back to the pits under its own power, it will be required to supply the above-mentioned sample plus the amount of fuel that would have been consumed to drive back to the pits. The additional amount of fuel will be determined by the FIA/ACO.

6.7.3 The car must be fitted with a self-sealing connector for sampling fuel.

This connector must be FIA approved (Technical list 5) and be fitted on the feed line to, and before, the high-pressure pump on the engine (it can be with the FFM connectors). If an electric pump on board the car cannot be used to remove the fuel an externally connected one may be used provided it is evident that a representative fuel sample is being taken. If an external pump is used it must be possible to connect the FIA/ACO sampling hose to it and any hose between the car and pump must be 3 in diameter and not exceed 2m in length.

6.7.4 The sampling procedure must not necessitate starting the engine or the removal of bodywork (other than the cover over the refuelling connector).

6.8 Fuel per stint

The mass of fuel used per stint must not exceed M (in kg), defined by the Endurance Committee.

ARTICLE 7: OIL AND COOLANT SYSTEMS AND CHARGE AIR COOLING

7.1 Power unit breather fluids

All power unit breather fluids may only vent to atmosphere. No breather fluids may re-enter the power unit.

7.2 Location of oil tanks

All oil storage tanks must be situated between the front wheel axis and the rearmost gearbox casing longitudinally, and must be no further than the lateral extremities of the survival cell are from the longitudinal axis of the car.

7.3 Longitudinal location of oil system

No other part of the car containing oil may be situated behind the complete rear wheels.

7.4 Transversal location of oil system

No part of the car containing oil may be more than 900 mm from the car centre plane.

7.5 Coolant header tanks

Coolant system pressure is limited to 4.75 barA when water-based coolant is used.

7.6 Cooling systems

The cooling systems of the power unit, including that of the air destined for combustion, must not intentionally make use of the latent heat of vaporisation of any fluid with the exception of fuel for the normal purpose of combustion in the engine as described in Article 5.7.3.

7.7 Oil and coolant lines

7.7.1 No lines containing coolant or lubricating oil may pass through the cockpit.

7.7.2 All lines must be fitted in such a way that any leakage cannot result in the accumulation of fluid in the cockpit.

7.7.3 No hydraulic fluid lines may have removable connectors inside the cockpit.

7.7.4 Low pressure lubrication oil lines must have a minimum burst pressure of 41 bars at a maximum operating temperature of 135°C.

7.8 Oil injection

The use of active control valves between any part of the PU and the engine intake air is forbidden.

7.9 Oil catch tank

7.9.1 The open type sump breather(s) (if any) must vent into a 3-litre minimum capacity catch tank.

7.9.2 In order to avoid the risk of oil being sprayed on the track, an additional secure tank of 1 litre minimum must be inserted between the catch tank and the air vent according to the drawing below.

7.9.3 The main function of this secure tank is to ensure that the breather of the catch tank contain no oil or oil vapor. If the oil vapors are treated properly upstream this secure tank, it must remain empty permanently.

7.9.4 ‡ The secure tank must:

- be separated from the catch tank,
- have 100 mm height (measured internally),
- have a constant section all along the height (with exception for a maximum 10mm radius in the bottom),
- be equipped with the sensor homologated by the FIA/ACO. This sensor must be implemented as shown on the drawing below in order to detect the oil overflow.

7.9.5 If the maximum level is reached, the competitor must enter immediately into his garage to drain the catch tank.

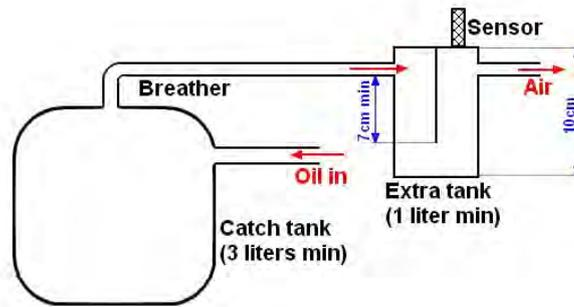

7.10 Hydraulic systems

7.10.1 Hydraulic Lines

Hydraulic system pressure is limited to 300 bar.

All hydraulic fluid lines must have a minimum burst pressure 2 times more than operating pressure at the maximum operating temperature of 204°C.

Only hydraulic fluid lines with self-sealing couplings or screwed connectors are permitted inside the cockpit.

The lines must be fitted in such a way that any leakage cannot result in accumulation of fluid in the cockpit.

Flexible lines must have swaged or crimped connectors and an outer braid resistant to abrasion and flame.

ARTICLE 8: ELECTRICAL SYSTEMS

8.1 Compliance and safety provisions

Closed-loop electronic control systems are forbidden unless expressly permitted by the present regulations. It is expressly allowed in the following cases:

- for any electrical motor (for example, but not restricted to: wiper motor, fuel pump, electrically controlled gear shift, etc);
- for engine (ICE) control;
- for MGU-K control respecting Article 5.5 and Article 5.6 requirements;
- for the alternator and the A/C system;
- for auxiliary electrical circuit management control (power box).

The FIA/ACO must be able to test the operation of any compulsory electronic safety systems at any time during an Event.

8.2 Auxiliary circuits and battery

8.2.1 The auxiliary battery (if fitted) must be located either in the cockpit in the place of the passenger or in the ES compartment and must be strongly secured. If in the cockpit, the battery must be entirely protected in a leak-proof box made of insulating material and in accordance with article 13.9.2. The battery fixation must be designed to withstand 70g deceleration in any direction.

8.2.2 The competitor must provide the power necessary (16 volts maximum) for the operation of the compulsory devices (Data logger, ADR, promoter information display, ...).

8.2.3 The auxiliary battery must never be used to recharge the traction battery. Throughout the duration of the event, the battery supplying the auxiliary electrical circuit must have a voltage below 60 volts.

8.2.4 The auxiliary circuit (network) consists of all the parts of the electrical equipment used to operate the internal combustion engine, for signaling, lighting or communication.

The parts used to operate the engine include but are not limited to: throttle, ignition, injection, intake, lubrication, fuel supply, cooling and turbo.

The equipment to start the engine and the HV ancillaries are excluded.

8.3 Lighting Equipment

Lighting equipment must always be in working order.

Cars must be fitted with:

8.3.1 At the Front:

8.3.1.1 Two main headlights as a minimum, homologated, symmetrical to the longitudinal centreline of the car and separated by a minimum of 1300 mm, the measurement being taken to the centre of the headlights; Headlights must produce a white beam.

8.3.1.2 Direction indicators on each side. Orange coloured, they must simultaneously flash when is applied the speed limitation for compliance with conditions of Slow Zones and Full Course Yellow.

A strategy for Slow Zones and Full Course Yellow speed limitation must be implemented in the car.

Flashing frequency of 4Hz (0.125 sec ON followed by 0.125 sec OFF). If the rain light is activated, the flashing should be in opposition of phase with the rain lights.

8.3.1.3 Identification light

No car identification lights may interfere with safety lights (ERS/medical) in positioning and in color (no variation of blue, red or green color).

As example and not limited to: behind the wind screen some similar colors will not be allowed. Inside the front lights compartment, any color will be allowed.

8.3.1.4 Main headlights cooling fan

A cooling fan is authorized per each headlight unit provided that:

- its only function is to adjust the temperature of the main headlight unit;
- the electrical power is less than 5 W;
- the fan outlet is within the bodywork.

8.3.2 At the Rear:

8.3.2.1 Two red lights and two "Stop" lights fitted symmetrically about the longitudinal centreline of the car and separated by a minimum of 1500 mm, the measurement being taken to the centre of the rear lights.

An alarm by flashing of the "stop" lights must be activated if loss of acceleration is greater than 0.4g within 0.2 second for at least 0.2 second.

The frequency of the flash to be achieved by 0.25sec ON ; 0.25 sec OFF.

Brake lights flashing must be deactivated when the car accelerates by more than 0.2g positive.

When triggered, flashing must be latched for a minimum of 2 seconds.

In any case Brake lights flashing must be deactivated as soon as brake pedal is pressed (goes to solid brake light on as normal when driver applies the brakes).

8.3.2.2 Two "Rain" or "Fog" lights located at the rear, the highest and outermost possible on each side symmetrically to the longitudinal centreline of the car.

They have to be homologated in accordance to FIA Standard 8874-2019 Grade 1(Technical List 46).

Both lights should have a flashing frequency of 4Hz (0.125 sec ON followed by 0.125 sec OFF).

Two levels of brightness modes must be implemented:

- Level High - full brightness mode for day time
- Level Low - reduced brightness mode for night

These two modes can be automatically linked to the high beam command, but the driver must be able to select it in case of exceptional request (heavy rain/fog during night, car running in high beam in case of low beam failure, ...).

To implement the two modes, the technical requirements are: Apply a pulse width modulation signal (PWM) at 300Hz frequency on the inhibit input, and use a duty cycle of 70% for day mode and 30% for night mode.

The side of the rain lights must be kept uncovered (no sticker, paint, etc.) in order to guarantee its cooling.

8.3.2.3 Direction indicators on each side. Orange coloured, they must simultaneously flash when is applied the speed limitation for compliance with conditions of Slow Zones and Full Course Yellow.

A strategy for Slow Zones and Full Course Yellow speed limitation should be implemented in the car.

Flashing frequency of 4Hz (0.125 sec ON followed by 0.125 sec OFF). If the rain light is activated the flashing should be in opposition of phase with the rain lights.

8.3.3 On the Sides:

A display module for timing information as described in Appendix to these Regulations must be fitted on each side of the car.

8.4 FIA/ACO Logging Requirements

The FIA/ACO mandatory logging sensors must be as described in the Appendixes to these Regulations.

All FIA/ACO logging sensors must be provided by the approved FIA/ACO supplier (Technical list 46). They must be directly connected to the FIA/ACO logger. Unless specified, the signal of these sensors will be sent to the competitor through CAN.

The FIA/ACO logging sensors wiring loom including the homologated flow meter and torque measuring units must be manufactured by the competitor and approved by the FIA/ACO.

The only allowed GPS is the FIA/ACO GPS from the mandatory logging system.

The FIA/ACO datalogger must be installed inside the cockpit, close to the ADR sensor to avoid possible cable damage in case of crash.

8.5 Data acquisition

The FIA/ACO must have unlimited access to the following ECU information before, during and after any track session:

- a) Application parameter configurations.
- b) Logged data and events.
- c) Real-time telemetry data and events.

Data acquisition is limited to permitted sensors.

The list of the sensors fitted in the car must be homologated, and all homologated sensors must be fitted in the car at all times. The only sensors permitted are listed in the Appendixes to these Regulations (There is no restriction on the number of each type unless stated).

8.6 Telemetry

8.6.1 The use of an FIA/ACO telemetry system is compulsory. No other telemetry system may be installed and/or used. A Standard logging table containing the channels listed in the Appendixes to these Regulations is mandatory.

8.6.2 The only communication between car and pits are as follows:

- Legible messages on a signaling pit board.
- The driver's body movements.
- Telemetry signals from the car to the pits via the FIA/ACO telemetry system.
- Two way verbal communications between the driver and his pit.

All such communication must be open and accessible to the FIA/ACO.

8.7 Track signal information display

All cars must be fitted with a compulsory marshalling display.

8.8 Safety Lights

Two safety lights LED's modules including the ERS status lights (if present) and the medical light provided by the approved FIA/ACO supplier (Technical list 46) must be installed on the car.

These modules must be located near the external extinguisher switch and visible on both sides of the bottom of the windscreen.

ARTICLE 9: ENGINE TRANSMISSION SYSTEM**9.1 Transmission types**

The engine transmission system must only drive the rear wheels and can be from a bespoke design.

	<ul style="list-style-type: none"> • if the original gearbox is used, it is not subject to Articles 9.2.1, 9.2.2, 9.2.5, 9.2.6, 9.5.1, 9.6.1, 9.6.4, 9.8.2. • No modifications are allowed to the original gearbox
--	--

9.2 Clutch

9.2.1 The following applies only to the rear power train clutch, any clutch used exclusively as part of front power train is exempt.

Only one clutch device is authorised for the combustion engine.

9.2.2 If multiple clutch operating devices are used, they must all have the same mechanical travel characteristics and be mapped identically.

9.2.3 Designs which allow specific points along the travel range of the clutch operating device to be identified by the driver or assist him to hold a position are not permitted.

9.2.4 The minimum and maximum travel positions of the clutch operating device must correspond to the clutch fully engaged normal rest position and fully disengaged (incapable of transmitting any useable torque) positions respectively.

9.2.5 Designs or systems which in addition to typical inherent hydraulic and mechanical properties are designed to, or have the effect of, adjusting or otherwise influencing the amount, or rate, of engagement being demanded by the ECU, are not permitted.

9.2.6 The amount by which the clutch is engaged must be controlled solely and directly by the driver with the exception of:

- a) Stall prevention.
- b) Gearshifts.

9.2.7 Any device or system which notifies the driver of the amount of clutch slip or engagement is not permitted.

9.3 Traction control

Cars may be equipped with a closed loop system or device which is capable of preventing the wheels from spinning under power or of compensating for excessive torque demand by the driver.

9.4 Clutch disengagement

All cars must be fitted with a means of disengaging the clutch for a minimum of fifteen minutes in the event of the car coming to rest with the engine stopped, making possible to push or to tow it. This system must be in working order throughout the Event even if the main hydraulic, pneumatic or electrical systems on the car have failed.

If a pneumatic assistance device is used, a compressed air bottle of a maximum capacity of 0.5 dm³ fitted outside the cockpit is allowed.

9.4.1 External neutral and general circuit breaker switches

See Article 14.16.

9.5 Gearbox

9.5.1 Only Aluminium or Magnesium alloy casings and bellhousing are allowed.

9.5.2 The minimum weight of the gearbox is 75 kg, considering the weight perimeter described in Appendix 2.

9.5.3 The minimum CoG height of the gearbox in the above conditions is 150 mm above reference plane.

9.6 Gear ratios

9.6.1 The number of forward gear ratios must be no more than 7.

9.6.2 No more than 2 different sets of gear ratios may be homologated.

9.6.3 Gears must be made from steel.

9.6.4 Any system that permits more than one gear pair to be engaged to the drivetrain at any one time is prohibited.

9.7 Reverse

The car must be able to be driven in reverse by the driver at any time during the Event.

9.8 Gear changing

9.8.1 Automatic gear changes are considered a driver aid and are therefore not permitted.

For the purposes of gear changing, the clutch and power unit torque may not be under the control of the driver.

9.8.2 Instantaneous gearshifts are forbidden.

Gearshifts have to be distinct sequential actions where the extraction of the actual gear engagement is subsequently followed by an insertion of the target gear engagement.

Only one single barrel shift mechanism or one H-pattern gearshift mechanism is permitted.

The gearshift mechanism has to operate all forward gears, the reverse gear may be operated by a separate actuation system.

A consequent engine cut must be applied for a minimum of 30 ms. (Consequent meaning that the average over 30ms of the sum of the torques given by the 2 driveshaft torque sensors connected to the engine is lower than 50% of the torque given by the same torque sensors just before the cut happens).

9.8.3 Continuously variable transmission systems are not permitted to transmit the power of the power unit defined in Article 5.1.

9.8.4 Each individual gear change must be separately initiated by the driver and, within the mechanical constraints of the gearbox, the requested gear must be engaged immediately unless over-rev protection is used to reject the gear shift request. Once a gear change request has been accepted no further requests may be accepted until the first gear change has been completed.

Multiple gear changes may only be made under Article 5.16 or when a shift to gearbox neutral is made following a request from the driver.

If an over-rev protection strategy is used this may only prevent engagement of the target gear, it must not induce a delay greater than 50 ms. If a gear change is refused in this way, engagement may only follow a new and separate request made by the driver.

Any de-bounce time used to condition driver gear change requests must be a single and constant value.

9.8.5 Distance channel or track position is not considered an acceptable input to gearbox control.

9.9 Torque transfer systems

Any system or device the design of which is capable of transferring or diverting torque from a slower to a faster rotating wheel is not permitted, except those described in Article 9.10.

9.10 Differential

Only Mechanical limited slip differentials working without the help of a hydraulic/pneumatic or electric system are allowed.

A visco-coupling system is not considered as a hydraulic slip control device provided that no control is possible when the car is running.

ARTICLE 10: SUSPENSION AND STEERING SYSTEMS

10.1 Suspension design and geometry

10.1.1 Cars must be fitted with sprung suspension.

10.1.2 Any suspension system fitted to the front wheels must be so arranged that its response results only from changes in load applied to the front wheels.

10.1.3 Any suspension system fitted to the rear wheels must be so arranged that its response results only from changes in load applied to the rear wheels.

10.1.4 Any system the purpose of which is to hydraulically link shock absorbers and/or the 3rd suspension element is forbidden.

10.1.5 Double wishbones is the only suspension kinematic allowed.

10.1.6 No more than three shock absorbers per axle are allowed.

10.1.7 The following systems are forbidden:

- Mass damper: Moving mass linked to the wheel located on the sprung weight with the sole objective of tuning the natural frequency of the suspension.
- Inerter damper: Rotating mass linked to the wheel located on the sprung weight with the sole objective of tuning the natural frequency of the suspension.
- G-damper: Moving mass located on the sprung weight with the sole objective of controlling the suspension depending on acceleration.

10.2 Suspension adjustment

10.2.1 No adjustment may be made to any suspension system from inside the cockpit.

10.2.2 Any system, other than the suspension parts, whatever the functioning principle, activated or not by the driver the purpose of which is to modify the ground clearance is forbidden.

10.2.3 Electrically controlled shock absorbers are forbidden.

10.2.4 The car must be used on track within the following ride height limits:

- 110 mm maximum dynamic axle ride height (front and rear)
- 100 mm maximum static ride height (front and rear)

FIA/ACO will police these figures by checking the static ride heights and the suspension droop at scrutineering.

However, additional ride height measurement on track is required (Lasers, RH modelling based on hub displacement and pushrods, ...).

If, when required for checking, a car is not already fitted with dry-weather tyres inflated to 2.0 +/-0.1 bar gauge pressure, or the condition of the tyres which are fitted is not suitable, a suitable set of dry-weather tyres may be selected by the FIA/ACO technical delegate.

10.3 Suspension members

10.3.1 One non-structural part is allowed on each suspension arm providing that:

- it is used to protect the suspension member, the brake lines, wheel tethers or electrical wires;
- the width/height ratio of its cross section does not exceed 3 per arm;
- the shape of the part is symmetrical, referred to the cross section perpendicular to the suspension arm;
- the maximum thickness of its cross section is equal to the maximum height of its cross section of the suspension arm on which the part is fixed +4 mm;
- it may be split in 2 parts with the only purpose of allowing its fitting/unfitting from the suspension arm.

10.3.2 The suspension members must:

- be made from an homogeneous metal

- not be chromium plated
- have a profile which width/height ratio does not exceed 3.0
- be mandatorily fitted with an anti-intrusion bar at the base of the front suspension wishbones if these are potentially dangerous for the driver's legs.

10.4 Steering

10.4.1 The design and geometry of the steering system are free, provided that there is a continuous mechanical link between the steering wheel and the front wheels of the car.

10.4.2 Steering column

The steering column must be approved by the FIA in accordance with the approval procedure of safety structures for sports cars.

10.4.3 No part of the steering wheel or column, nor any part fitted to them, may be closer to the driver than a plane formed by the entire rear edge of the steering wheel rim. All parts fixed to the steering wheel must be fitted in such a way as to minimise the risk of injury in the event of a driver's head making contact with any part of the wheel assembly.

10.4.4 Four-wheel steering is forbidden.

10.4.5 Power steering is allowed but such system may not carry out any function other than reduce the physical effort required to steer the car and must allow the steering to continue to function when all hydraulic and/or electric power is shut down.

10.4.6 A quick release system of the steering wheel is mandatory.

The quick release mechanism must consist of a flange concentric to the steering wheel axis, coloured yellow through anodization or any other durable yellow coating, and installed on the steering column behind the steering wheel.

The release must be operated by pulling the flange along the steering wheel axis.

The release of the steering wheel must open the power circuit.

ARTICLE 11: BRAKE SYSTEM

11.1 Brake circuits and pressure distribution

11.1.1 With the exception of a power unit, all cars must be equipped with only one brake system. This system must solely be comprised of two separate hydraulic circuits operated by one pedal, one circuit operating on the two front wheels and the other on the two rear wheels. This system must be designed so that if a failure occurs in one circuit the pedal will still operate the brakes in the other. The only connection allowed between the two circuits is a mechanical system for adjusting the brake force balance between the front and rear axles.

11.1.2 The brake system must be designed in order that the force exerted on the brake pads within each circuit are the same at all times.

11.1.3 Any powered device, other than the system referred to in Article 11.7, which is capable of altering the configuration or affecting the performance of any part of the brake system is forbidden.

11.1.4 Any change to, or modulation of, the brake system whilst the car is on the track must be made by the driver's direct physical input or by the system referred to in Article 11.7, and may not be pre-set.

11.1.5 Sensors to collect information, stop lights switches or mechanical brake pressure controls adjustable by means of tools are not considered as "systems" and they must be fitted at the exit of the master-cylinders.

11.1.6 No device or system is permitted between the master-cylinders and the callipers, except for the system described in Article 11.7.

11.2 Brake callipers

11.2.1 All brake callipers must be made from aluminium materials with a modulus of elasticity no greater than 80Gpa.

11.2.2 No more than two attachments may be used to secure each brake caliper to the car.

11.2.3 No more than one caliper, with a maximum of six pistons, is permitted on each wheel.

11.2.4 The section of each caliper piston must be circular.

11.3 Brake discs and pads

11.3.1 No more than one brake disc is permitted on each wheel which must have the same rotational velocity as the wheel it is connected to.

11.3.2 All discs must have a maximum outside diameter of 381 mm.

11.3.3 The number of ventilation holes per disc is limited to 500.

11.3.4 No more than two brake pads are permitted on each wheel.

11.4 Brake cooling ducts

Brake cooling ducts around the front and rear brakes are considered part of the braking system and shall not protrude beyond:

- a) A plane parallel to the ground situated at a distance of 220 mm above the horizontal centre line of the wheel.
- b) A plane parallel to the ground situated at a distance of 220 mm below the horizontal centre line of the wheel.
- c) A vertical plane parallel to the inner face of the wheel rim and displaced from it by 100 mm toward the car centre plane.
- d) A vertical plane parallel to the center plane of the disc and displaced from it by 80 mm (100 mm around the brake calliper) in opposite direction of the car centre plane.

Furthermore:

- e) When viewed from the side the ducts must not protrude forwards beyond a radius of 380 mm from the centre of the wheel or backwards beyond a radius of 220 mm from the centre of the wheel.
- f) The ducts may not rotate with the wheels.

- g) No part of the car, other than those specifically defined in Article 12.7.1 and Article 12.7.2, may obscure any part of the wheel when viewed from the outside of the car towards the car centre plane along the axis of the wheel.
 - h) A brake drum is also considered as a brake cooling duct.
 - i) Brake cooling flexible hoses are allowed and not considered as brake cooling ducts for the purpose of this article.
- All measurements will be made with the wheel held in a vertical position.

11.5 Brake pressure modulation

11.5.1 No braking system may be designed to prevent wheels from locking when the driver applies pressure to the brake pedal.

11.5.2 Any power braking function is forbidden, except for the system described in Article 11.7.

11.6 Liquid cooling

Liquid cooling of the brakes is forbidden.

11.7 Front brake control system

If the car is fitted with an MGU-K connected to the front wheels, the pressure in the front braking circuit may be provided by a powered control system provided that:

- a) The driver brake pedal is connected to a hydraulic master cylinder that generates a pressure source that can be applied to the Front braking circuit if the powered system is disabled.
- b) Ensure a design of the braking system that can achieve similar deceleration levels to normal operation when calipers are activated only by the force applied by the driver on the brake pedal without any further braking power coming from the MGU-K system or from any hydraulic high-pressure brake devices, in order to ensure safety should there be a failure of the electrical system.
- c) Have no closed-loop control on the wheel slip.

ARTICLE 12: WHEELS AND TYRES**12.1 Location**

As viewed from above and front, the wheels aligned for the car to proceed straight ahead, the complete wheels and their attachment must not be visible above the horizontal plane passing through the axle centreline.

12.2 Number of wheels

The number of wheels is fixed at four.

Only one specification on the front and one on rear axle is allowed.

12.3 Complete wheel dimensions (rim and tire)

12.3.1 Complete wheel diameter must not exceed 28".

12.3.2 Complete wheel width and diameter will be measured horizontally at axle height, with the wheel held in a vertical position and when fitted with new tyres inflated to 1.4 bar.

12.3.3 Tyre dimension and maximum complete wheel width must be according to the following table:

	Option 1		Option 2	
	F	R	F	R
Tyre dimension	31/71-18	31/71-18	29/71-18	34/71-18
Max. complete wheel width	14"	14"	13.5"	15"

12.4 Wheel material

Wheels must be made from homogeneous alloy.

It must be produced as integral part, without welding and/or cavities.

12.5 Wheel dimensions (rim)

12.5.1 Wheel maximum width must be according to the following table:

	Option 1		Option 2	
	F	R	F	R
Tyre dimension	31/71-18	31/71-18	29/71-18	34/71-18
Max. complete wheel (rim) width	13"	13"	12.5"	14"

12.5.2 Wheel diameter must not exceed 18".

12.5.3 Wheel weight must be greater than:

Wheel (rim) dimension	Weight:
12.5"	8.75 kg
13"	9 kg
14"	9.25 kg

12.5.4 Wheel must comply with the following specifications:

- ~~Wheel edges must be symmetrical and t~~The diameters measured at the level of the inner and outer rim edges of a wheel must be identical, with a tolerance of +/- 1.5 mm; It must not be more than 19.2 mm maximum in height.
- The design of the wheel must meet the general requirements of the tyre supplier for the mounting and dismounting of tyres including allowance for sensors and valves.
- The wheel design cannot be handed between left and right designs.

12.5.5 When fitted on the car every part of the complete wheel assembly has to turn at rim speed.

12.5.6 When viewed perpendicular to the plane formed by the outer face of the wheel and between the diameters of 150 mm and 400 mm the wheel may have projected area of no greater than 46 000 mm².

12.6 Treatment of tyres

Tyres may only be inflated with air or nitrogen.

12.7 Wheel assembly

12.7.1 The only parts which may be physically attached to the wheel in addition to the tyre are surface treatments for appearance and protection, valves for filling and discharging the tyre, wheel fasteners, balance weights, drive pegs, tyre pressure and temperature monitoring devices and spacers on the inboard mounting face of identical specification on all wheels for the same axle.

For the avoidance of doubts, removable wheel/hub caps are not permitted.

12.7.2 The wheel must be attached to the car with a single fastener. The outer diameter of the fastener must not exceed 110 mm and the axial length must not exceed 75 mm. The wheel fastener may not attach or mount any part to the car except the wheel assembly described in Article 12.7.1.

12.7.3 A complete wheel must contain a single fixed internal gas volume. No valves, bleeds or permeable membranes are permitted other than to inflate or deflate the tyre whilst the car is stationary. Pressure control valves are not permitted.

12.7.4 Devices which are used to fit or remove wheel fasteners may only be powered by compressed air or nitrogen. Any sensor systems may only act passively.

12.8 Pneumatic jacks

Permitted. However, on the starting grid, the coupling function to connect the air hose onto the air jacks must have a system that maintains the car on the air jacks when the air hose is removed.

It is forbidden to carry on board compressed air bottles for their operation.

12.9 Dimension of tyres

No more than 3 different tyre dimensions will be made available by the appointed tyre supplier.

Tyre dimensions choice must be homologated for each car, respecting the condition above:

ARTICLE 13: COCKPIT AND SURVIVAL CELL

13.1 Principles

The cockpit must provide the best protection for the driver.

The cockpit must be designed in such a way that any leakage cannot result in accumulation of fluid in it.

It must be possible to fit a driver’s seat (see Drawing 14B) and the mandatory protections mentioned in Article 14.6 (Headrest) and Article 15.2.1 (Survival cell - General prescription).

The roll-over structures/supports of the survival cell must be symmetrical with respect to the car centerline.

13.2 Bottom plane of the survival cell

Two ‘datum’ pads of 80 mm diameter must be located at the bottom of the survival cell. They should be positioned at least at 350 mm from car centreline on each side and be validated by FIA/ACO before the survival cell manufacturing. They must be attached to the survival cell so that their bottom face is at the survival cell reference plane. The distance between the bottom plane of the survival cell (survival cell reference plane) and the reference plane must be homologated. A M5 thread in the middle of each ‘datum’ pad must provide mean of easy access during scrutineering.

A ‘datum’ pad of 80 mm diameter must be positioned on the car centerline underneath the bellhousing or the gearbox to provide structural reference (typically in the same plane as the survival cell ‘datum’ pads). A M5 thread in the middle of the ‘datum’ pad must provide mean of easy access during scrutineering (removal of a 80 mm diameter part of the skid block will be possible).

The bottom plane of the survival cell structure must include a rectangle of 700 mm (longitudinally) x 800 mm (laterally).	
---	--

13.3 Position of the driver’s feet

The face of the foremost pedal, when in the operative position, must be situated no less than 300 mm rearward of the survival cell bulkhead and rearward of the front wheel centre line.

The foremost pedal position is to be considered for throttle pedal at full power position.

Drawing of pedals in relation to inserts in cockpit to be supplied for homologation of the car.

13.4 Position of the steering wheel

The reference for the steering wheel will be the intersection of:

- steering wheel plane (passing through the centre of the zone of driver hands grip);
- the steering column axis.

The centre of the steering wheel must match with:

The centreline of driver’s seat. The steering wheel center shall be positioned at 150 mm minimum from car centreline. The top of the steering wheel should be positioned at least 650 mm above Zref plane.	The centreline of driver’s seat.
The edge of the dashboard must be at a minimum of 50 mm from the complete steering wheel, whatever its operational position (should the collapsable part of the steering column be shorter by 50 mm, no part of the steering wheel should get in contact with the dashboard).	

13.5 Driver's position in relation with the field of visibility

The foremost point of the padding of the headrest at the level of the contact with rear face of helmet must be at 85 mm (or 95 mm in case of additionnal padding as described in Article 14.6.2) forward Xref plane;	
The driver at the wheel, the top of the helmet must be between 80 mm and 100 mm from any line situated in a X-Z plane connecting the top of front and rear rollover structures over the helmet.	

13.6 Volumes for the driver and passenger legs – Template H2

13.6.1 Geometrical definitions

<p>Two identical volumes must be provided for the legs of both occupants. Their lower faces must lie on the same plane, be parallel to the reference surface and cannot be located more than 150 mm above Zref plane. Their inboard vertical planes must be symmetrical to the centre plane of Template H3 and not overlapping.</p> <p>The dimensions of the driver volume must be:</p> <ul style="list-style-type: none"> • In length (X axis): from the foremost position of the driver's feet described in Article 13.3 to the steering wheel reference described in Article 13.4. • In width (Y axis): minimum 330 mm; • In height (Z axis): minimum 350 mm. 	<p>One volume must be provided for the legs of the driver.</p>
---	--

13.6.2 Equipment permitted in these volumes

<p>All allowed parts to intrude inside the leg template should not present radius of less than 15 mm except for the complete pedal system and associated parts.</p> <p>The area between 1100 mm and 800 mm forward of Xref plane must remain free except for the protective foam on the driver side. The only components allowed to intrude into these volumes and outside of the area above, are:</p> <ol style="list-style-type: none"> a) The steering column and its universal joints; b) The pedals, related looms, foot-rest and pedal adjustment system; c) The suspension arms pick-up points if not a danger for the driver; d) The windscreen wiper mechanism and its motor; e) Equipment needed for driving fitted on a panel that must be removable; f) Driver leg padding; g) Driver leg padding support on the passenger side; h) Auxiliary batteries in compliance with Article 8.2 into the volume for the passenger; i) The ES to ERS compartment into the volume for the passenger; j) The ERS can intrude into the passenger leg Template H2; k) The driver's seat (Article 14.10) <p>However, components c), d), e) above are not allowed in The area between 1100 mm and 800 mm forward of Xref plane on the driver's side. Nothing is allowed to protrude into the interior of the empty volume of the driver side padding (see Drawing 13A).</p>	
---	--

13.7 Volume for the driver and the passenger bodies – Template H3

<p>The cockpit (doors closed) must allow the insertion of the Template H3.</p> <p>The dimensions and position the Template H3 are defined by Drawing 13C and Drawing 13I.</p> <p>The rearmost point of the template H3 must be at 20 mm forward Xref plane. The upper face of the template must be horizontal and at 500 mm from Zref plane.</p> <p>For this check, equipment mentioned in Article 13.9 may be removed.</p> <p>All the points of the survival cell that delimit Template H3 at the sides, front and rear must be at least 500 mm above Zref plane.</p>	
--	--

13.8 Volume for the driver and the passenger heads – Template H4**13.8.1 Geometrical definitions for the driver and the passenger heads**

<p>The cockpit (doors closed) must allow the insertion the Template H4. The dimensions and position of the Template H4 are defined by Drawing 13D and Drawing 13I.</p> <p>The back face will be positioned 20 mm forward Xref plane. Its bottom faces must be parallel to the survival cell reference plane and at least 520 mm above Zref plane.</p> <p>For this check, equipment mentioned in Article 13.9 may be removed.</p>	
--	--

13.9 Equipment in the cockpit**13.9.1** Are permitted

only outside the two volumes defined in Ar.13.6	
---	--

- safety equipment and structures which are not part of the survival cell,
- tool kit,
- seat(s),
- driving controls,
- electronic equipment,
- drink system,
- ballast,
- jacks,
- ventilation ducts,
- door locking mechanism.

13.9.2 The auxiliary batteries are permitted in the cockpit. These components must be covered by a rigid and efficient protective material in the event of a crash if a danger for the driver.

13.9.3 Nothing may hinder the cockpit exit (see Article 13.10.3).

13.9.4 The way the equipment permitted is fitted in the cockpit is subject to FIA/ACO Technical Delegates assessment. All fittings must be able to withstand 25g deceleration in any direction.

13.9.5 Are permitted but only outside the driver volume defined in Article 13.6 and respecting Article 13.11:

- driver cooling system,
- ventilation ducts.

13.10 Cockpit access**13.10.1 Principles**

The driver must be able to enter and get out of the cockpit without it being necessary to remove any part of the car other than the steering wheel and opening the door. When exiting from the passenger side, the headrest may also be removed.

The driver, seated normally with his seat belts fastened and with the steering wheel removed must be able to raise both legs together so that his knees are past the plane of the steering wheel in the rearward direction. This action must not be prevented by any part of the car.

13.10.2 Door openings

<p>In order to ensure that the door openings giving access to the cockpit are of adequate size, they must:</p> <ul style="list-style-type: none"> • Allow the insertion of the Template H6, the dimensions and position of which are defined by Drawing 13F and Drawing 13I; • For this test, the lower surfaces of the templates will be held parallel to the reference surface, at 	
--	--

<p>the same height, and their rear edges aligned transversally;</p> <ul style="list-style-type: none"> • The rearmost face of the templates will be positioned at 120 mm from Xref plane; • The driver templates will be moved transversally until their flat vertical inner surfaces are 150 mm from the car centreline; • The passenger Template will be the symmetry of the driver Template from the car centreline; • The lower face will be positioned at least 500 mm above Zref plane; • The seat and all padding, including fixings, may be removed, as well as the doors. 	
---	--

13.10.3 Cockpit exit time

The cockpit must be designed so as to allow the driver wearing his complete driving equipment, being seated in a normal position with the seat belts fastened and the steering wheel in place to get out in 7 seconds maximum (driver's side) and in 9 seconds maximum (passenger's side).

13.10.4 Test for helmet removal

With the driver seated in his normal driving position in the car which he is entered to race, wearing a cervical collar appropriate to his size and with the seat harness tightened, a member of the medical service must demonstrate that the helmet which the driver will wear in the race can be removed from his head without bending the neck or spinal column.

	A removable roof hatch may be provided for in order to achieve the test above.
--	--

13.11 Driver's field of frontal visibility

13.11.1 Geometrical definition

The visibility from the cockpit with the driver seated in racing position must:

<p>be in compliance with the following requirement: The cockpit must allow the insertion of the Frontal Visibility Template V1 (defined by Drawing 13G and Drawing 13J) through the windscreen opening. Its rear vertical face must coincide with the forward vertical face of Template H4. The centre plane of the volume must be at car centreline. The lower edge of its rear vertical face must be positioned at least at 585 mm above Zref plane.</p>	Respect the original car visibility except for achieving compliance with the present regulations.
--	---

13.11.2 Equipment restriction

The only components allowed to intrude in this area, are:

- the windscreen and windscreen wiper;
- the antennas and pitot tubes;
- the air ducts for the cockpit ventilation, with a maximum height of 40mm in front vision. Their outlets may not minimize front vision of the driver;
- Marshalling Display and driver's display (within same height of Marshalling Display);
- the rear view camera display;
- the FIA/ACO high speed camera.

13.12 Driver's field of lateral visibility

13.12.1 Geometrical definition

The visibility from the cockpit with the driver seated in racing position must:

<p>Be in compliance with the following requirement: The cockpit must allow the insertion of the Lateral Visibility Template V2 (defined by Drawing 13H and Drawing 13J) through the side windows.</p>	Respect the original car visibility except for achieving compliance with the present regulations.
---	---

<p>The rear vertical face must be positioned at 121 mm from Xref plane. The inner face of both volumes must be in contact with Template H4.</p>	
---	--

13.12.2 Equipment restriction

<p>Excepted the padding and support for the driver's head, the rear-view mirrors and the door hinges/mechanisms, no bodywork is permitted in these two volumes. The projection of the volumes representing the intersections between the rear-view mirrors (with supports) and the side visibility templates on the car longitudinal plane (plane X-Z) should have an area less than 150 cm² per mirror projected.</p>	
---	--

13.13 Cockpit temperature

The ambient temperature will be displayed by the official timing monitors. It will be measured in the shade and out of the wind.

An effective natural and/or forced ventilation and/or air conditioning system must maintain the temperature around the driver when the car is in motion at:

- 32 °C maximum when the ambient temperature is less than or equal to 25°C;
- a temperature less than or equal to ambient temperature +7°C if it is above 25°C.

These temperature criteria should be respected in less than 8 minutes after a car stop.

It is permitted to have air flow adjustment accessible from the driver.

A homologated temperature sensor is imposed inside the cockpit at Z810 and on the centreline of the car. The sensor must be shielded from direct draught as per following drawing:

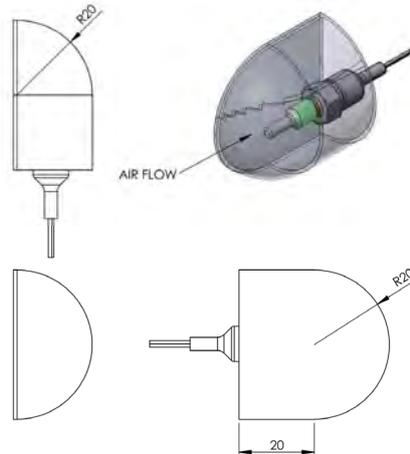

13.14 Fuel tank compartment

The complete fuel tank must be positioned inside the survival cell and behind:

<p>the Template H3.</p>	<p>The driver and passenger seats.</p>
-------------------------	--

This compartment must be entirely sealed with the cockpit and a fireproof bulkhead must separate the fuel cell and fuel lines from the cockpit and the engine compartment.

Any holes in the fireproof bulkhead must be of the minimum size for the passage of controls and cables, and must be completely sealed.

The minimum useable fuel tank volume must allow the car to make 12 laps to the Le Mans circuit.

13.15 Fuel Flow Metering installation volume

13.15.1

A volume with minimum dimensions must be provided for installation of the Fuel Flow Meter in a position that is not at risk in case of crash.

Whatever the dimensions of the installation volume, articles 13.15.2 and 13.15.3 must be fulfilled at any time.

13.15.2 This equipment must be able to be exchanged individually, quickly in case of failure. A change during a session (race included) could be required at the discretion of the FIA/ACO.

13.15.3 This equipment must be ventilated by air coming directly from the outside of the car and exiting outside the car in order to provide a temperature as close as the ambient. The temperature of the fuel flow meter body will be recorded.

13.16 ES compartment

If present, the ES must be positioned

inside the survival cell behind the Templates H3.	in the original position or inside the survival cell behind driver and passenger seats.
---	---

The ES must be accessible from the bottom of the survival cell. This compartment must be entirely sealed with the cockpit and the fuel tank compartment

The ES should be fixed or integrated to the ES closing panel. This panel must be attached to the survival cell and ensure sufficient protection to the ES.

13.17 ERS compartment

If present, the ERS must be positioned:

inside the survival cell	in the original position or inside the survival cell
--------------------------	--

This compartment must be entirely sealed from the cockpit. The separation panels with the cockpit may be removable but must be able to withstand 1kN load with less than 2 mm of deformation.

13.18 ES to ERS compartment

An ES to ERS compartment must be entirely sealed **with from** the cockpit and the fuel tank compartment.

All the separation panels must be tested according to the safety test described **for the ES compartment** in the Appendixes to these Regulations.

13.19 Survival cell identification

Every survival cell must incorporate three transponders described in the Appendixes to these Regulations for identification purposes. These transponders must be a permanent part of the survival cell, be accessible for verification at any time and be positioned as follow (+/- 60 mm):

- On the top of the survival cell, in line with the front axle and on the car centreline;
- Inside the cockpit on left hand-hand side, in line with the foremost point of the door opening and at 100 mm from the bottom of the door opening;
- Inside the cockpit on right hand-hand side, in line with the foremost point of the door opening and at 100 mm from the bottom of the door opening.

13.20 Survival cell characteristics

13.20.1 The minimum weight of the survival cell is 90 Kg, considering the weight perimeter described in Appendix 3.

13.20.2 The minimum CoG height of the survival cell in the above conditions is 370 mm above Zref plane.

ARTICLE 14: SAFETY EQUIPMENT**14.1 General**

As a general principle, it is the duty of the manufacturer and/or competitor to demonstrate that the car is of safe construction.

A device must prevent powered movement of the vehicle whenever the driver is not fully seated in the driver's seat.

Any type of adhesive covering the lever of a switch or a push button for Safety is strictly forbidden.

14.2 Fire extinguishers

14.2.1 All cars must be equipped with an extinguishing system in compliance with FIA Standard 8865-2015.

The system must be used in accordance with the manufacturer's instructions and with Technical List n°52, and in accordance with Appendix J - Article 253-7.2 except as regards the means of triggering.

14.2.2 Any triggering system having its own source of energy is permitted, provided it is possible to operate all extinguishers should the main electrical circuits of the car fail.

The driver must be able to trigger the extinguishing system manually when seated normally with his safety belts fastened and the steering wheel in place.

Furthermore, a means of triggering from the outside must be combined with the circuit breaker switches described in Article 14.16. They must be marked with a letter "E" in red at least 80 mm tall, with a line thickness of at least 8 mm, inside a white circle of at least 100 mm diameter with a red edge with a line thickness of at least 4 mm. This identification must be self-reflecting.



There must be two external switches, that must:

- be located, one on each side of the car symmetrically to the car centre line, below a line under Z dashboard +40 mm, in front of the A-Pillar and fixed to the survival cell;
- be less than 350 mm from the door openings;
- be designed such that a marshal is unable to accidentally reenergise the power circuit,
- be fitted with a horizontal handle or ring that can be operated from a distance by a hook.

14.2.3 All extinguisher nozzles must be installed in such a way that they are not directly pointed at the driver.

14.3 Drivers Master switch

14.3.1 The driver, when seated normally with the safety belts fastened and the steering wheel in place, must be able to cut off the electrical circuits to the ignition, all fuel pumps, and the ERS System by means of a spark proof circuit breaker switch.

The switch must be mechanically protected against accidental engaging.

This switch must be located on the dashboard and must be clearly marked by a symbol showing a red spark in a white edged blue triangle.

The operation is specified in Appendix J – Article 253-18.16 (Except the "creep" control) and in Drawing N°10.

Drawing N°10 is for illustrative purposes, the detail and layout is upto the competitor, however the following electrical states must be possible:

P0 – All car electrical power is off

P1 – Main power is supplied but the vehicle is unable to move (ES and Engine not powered)

P2 – The car is able to move (front and rear day-light position lights ON)

14.4 Rear view mirrors

14.4.1 All cars must have two mirrors mounted so that the driver has visibility to the rear and both sides of the car.

14.4.2 The reflective surface of each mirror must be greater than 100 cm².

14.4.3 The FIA/ACO technical delegates must be satisfied by a practical demonstration that the driver, when seated normally, can clearly define following vehicles.

For this purpose, the driver shall be required to identify any letter or number, 75 mm high and 50 mm wide, placed anywhere on boards behind the car, the positions of which are detailed below:

- Height : From 400 mm to 1000 mm from the ground.
- Width : From 0 to 5000mm either side of the car centre plane.
It will be permitted to use rear view camera from 0 mm to 2000 mm.
- Position : 5 m behind the rear wheel centre line.

14.4.4 There must be a day/night mode for the rear-view mirrors. It may be done with a film.

14.4.5 It is permitted to add cameras on the car and screens inside the cockpit for rear and front/side vision. Cameras and screens must have a day/night mode.

The cameras are allowed to protrude over the maximum height of the car at the condition that a specific allowance is given during Homologation of the car. The purpose of their design cannot be to provide any aerodynamic benefit.

14.5 Safety belts

Safety belt mounting points must be approved by the FIA in accordance with the procedure for the approval of safety structures for sports cars.

The shoulder belts anchorage must be installed such that they provide to the belts a recommended angle between 0 and 5° (down) in reference with horizontal when the driver is seated in racing conditions.

The shoulder belt anchorage points on the car shall be symmetrical about the centre line of the driver’s seat. When viewed from above, it is recommended that the converging angle between the belts be approximately 20°-25° and never out of the 10°-25° range.

Safety belts in compliance with FIA Standard 8853-2016 (Technical List n°57) are compulsory.

Straps must be securely fixed to the car.

A single kit of safety belts must be used according to Appendix J - Article 253.6.3.

14.6 Cockpit head padding

14.6.1 All cars must be equipped with an area of padding for the driver’s head which:

a) must respect the dimensions from Drawing 14A.

b) must have its lower horizontal surface positioned 565 mm from Zref plane.	
--	--

c) must be centered with the seat.

d) Are so arranged that they can be removed from the car as three parts (driver’s door, behind the driver and the rearmost side part, the foremost side part).

e) The rear part of the headrest must be located by two horizontal pegs and two quick release fixings, which are clearly indicated and easily removable without tools. No tape or similar material may be used to cover the fixings of the headrest.

f) Are made from a material featuring in the FIA Technical List 17 (Headrest materials for Sports Cars).

g) Are covered, in all areas where the driver’s head is likely to make contact, with two plies of Aramid fibre/epoxy resin composite pre-preg material in plain either both consisting of 60 g/m² fabric, or consisting of one 60g/m² fabric and one 170g/m² fabric, with a cured resin content of 50% (+/-5%) by weight.

h) No surface treatment on aramid cover is permitted except paint and additional flock spraying on the contact surface to the helmet. The used product must be capable to minimize the friction of the surface when in contact with the helmet.

i) must not present discontinuity area of material (removal parts, door) more than 10 mm between all parts

j) must have no recess for the Frontal Head Restraint device.

k) If it is necessary to design the lateral part on passenger side as mobile, at least one proximity sensor is mandatory to forbid the start of the ICE and any powering electrical motor unless the protection is in full safe and locked position.

l) must be approved by the FIA in accordance with the approval procedure of safety structures for sports cars. The minimum notice is 8 weeks from the foreseen test dates.

14.6.2 The first area of headrest for the driver’s head must be positioned behind him and be 85 mm thick. If necessary, and only for driver comfort, an additional piece of padding no greater than 10mm thick may be attached to this headrest provided it is made from the same material which incorporates a low friction surface.

14.6.3 The second area of padding for the driver's head must be positioned on both sides and be 85 mm thick. If necessary, and only for driver comfort, an additional piece of padding no greater than 20mm thick may be attached to this headrest provided it is made from the same material which incorporates a low friction surface. Furthermore, any void between these areas of padding and the area described in Article 14.6.2 must also be completely filled with the same material.

Adaptation of the section of the forward lateral parts will be allowed in the area described "ZONE ARM" (Drawing 14A) providing that in any vertical transversal section a minimum area of 1500 mm² is respected.

14.6.4 All of the padding described above must be so installed that if movement of the driver's head, in any expected trajectory during an accident, were to compress the foam fully at any point, his helmet would not make contact with any structural part of the car.

14.7 Cockpit leg padding

14.7.1 In order to minimise the risk of leg injury during an accident, additional areas of padding must be fitted each side of, and above, the driver's legs.

The vertical transversal minimum section on driver side must conform to Drawing 13A.

14.7.2 These areas of padding must:

- a) Be made from a material featuring in the FIA Technical List 17 (Headrest materials for Sports Cars).
- b) Be no less than 25mm thick over their entire area.
- c) Extend between 100 mm rearward from rearmost position of the pedals (foot pad) and 150 mm forward of the steering wheel reference described in Article 13.4.
- d) Cover the height described in Article 13.6.1.
- e) Support a load of 7KN applied in the Y axis from the free leg volume outwards.

Local modifications and/or trimming of the cockpit leg padding may be authorized subject to FIA/ACO approval.

14.8 Wheel retention

A method of retaining the wheels providing an automatic safety retain of the nut must be installed. The manufacturer must demonstrate the robustness of the system.

14.9 Wheel tethers

14.9.1 In order to help prevent a wheel becoming separated in the event of all suspension members connecting it to the car failing provision must be made to accommodate flexible tethers. The sole purpose of the tethers is to prevent a wheel becoming separated from the car, they must perform no other function.

14.9.2 The tethers and their attachments must also be designed in order to help prevent a wheel making contact with the windscreen during an accident.

14.9.3 Each wheel must be fitted with two tethers.

The tethers must be homologated in accordance with FIA 8864-2013 standard (FIA Technical List 37).

The energy absorption of each cable shall not be less than 8kJ over the first 400mm of displacement.

14.9.4 Each tether must have its own separate attachments at both ends which:

- are able to withstand a tensile force of 80 kN in any direction within a cone of 45° (included angle) measured from the load line of the relevant suspension member.
- are separated by at least 100mm (measured between the centres of the two attachment points) on the survival cell or gearbox.
- are separated by at least 90° radially with respect to the axis of the wheel and at least 100mm (measured between the centres of the two attachment points) on each wheel/upright assembly.
- are able to accommodate tether end fitting loops with a minimum inside diameter according to the indication on the homologation label on the cable.

14.9.5 Furthermore, no suspension member may contain more than one tether.

14.9.6 Each tether must have a minimum length of 400 mm.

14.10 Seat

The driver's lateral and dorsal support must be achieved by the seat and the basic areas of support must be in compliance with dimensions on Drawing n°14-B. The top face of the shoulder support must be horizontal and at 530 mm from Zref plane. It is recommended that the shape of the dorsal support targets an angle of 55° tangent at L1 on spine.

The lateral and dorsal body supports must be approved by the FIA in accordance with the approval procedure of safety structures for sports cars. The minimum notice is 8 weeks from the foreseen test dates.

Any seat insert must be made from a material featuring in FIA Technical List n°50.

14.11 Frontal Head Restraints

No Frontal Head Restraint worn by the driver may be less than 25 mm from any structural part of the car when he is seated in his normal driving position.

14.12 Towing eyes

Front and rear towing eyes must:

- be designed such that the temperature of the towing eyes is less than 50° at anytime;
- be rigid, made from steel, with no chance of breaking, have an inner diameter between 80 mm and 100 mm and be 5 mm minimum thick (round section for not cutting or damaging the straps used by the marshals);
- be securely fitted to the chassis/structure by means of a metallic rigid piece (cable hoops are not permitted);
- be within the perimeter of the bodywork as viewed from above;
- be visible from outside, easily identified and painted in yellow, red or orange; they must have an arrow (of signal color and self-reflecting) on the bodywork which shows the point where to grab the eye.
- allow the towing of a car stuck in a gravel bed.

If towing eyes are integrated in the bodywork, there must be a tape/handle to bring them out for marshals with gloves on. This tape/handle must be of signal colour. Covering towing eyes is strictly forbidden.

14.13 Lifting devices

Two anchor points are mandatory on the top of the car in order to lift it with a crane.

These anchor points must be 2 lifting bushes integrated in the structure of the top of the car (see Appendix 6).

They must permit the car to be lifted safely on an altitude of 1.5 meters above ground. The car angle must be less than 25° with car complete with mid fuel tank.

The access to the bushes must be easy and location specifically marked as follows:

- with a circle of 5mm thick (of signal colour and self-reflecting) around the opening. In case the bushes are not visible from the side, arrows (of signal colour and self-reflecting) must be used on each side to make them visible from the side (one per side).
- The opening area must be covered to avoid risk of possible track debris to contravene insertion of lifting pin in case of need. The covering sticker needs to allow correct and complete insertion of lifting pin without effort or needs to be easily peelable by a marshal wearing gloves. Any kind of rigid cover is forbidden.

Their relative distance must comply with the distance on the lifting boom: 320 to 400 mm.

The maximum angle of bushes compared to vertical is 45°.

14.14 General electrical safety

Specifications are laid down in Appendix J – Article 253-18.1 (except for 18.1.f).

The maximum peak voltage on the car must never exceed 1000V.

14.15 Electronic Control Unit

The ECU must be designed to run from a car supply system provided by an auxiliary battery and through the auxiliary circuit, as defined by Article 8.3.2.

14.16 General Circuit Breaker

Specifications are laid down in Appendix J – Article 253 18 (18.17 except for 18.17.c)-d)-f).

See Drawing 10 for the general switching diagram.

All vehicles must be equipped with a general circuit breaker, of a sufficient capacity and which can be operated easily by a trigger button from the driver's seat when the driver is seated in a normal and upright position, with the safety belts fastened and the steering wheel in place, and from the outside, to cut off all electric transmission devices.

14.16.1 Neutral and general circuit breaker switches

The external neutral switch and the general circuit breaker switch (according to Article 14.16) must be coupled in a single switch so that a marshal can disengage the clutch and switch off all electric devices from the outside. They must:

- a) Be two identical switches, each of them located on each side of the car symmetrically to the car centre line, below a line under Z dashboard + 40 mm, in front of the A-Pillar and fixed to the survival cell,
 - b) be less than 350 mm from the door openings,
 - c) be less than 70 mm from the extinguisher switches defined in Article 14.2.2,
 - d) be of the type push button or lever,
 - e) with the device defined as above,
 - f) switch off all electrical circuits (auxiliary and power circuits) inside the car and to isolate the ES from the power circuit,
 - g) be designed such that a marshal is unable to accidentally re-energize the power circuit,
 - h) The switches must be marked with two self-reflecting stickers as follows:
 - a red spark in a white-edged blue triangle with a base of at least 120 mm. The angle of the triangle where the spark is pointing to, must point to the switch.
 - a letter "N" in red at least 40mm tall, with a line thickness of at least 4 mm, inside a white circle of at least 50mm diameter with a red edge with a line thickness of at least 2 mm.
- It must be self-reflecting. It is prohibited to cover this switch/button in any way whatsoever.



In a crash, all energy sources of the Power Circuit must be switched off automatically by electric switches or contactors and the full ES must be isolated. Those arrangements must be validated by the failure mode analysis submitted by the homologation. General specifications are laid down in Appendix J – Article 251-3.1.14.1.c and Article 253-18.18.

14.17 Cables, lines, electrical equipment

The specifications laid down in Appendix J – Article 253 (18.2.a is not applicable).

Brake lines, electrical cables and electrical equipment must be protected against any risk of damage (stones, corrosion, mechanical failure, etc.) when fitted outside the vehicle, and against any risk of fire and electrical shock when fitted inside the bodywork.

All electrical cables working with a voltage over 60 V must stay inside the X/Y plan above the survival cell reference plane.

14.18 Protection against electrical shock

Protection must be guaranteed according to Appendix J – Article 253-18.7, except Article 253 18.7.e.

14.19 Equipotential bonding

To mitigate the failure mode where a high voltage is AC coupled onto the car's low voltage system, it is mandatory that all major conductive parts of the body are equipotentiality bonded to the car chassis with wires or conductive parts of an appropriate dimension. See Appendix J – Article 253-18.8.

14.20 Isolation resistance requirements

All electrically live parts must be protected against accidental contact as laid down in Appendix J – Article 253-18.9.

14.21 Additional protection measures for the AC circuit

Additional protection measures are laid down in Appendix J – Article 253-18.9.1.

14.22 Isolation surveillance of chassis and power circuit

An isolation surveillance system must be used to monitor the status of the isolation barrier between the voltage class B system and the chassis.

Configurations are laid down in Appendix J – Article 253-18.10.

14.23 Power circuit

Power circuit specifications are laid down in Appendix J – Article 253-18.11.

14.24 Power bus

Specifications are laid down in Appendix J – Article 253- 18.12.

14.25 Power circuit wiring

The power circuit comprises the ES, the converter (chopper) for the drive motor(s), the contactor(s) of the general circuit breaker, fuses, the generator(s) and the drive motor(s).

All cable and wire specifications are laid down in Appendix J – Article 253-18.13.

14.26 Power circuit connectors, automatic disconnection

Power circuit connectors may not have live contacts on either the plug or the receptacle unless they are correctly mated. Specifications are laid down in Appendix J – Article 253-18.14.

Power circuit connectors environmental sealing must at least correspond to the standard:

- IP 55 in mated condition
- IP 2X in disconnected state

14.27 Insulation strength of cables

All electrically live parts must be protected against accidental contact according to Appendix J – Article 253-18.15.

14.28 Overcurrent trip (fuses)

Fuses and circuit breakers (but never the motor circuit breaker) count as overcurrent trips. Extra fast electronic circuit fuses and fast fuses are appropriate.

Overcurrent trips are specified in Appendix J – Article 253-18.19.

14.29 Safety Indicators

The specifications laid out in Appendix J – Article 253 18.22 are applicable.

All indicators must have a viewing angle of at least 120° and a luminous flux of at least 8 lumens.

The mandatory fitted safety light is detailed in FIA Technical List n°46.

a) ES safety light

All cars with an ES system must be fitted with the FIA/ACO ES safety lights. These must be:

- in working order throughout the event even if the main hydraulic or pneumatic on the car have failed;
- located as follows, with homologated positions:
 - On the dashboard, 1 Green indicator (made of 2 redundant lights) and 1 Red indicator (made of 2 redundant lights), specified and sourced by the team. The dashboard indicator(s) may present two brightness levels (night and day).
 - Close to the 2 Neutral and General Circuit Breaker Switches on both sides of the vehicle the mandatory FIA/ACO ES safety light. This is detailed in FIA Technical List n°46 and encompasses ES safety (red and green) and the medical light (blue), article 14.33.
- powered for at least 15 minutes after the general circuit breaker is activated.
- marked with a "HIGH VOLTAGE" symbol.

ERS Status Light	ERS Status
GREEN	SAFE
RED	DANGER (System Defect)

b) Ready-to-move light

In order to indicate that the car can move if the throttle pedal is activated, the front day lights and the rear position light of the car must be activated.

Whilst charging with the control system powered, the ready-to-move light must flash "on" for less than 0.05 seconds and "off" for 2 seconds.

It must flash "on" for 0.5 seconds and "off" for 0.5 seconds if, when the system has been requested to energise, the bus voltage has not exceeded 50 V.

Switch Position	Front day-light and Rear position-light		
	Threshold	On Duration	Off Duration
In P2			
Car stand Still		Always on	

Car on torque		Always on	
Switching P1 to P2	<50V	500ms	500ms
Switching P2 to P1		Off	
Charging		50ms	2000ms

14.30 Charging units

Charging units must satisfy the requirements laid down in Appendix J – Article 253-18.20 except for 18.20.a) (external or internal charging units TBC).

The competitor must supply the relevant technical and safety documents about the charging unit to the FIA/ACO 3 months prior to the first event.

14.31 Battery Management System

For lithium batteries, it is mandatory to have a control on the temperature, current and voltage and to isolate all loads in case of failure.

14.32 Accident data recorders (ADR) and high-speed accident cameras

Accident Data Recorders and High Speed Accident cameras are compulsory and must be fitted and operated in accordance with the instructions of the FIA.

14.33 Medical light

In order to give rescue crews an immediate indication of accident severity each car must be fitted with two warning lights connected to the FIA/ACO data logger. These must be part of the ES safety lights module and installed as described in article 8.8.

ARTICLE 15: SAFETY STRUCTURES

15.1 Rollover structures

15.1.1 General prescriptions

Two safety rollover structures (front and rear) are mandatory. They must be:

<ul style="list-style-type: none"> • At least 950 mm above survival cell reference plane at the front over a minimum width of 300 mm, and 935 mm above survival cell reference plane at the rear over a minimum width of 400 mm. • Separated by a minimum of 600 mm • Be symmetrical to the longitudinal vertical plane of the car. 	<p>Other than respecting all the constraints in these technical regulations, the survival cell of the car must follow the original survival cell car except modifications needed for racing or for achieving compliance with the present regulations.</p> <p>Modifications made to the original structure intending to fulfill the minimum safety requirements set for prototype cars maybe authorized subject to FIA/ACO approval.</p>
--	---

15.1.2 Rear rollover structure

<ul style="list-style-type: none"> • Whatever the shape of the survival cell, there must be a structural link from the top of rear rollover structure to the rearmost face of the survival cell. 	
<ul style="list-style-type: none"> • Must have a minimum overall length of 400 mm measured at the level of the mountings on the survival cell (i.e. at 500 mm minimum from the survival cell reference plane). • no part of the engine block, cylinder heads, cam covers and visible element of the engine fixations inserted in the survival cell is allowed at a distance less than 400 mm measured from the front vertical face of the rear rollover structure. • the rollover structure must not obscure sight of any part of the engine (engine block and head cylinders), viewed from directly above the car and from the side. 	
<ul style="list-style-type: none"> • The vertical front face of the rear rollover structure will be considered as a reference surface in X direction (Xref). It must extend over the entire cockpit on driver and passenger side and above Z500. 	<ul style="list-style-type: none"> • The vertical front face of the rear rollover structure will be considered as a reference surface in X direction (Xref).
<ul style="list-style-type: none"> • The rear face of the survival cell must have an area greater than 180 000 mm² at 400 mm minimum from Xref. 	

15.1.3 Rollover structures approval

Each rollover structure must be approved by the FIA in accordance with the approval procedure of safety structures for sports cars (Appendix to the Technical Regulations).

15.2 Survival cell

15.2.1 General prescriptions

<p>A 25 mm hole is mandatory on the top of the survival cell to allow the passage of cables between the cockpit and the mandatory official equipment installed on the top of the bodywork.</p>	
<p>The chassis structure must include a monobloc and continuous survival cell including the fuel tank, the ES, extending from the vertical plane at least 300 mm in front of the driver's feet (as described in Article 13.3) to at least 400 mm behind the Xref plane.</p> <p>The survival cell must provide lateral protection up to a minimum height of 500 mm from the survival cell</p>	<p>The chassis structure must include a survival cell including the fuel tank, the ES, extending from the vertical plane at least 300 mm in front of the driver's feet (as described in Article 13.3) to behind the Xref plane.</p> <p>Other than respecting all the constraints in these technical regulations, the survival cell of the car must follow the original survival cell car except local</p>

reference plane along the total length of the cockpit access.	modifications needed for racing or for achieving compliance with the present regulations. Modifications made to the original structure intending to fulfill the minimum safety requirements set for prototype cars maybe authorized subject to FIA/ACO approval.
All the protections defined in Article 15.2.2 and Article 15.2.3 must not be bonded to the survival cell for the approval of the safety structures.	

15.2.2 Supplementary panel – Leg template and driver and the passenger bodies template

One supplementary panel must be permanently attached to the survival cell with an appropriate adhesive (specifications in Appendix 5) which has been applied over its entire surface including all overlapping joints. It must be made of a maximum of three parts the construction of which must comply with the specifications in Appendix 5. If made up by more than one part, it must have all adjacent parts overlapping by a minimum of 25mm. These overlaps may include linear tapers in the thickness of both parts.	
It must, in side view: <ul style="list-style-type: none"> in X direction, cover symmetrically with respect to the car centerline the area lying between the front plane most forward point of the volume for driver’s legs (as defined in Article 13.6) up to Xref plane. A 25mm horizontal linear taper may be included at both ends. in Z direction, it must extend from the lower plane up to the upper plane of the volume for the driver’s and passenger’s leg (as defined in Article 13.6). It must extend from Z50 to Z450 between the rear of the leg’s Template and Xref plane. 	
Cut-outs in this panel totalling 25000 mm ² per side are permitted for fitting around wiring loom holes and essential fixings.	

15.2.3 Supplementary panel – Fuel tank/ES

One supplementary panel must be permanently attached to the survival cell with an appropriate adhesive (specifications in Appendix 5) which has been applied over its entire surface including all overlapping joints. It must be made up of a maximum of three parts the construction of which must comply with the specifications in Appendix 5. If made in more than one part, it must have all adjacent parts overlapping by a minimum of 25mm. These overlaps may include linear tapers in the thickness of both parts.	
It must, in side view: <ul style="list-style-type: none"> in X direction, cover the area lying between Xref plane and at least 400 mm behind Xref plane (to the rear face of the survival cell); in Z direction, cover the area lying between Z100 plane and Z450 plane. 	
A 25mm horizontal linear taper may be included at front end. Cut-outs in this panel totalling 20000 mm ² per side are permitted for fitting around wiring loom holes, ES ventilation holes and essential fixings. The supplementary panels described in Art.15.2.2 and Art.15.2.3 may be made from one part.	

15.2.4 Survival cell approval

The survival cell must be approved by the FIA in accordance with the approval procedure of safety structures for sports cars that can be found in the Appendixes to these Technical Regulations.
The minimum notice is 8 weeks from the foreseen test dates.

15.3 Front Impact Absorbing Structure - FIAS

15.3.1 General prescriptions

A FIAS must be fitted in front of the survival cell. This structure should not be an integral part of cell survival, but it must be securely attached with a minimum of 4 fixations.

The design of this structure is free but must meet the following points:

- Every outside structural cross section between two vertical and transversal planes positioned respectively 150 mm and 450mm behind its most forward point, must allow fitting a rectangular section of 24000 mm², with both horizontal and vertical dimensions being greater than 80 mm.
- Forward a vertical and transversal plane positioned 450 mm behind its most forward point, the complete impact absorbing structure has to be between 150 mm and 500 mm above the reference surface.

15.3.2 Approval

The FIAS must be approved by the FIA in accordance with the approval procedure of safety structures for sports cars.

The minimum notice is 8 weeks from the foreseen test dates.

The crash test weight must be equal to [1100 Kg (car) + 80 Kg (driver) + maximum fuel tank volume x 0.75 (fuel) + 50 Kg (ballast)]

15.4 Rear Impact Absorbing Structure - RIAS

15.4.1 General prescriptions

A RIAS must be fitted behind the gearbox symmetrically about the car centre line and no more than 200 mm forward the rearmost point of the bodywork.

The perimeter of the most rearward vertical and transversal face of the rear absorbing structure must form a continuous and closed section with a minimum height of 100 mm maintained over a minimum width of 130 mm.

The centre of this 100mm tall and 130mm wide rectangular section must be between Z250 plane and Z300 plane.

The extrusion in pure longitudinal direction toward the front, over a length of 300 mm, of the perimeter of the most rearward face, should not protrude from the most outboard faces of the rear absorbing structure.

This structure is considered as a bodywork element.

It must be constructed from materials which will not be substantially affected by the temperatures it is likely to be subjected to during use.

The sole additional components allowed to be fitted on this structure are the rear wing pillars, the jacks, the towing eye, the engine cover and the floor and/or rear diffuser.

15.4.2 Approval

The RIAS must be approved by the FIA in accordance with the approval procedure of safety structures for sports cars.

The minimum notice is 8 weeks from the foreseen test dates.

15.5 Modifications

Any modification of a safety structure approved by the FIA must be submitted by the car Manufacturer to the FIA Technical Department.

The latter reserves the right to require that new tests be carried out to proceed with the approval of the modification.

ARTICLE 16: MATERIALS

16.1 Magnesium

Magnesium is permitted apart from sheets less than 3mm.

16.2 Metallic materials

No parts of the car may be made from metallic materials which have a specific modulus of elasticity greater than 40GPa / (g/cm³). Tests to establish conformity will be carried out in accordance with FIA Test Procedure 03/03 (Appendix to the Technical Regulations).

ARTICLE 17: FUEL

17.1 Supplying

The Organiser will supply only one type of fuel which must be used by all cars without making any modification to its chemical composition.

17.2 Specifications

17.2.1 Petrol

≥ 15% bio basis.

17.2.2 Other fuel

The use of any other fuel is subject to a special request submitted to the agreement of the Endurance Committee.

ARTICLE 18: TELEVISION CAMERAS AND TIMING TRANSPONDERS

18.1 Presence of cameras and camera housings

All cars must be fitted with cameras or camera housings at all times throughout the Event.

A camera in conformity with Technical list 46 pointing rearwards is mandatory. Its signal will be connected to the official TV.

18.2 Transponders

All cars must be fitted with two timing transponders supplied by the officially appointed timekeepers. These transponders must be fitted in strict accordance with the instructions detailed in the Appendix to the Technical Regulations. Competitors must use their best endeavours to ensure that the transponders are in working order at all times.

Front transponder (main) must be 1580 +/-50 mm from the front of the car.

Rear transponder (backup) must be at 3550 +/-100 mm the front of the car.

ARTICLE 19: HOMOLOGATION

19.1 Principles

A car Manufacturer may homologate a maximum of two cars during the five championship seasons (from January 2021 until December 2025) and both homologations will be valid until December 2025.

	In order to become eligible for Le Mans Hypercar homologation a minimum of 20 original cars must be manufactured and road homologated (ECE, DoT or equivalent) over 2 years starting from the 1 st race in which it will compete.
--	--

A complete homologation will be made of three parts:

- a) Car
- b) Engine
- c) ERS

19.1.1 Modifications to the original homologation may be done for the following reasons:

- a) Safety, reliability, serviceability, end-of-commercialisation or cost saving
- b) Performance

19.1.2 Modifications requested for safety, reliability, serviceability, end-of-commercialisation or cost saving reasons: They are not limited in number, but must respect the following procedure:

- Requested according to the calendar set in Article 19.5.2.
- According to the applicable homologation procedure.
- Applications must provide all necessary supporting information including, where appropriate, clear evidence of race failures.
- If the FIA/ACO is satisfied, in its absolute discretion, that these changes are acceptable and in line with the BoP process, they will confirm to the manufacturer concerned that they may be carried out.

19.1.3 Modifications requested for performance reasons:

Must respect the following conditions:

- No more than 5 Evolution extensions (EVO jokers) per manufacturer allowed from January 2021 until December 2025, regardless of the number of different homologations.
- An EVO joker equals whatever modification within the perimeter of each chapter of the relevant homologation form.
- Requested according to the calendar set in Article 19.6.2.
- According to the applicable homologation procedure.
- Applications must provide all necessary supporting information including the targeted performance improvement, its evolution and, if relevant, an updated datasheet.
- If the FIA/ACO is satisfied, in its absolute discretion, that these changes are acceptable and in line with the BoP process, they will confirm to the manufacturer concerned that they may be carried out.

19.2 Car Homologation

19.2.1 Any manufacturer intending to homologate a car for use by a competitor in the WEC during the 2021-2025 period must submit to the FIA/ACO a chassis homologation dossier according to the calendar set in Article 19.5.1.

19.2.2 The homologation dossier must include:

CAD drawings and other documents as required by the Appendixes to these Regulations.

The homologation form whose template can be found in the Appendixes to these regulations.

19.2.3 A car will be homologated for the relevant competitor once a complete homologation dossier has been submitted by the relevant manufacturer and has been approved by the FIA/ACO.

19.2.4 The homologation will be valid for five championship seasons (from January 2021 until December 2025).

19.2.5 A manufacturer may apply to the FIA/ACO during the course of the homologation period to carry out modifications to its homologated chassis according to article 19.1.

19.2.6 Any new car manufacturer, intending to homologate a car during the 2021-2025 period must provide the FIA/ACO with preliminary details of the car according to the calendar set in article 19.5.1 in addition to the homologation dossier as per Article 19.2.1 and Article 19.2.2. In order to homologate the submitted car, the FIA/ACO must also be satisfied, at its absolute discretion, that such a car could fairly and equitably be allowed to compete with other homologated car.

19.2.7 Both the manufacturer and users of a homologated car must take whatever steps are required at any time by the FIA/ACO, in its absolute discretion, to demonstrate that a car used at an Event is in conformity with the corresponding car homologation dossier.

19.3 Engine Homologation

19.3.1 Any manufacturer intending to homologate an engine for use by a competitor in the WEC during the 2021-2025 period must submit to the FIA/ACO an engine homologation dossier according to the calendar set in article 19.5.1.

19.3.2 The homologation dossier must include:

<ul style="list-style-type: none"> • Bespoke engine: Details of all the parts described as “INC” in the “Engine Homol.” column of the relevant table of Appendix 2 of these Regulations. • Engine based on an “engine of the make” Engine of the make details of all the parts described as “INC” in the “Engine Homol.” column of the relevant table of Appendix 2 of these Regulations. <p>Details of the differences between the homologated engine and the base engine.</p>	<p>Base engine details of all the parts described as “INC” in the “Engine Homol.” column of the relevant table of Appendix 2 of these Regulations.</p> <p>Details of the differences between the homologated engine and the base engine.</p>
---	--

Content of the details to be agreed on a case by case basis with FIA/ACO. It can be either CAD files, 2D drawings and/or parts deposits.

The homologation form templates can be found in the Appendixes to these regulations.

19.3.3 An engine will be homologated for the relevant competitor once a complete homologation dossier has been submitted by the relevant manufacturer and has been approved by the FIA/ACO.

19.3.4 The homologation will be valid for five championship seasons (from January 2021 until December 2025).

19.3.5 Each manufacturer shall submit a homologation dossier for each competitor it intends to supply. There may only be one homologation dossier per competitor.

19.3.6 A manufacturer may apply to the FIA/ACO during the course of the homologation period to carry out modifications to its homologated engine according to article 19.1.

19.3.7 Any new engine manufacturer, intending to homologate an engine during the 2021-2025 period must provide the FIA/ACO with preliminary details of the engine according to the calendar set in Article 19.5.1 in addition to the homologation dossier as per Articles 19.3.1 and 19.3.2. In order to homologate the submitted power unit, the FIA/ACO must also be satisfied, at its absolute discretion, that such a power unit could fairly and equitably be allowed to compete with other homologated power units.

19.3.8 Both the manufacturer and users of a homologated engine must take whatever steps are required at any time by the FIA/ACO, in its absolute discretion, to demonstrate that an engine used at an Event is in conformity with the corresponding engine homologation dossier.

19.4 ERS Homologation

19.4.1 Any manufacturer intending to homologate an ERS for use by a competitor in the WEC during the 2021-2025 period must submit to the FIA/ACO an ERS homologation dossier according to the calendar set in Article 19.5.1.

19.4.2 The homologation dossier must include:

Declaration from at least one competitor of its intention to use this ERS

Details of all the parts described as “INC” in the “ERS Definition” column of the relevant table of Appendix 2 of these Regulations.

The homologation form whose template can be found in the Appendixes to these regulations.

19.4.3 An ERS will be homologated for the relevant competitor once a complete homologation dossier has been submitted by the relevant manufacturer and has been approved by the FIA/ACO.

19.4.4 The homologation will be valid for five championship seasons (from January 2021 until December 2025).

19.4.5 Each manufacturer shall submit an homologation dossier for each competitor it intends to supply. There may only be one homologation dossier per competitor.

19.4.6 A manufacturer may apply to the FIA/ACO during the course of the homologation period to carry out modifications to its homologated ERS according to article 19.1.

19.4.7 Any new ERS manufacturer, intending to homologate an ERS during the 2021-2025 period must provide the FIA/ACO with preliminary details of the ERS according to the calendar set in Article 19.5.1. in addition to the homologation dossier as per Articles 19.4.1 and 19.4.2. In order to homologate the submitted power unit, the FIA must also be satisfied, at its absolute discretion, that such a power unit could fairly and equitably be allowed to compete with other homologated power units.

19.4.8 Both the manufacturer and users of a homologated ERS must take whatever steps are required at any time by the FIA/ACO, in its absolute discretion, to demonstrate that an ERS used at an Event is in conformity with the corresponding ERS homologation dossier.

19.5 Homologation calendar

19.5.1 Base homologations

	12 month	11 month	10 month	9 month	8 month	7 month	6 month	5 month	4 month	3 month	2 month	1 month	REF
CAR HOMOLOGATION													
H1 form	✓												
General presentation	✓												
CAD – Survival cell – Final													
Validation FIA / ACO Survival cell		✓											
Safety test Survival cell			✓										
CAD – Bodywork – Draft													
Validation FIA / ACO Bodywork			✓										
Manufacturing of bodywork				✓									
Wind tunnel test													
Homologation documents – Draft						✓							
CAD – Bodywork – Final								✓					
Inspection								✓					
Homologation documents – Final									✓				

	12 month	11 month	10 month	9 month	8 month	7 month	6 month	5 month	4 month	3 month	2 month	1 month	REF
ENGINE HOMOLOGATION													
General presentation	✓												
Datasheet – Draft						✓							
Homologation documents – Draft						✓							
Engine test							✓	✓					
Inspection								✓					
CAD – Engine – Final								✓					
Datasheet – Final								✓					
Part deposit								✓					
Homologation documents – Final									✓				

	12 month	11 month	10 month	9 month	8 month	7 month	6 month	5 month	4 month	3 month	2 month	1 month	REF
ERS HOMOLOGATION													
General presentation	✓												
Homologation documents – Draft						✓							
Inspection								✓					
Homologation documents – Final									✓				

19.5.2 Homologation extensions

	6 month	5 month	4 month	3 month	2 month	1 month	15 day	REF
SAFETY, RELIABILITY, SERVICEABILITY, END-OF-COMMERCIALISATION, COST SAVING (Article 19.1.2)								
General presentation						✓		
Homologation documents - Draft						✓		
Homologation documents – Final							✓	

	6 month	5 month	4 month	3 month	2 month	1 month	15 day	REF
PERFORMANCE BODYWORK (Article 19.1.3)								
General presentation	✓							
CAD – Bodywork – Draft		✓						
Validation FIA / ACO Bodywork			✓					
Manufacturing of bodywork				✓				
Wind tunnel test					✓			
CAD – Bodywork – Final						✓		
Homologation documents – Final						✓		

	6 month	5 month	4 month	3 month	2 month	1 month	15 day	REF
PERFORMANCE ENGINE (Article 19.1.3)								
General presentation		✓						
Datasheet – Draft			✓					
Homologation documents – Draft			✓					
Engine test				✓	✓			
Inspection					✓			
CAD – Engine – Final					✓			
Datasheet – Final					✓			
Part deposit					✓			
Homologation documents – Final						✓		

	6 month	5 month	4 month	3 month	2 month	1 month	15 day	REF
PERFORMANCE ERS (Article 19.1.3)								
General presentation			✓					
Homologation documents – Draft				✓				
Inspection					✓			
Homologation documents – Final						✓		

ARTICLE 20: FINAL TEXT

The final text for these regulations shall be the French version should any dispute arise over their interpretation.

APPENDIX 1

DRAWINGS

3C	Skid block
10	General Switching Diagram
13A	Template H1: Legs protection
13B	Template H2: Volume legs
13C	Template H3: Volume driver and passenger body
13D	Template H4: Volume driver and passenger head
13F	Template H6: Volume cockpit access
13G	Template V1: Driver's field of frontal visibility
13H	Template V2: Driver's field of lateral visibility
13I	Assembled Templates H
13J	Assembled Templates V
14A	Drawing of headrest
14B	Drawing seen from side of seat

REFERENCE CAD FILE NAME FOR ALL FIA/ACO
TEMPLATES

The CAD file supersedes the drawings here after in
the regulations



TR2021_TEMPLATES_FIA_ACO_yyyy_mm_dd.igs

Please ask FIA/ACO for latest CAD file release.

DRAWING 3C



SKID BLOCK

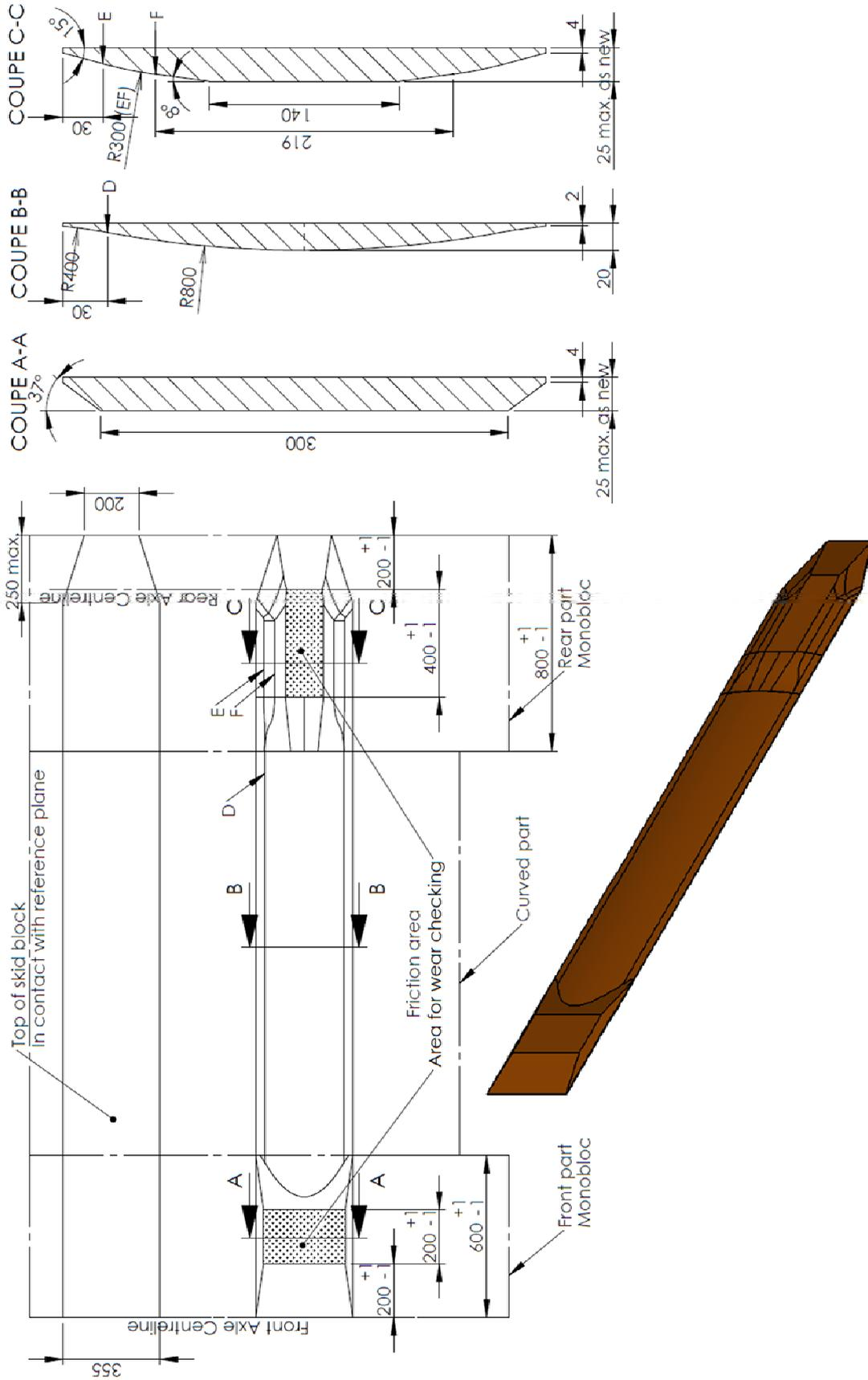

DRAWING 10



GENERAL SWITCHING DIAGRAM

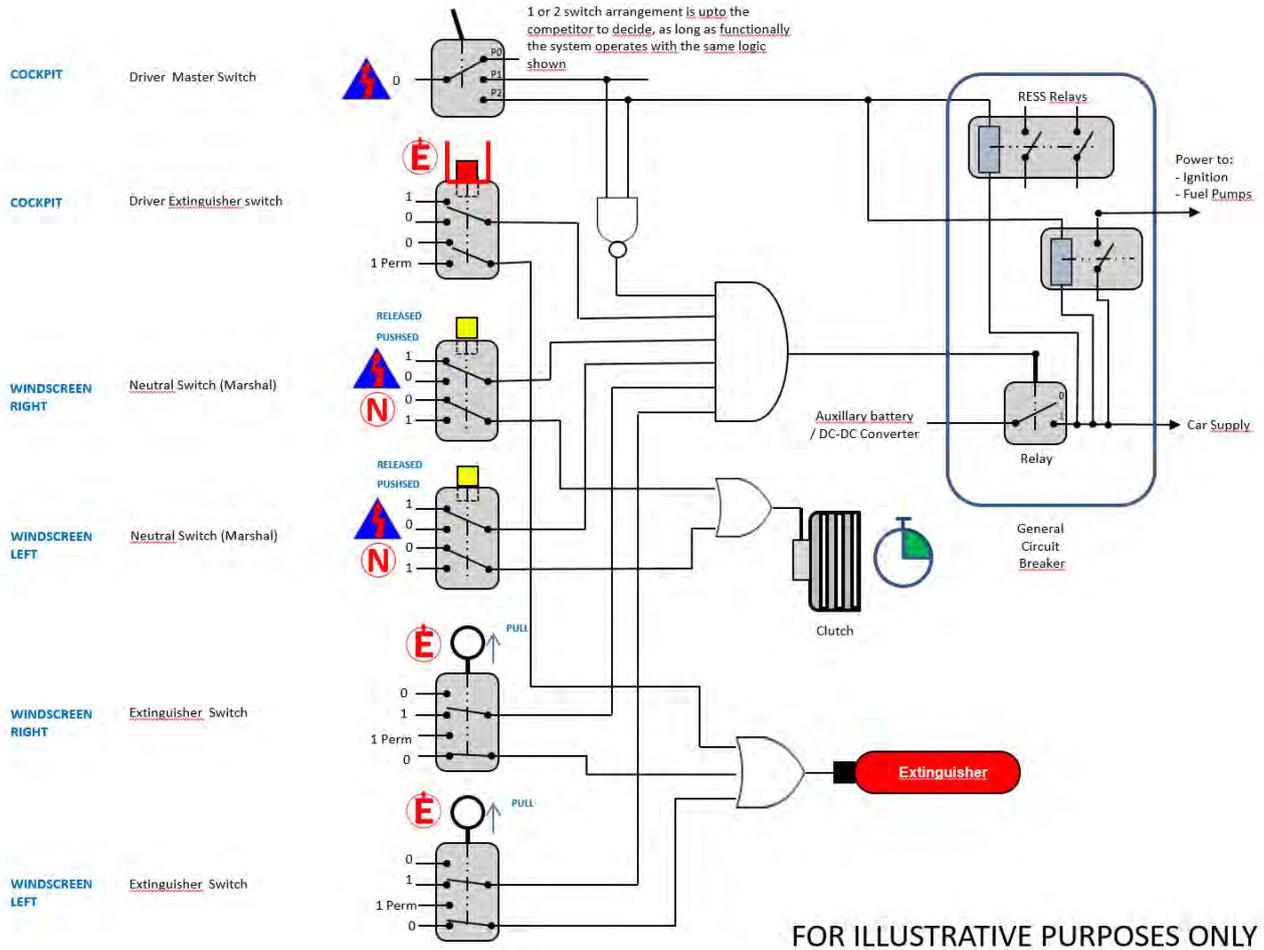

DRAWING 13A



TEMPLATE H1

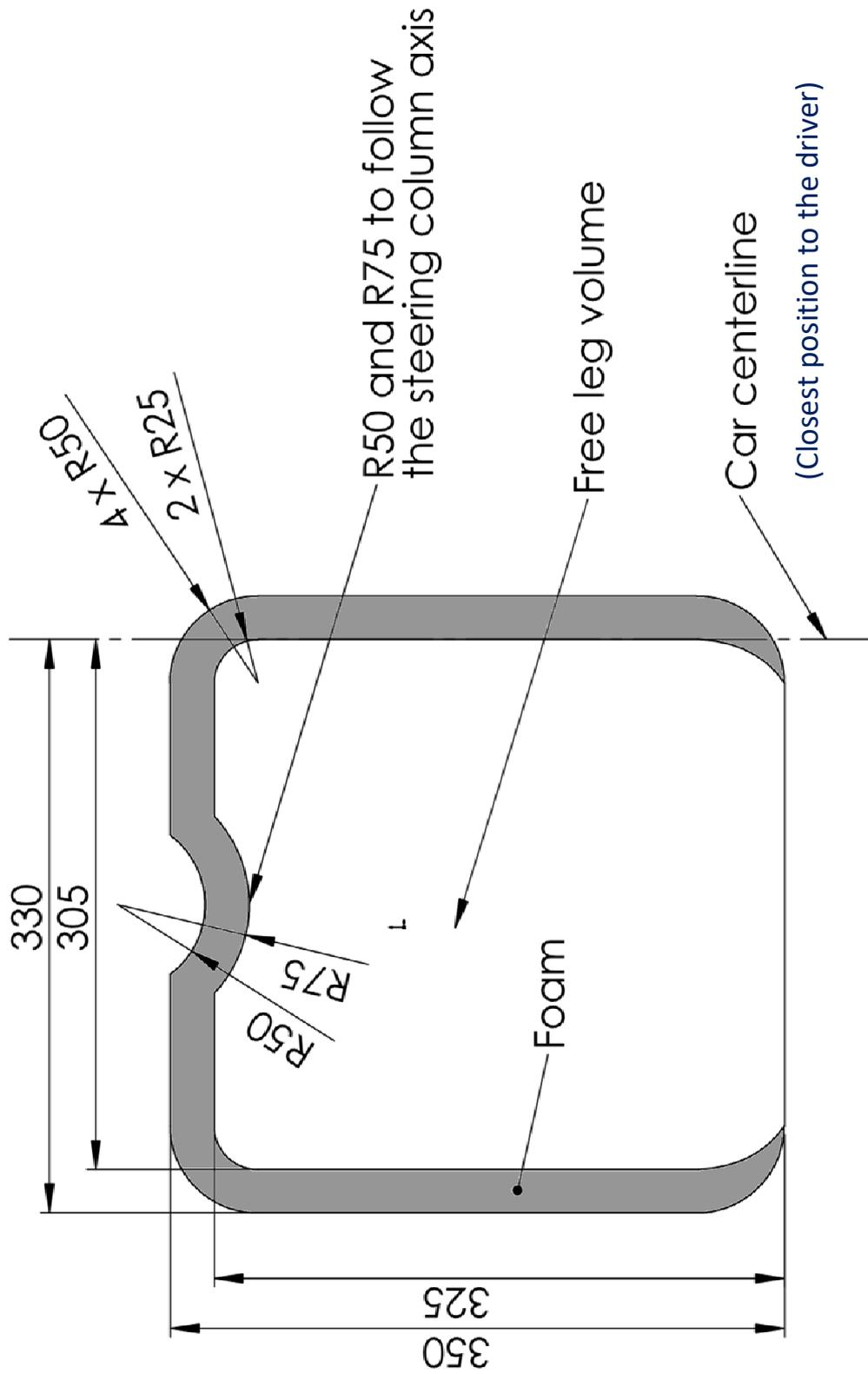

DRAWING 13B



TEMPLATE H2

DRAWING 13C



TEMPLATE H3

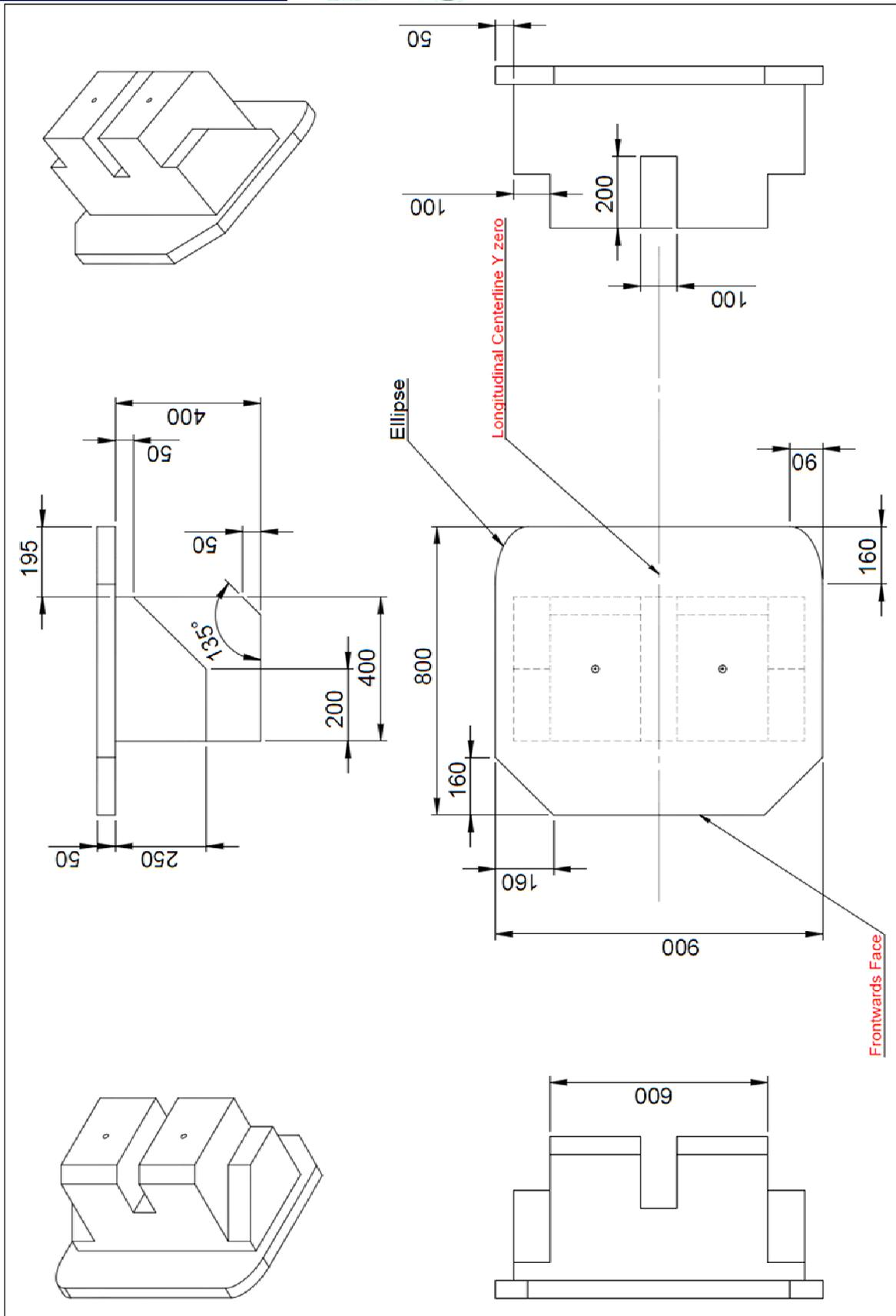

DRAWING 13D



TEMPLATE H4

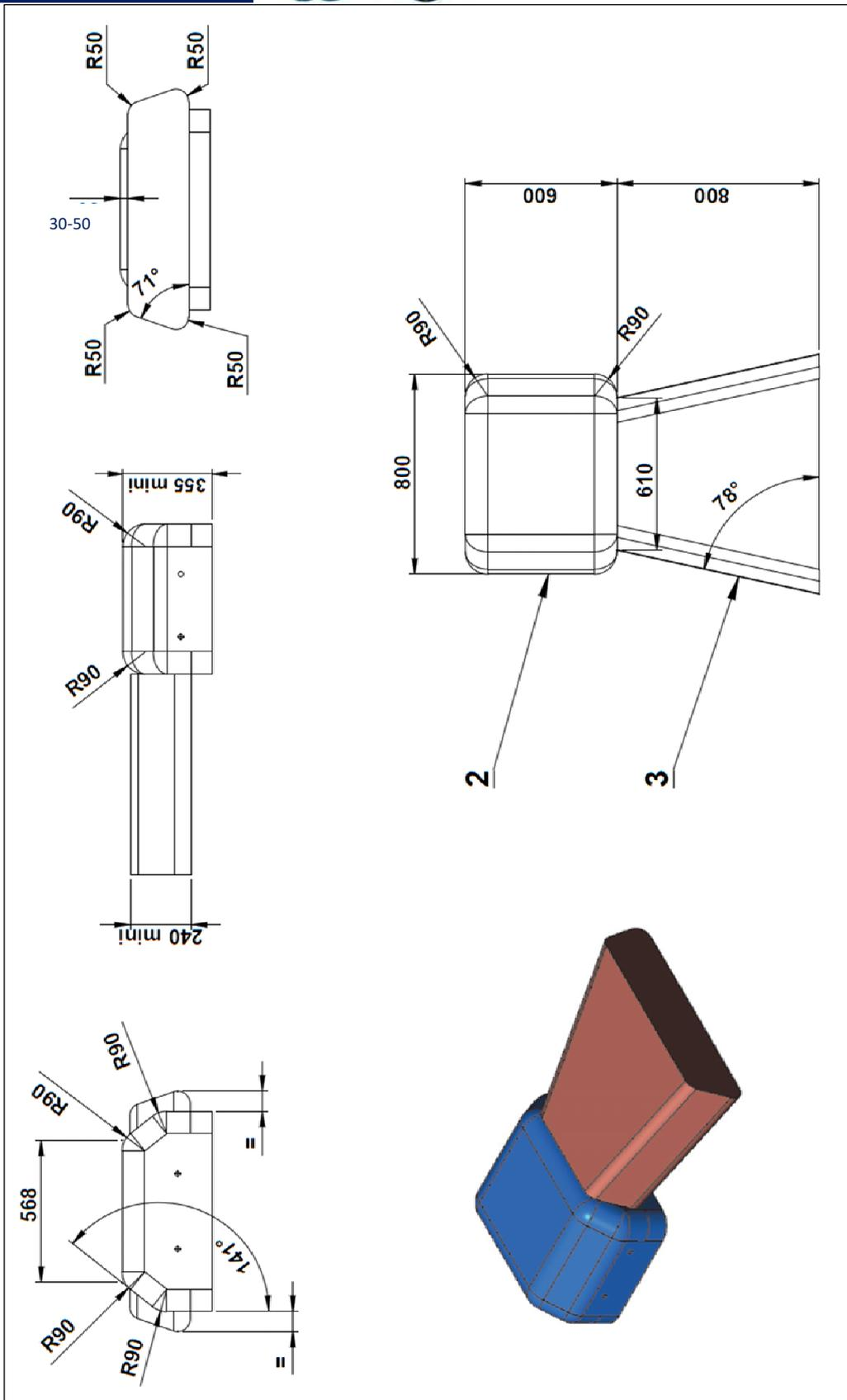

DRAWING 13F



TEMPLATE H6

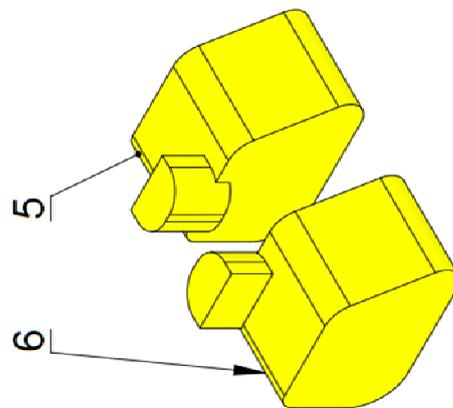
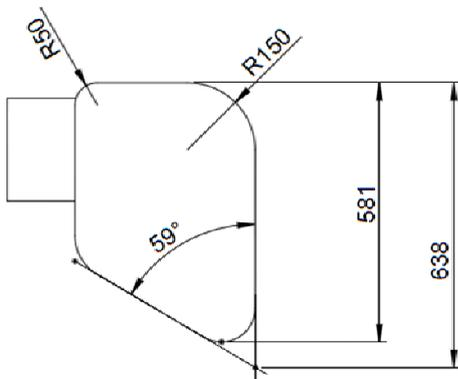
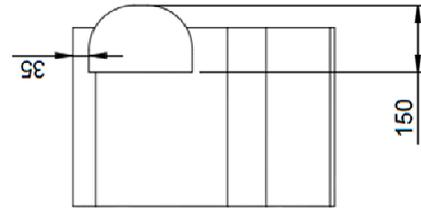
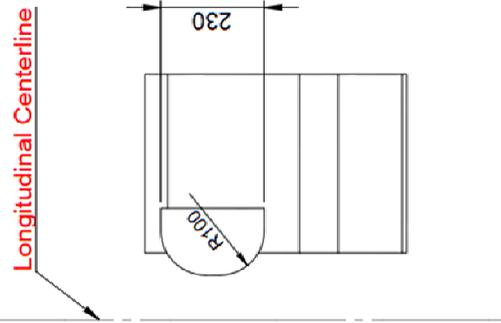
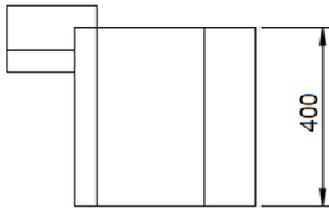
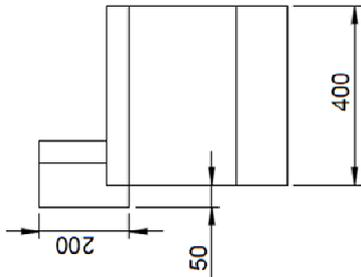
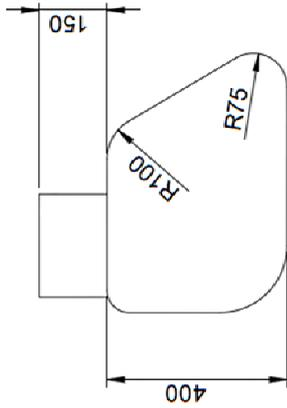

DRAWING 13G



TEMPLATE V1

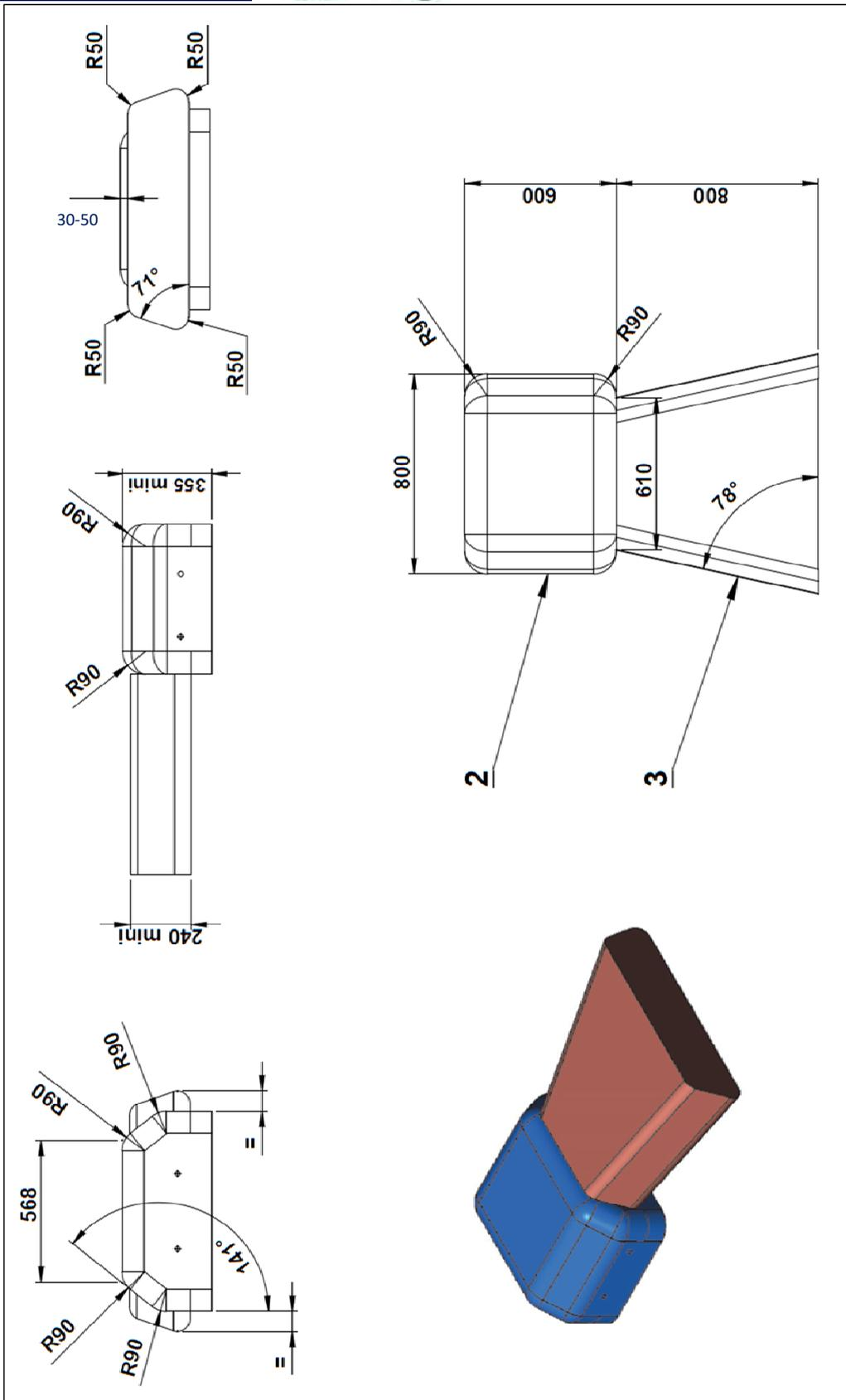

DRAWING 13H



TEMPLATE V2

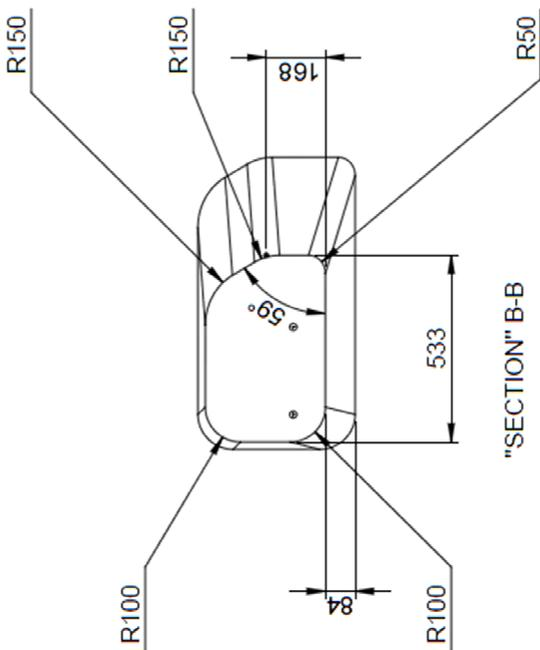
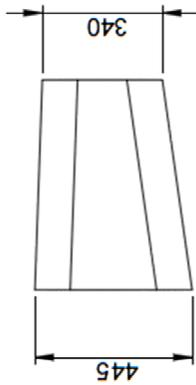
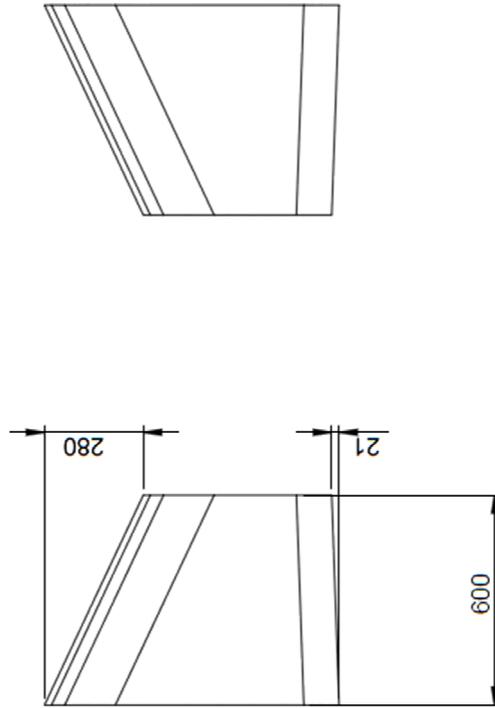
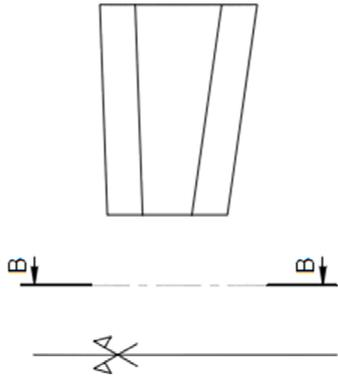

"SECTION" B-B

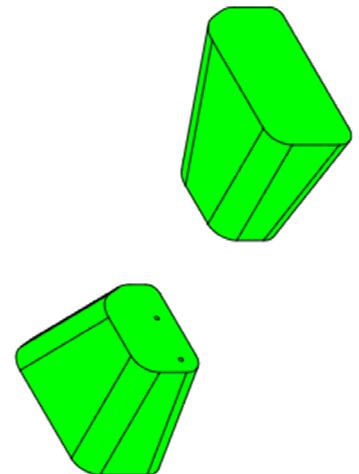
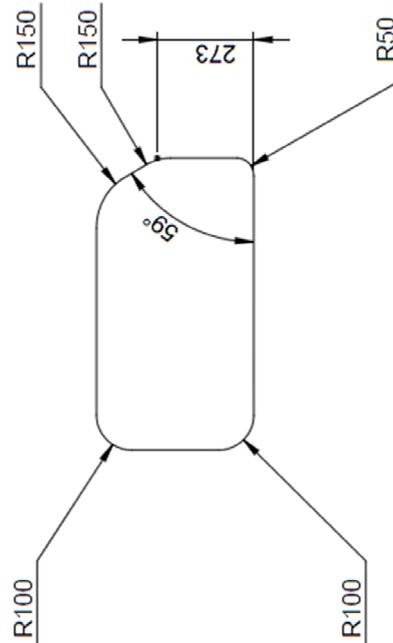

DRAWING 13I



DRIVER'S TEMPLATES H ASSEMBLY

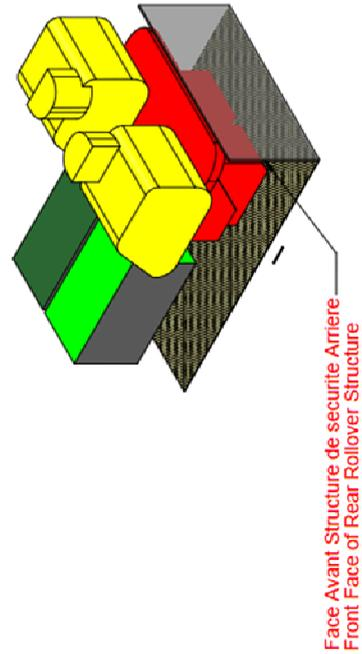
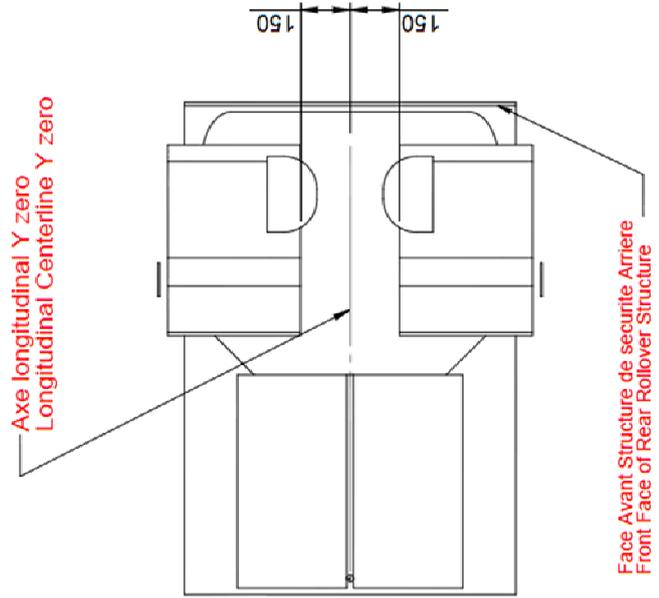
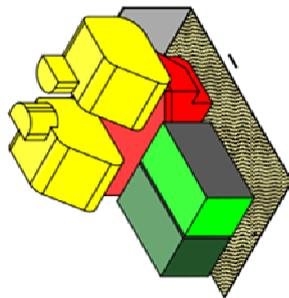
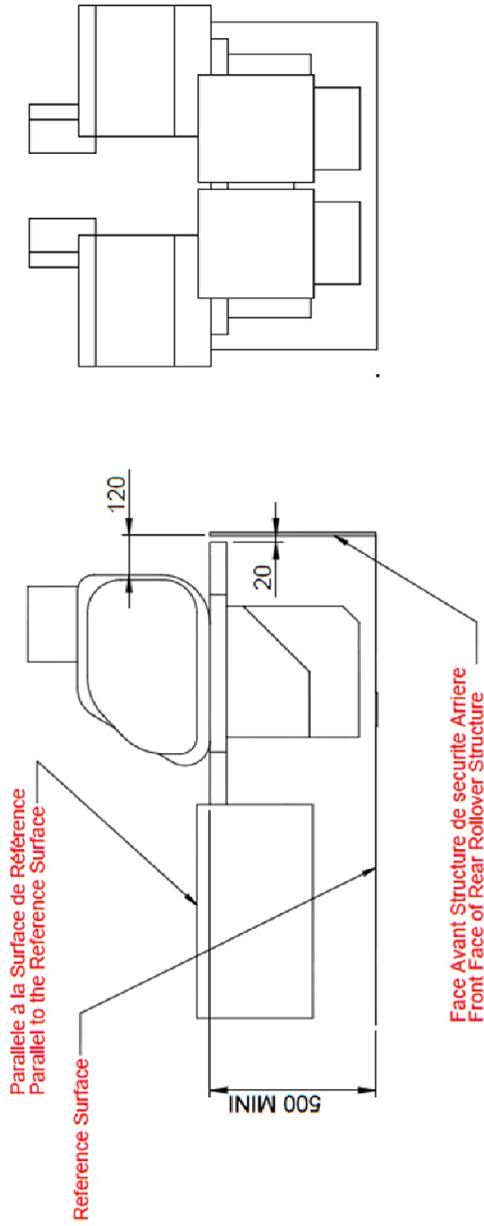

DRAWING 13J



TEMPLATES V ASSEMBLY

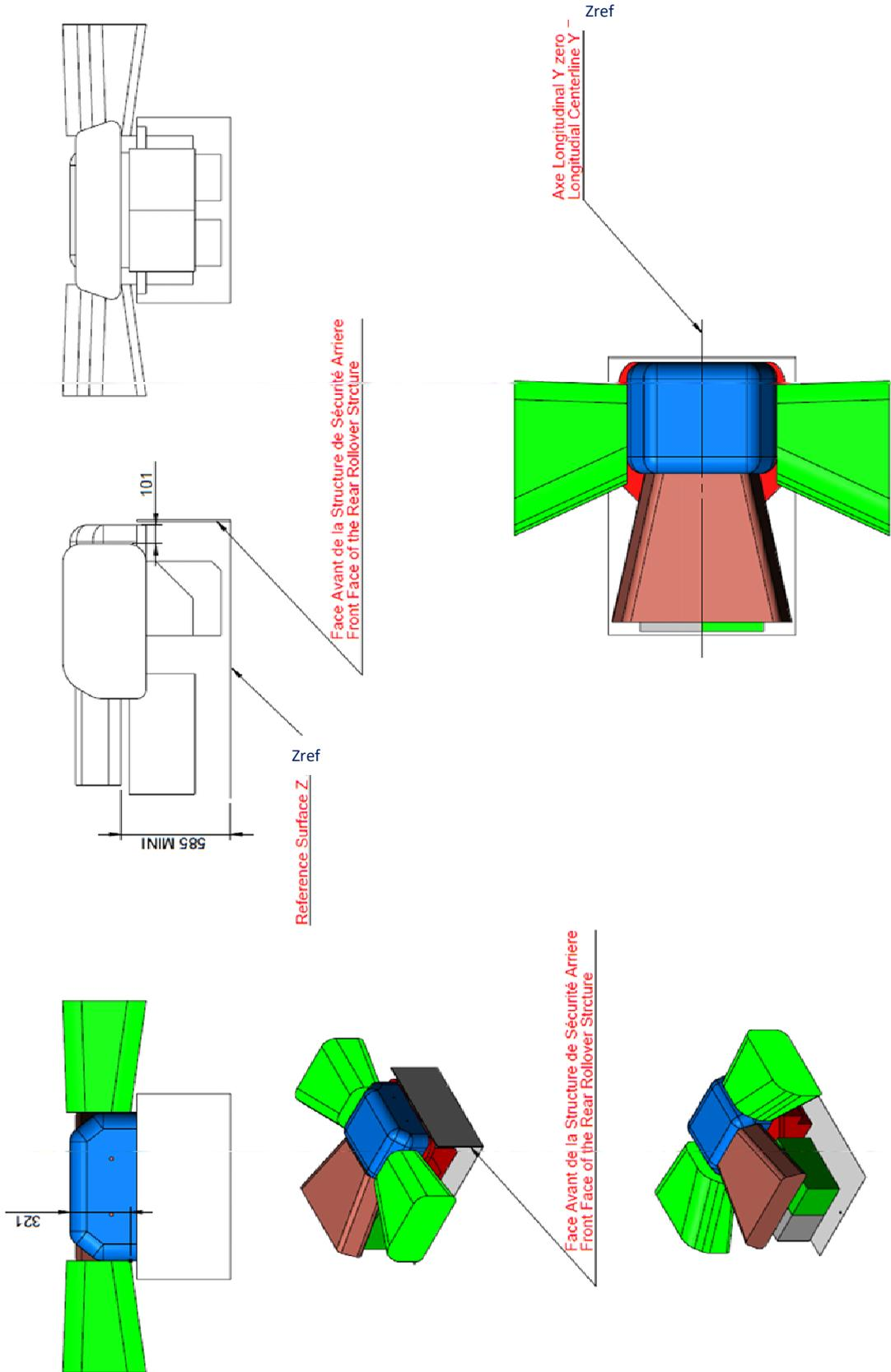

DRAWING 14A



HEADREST

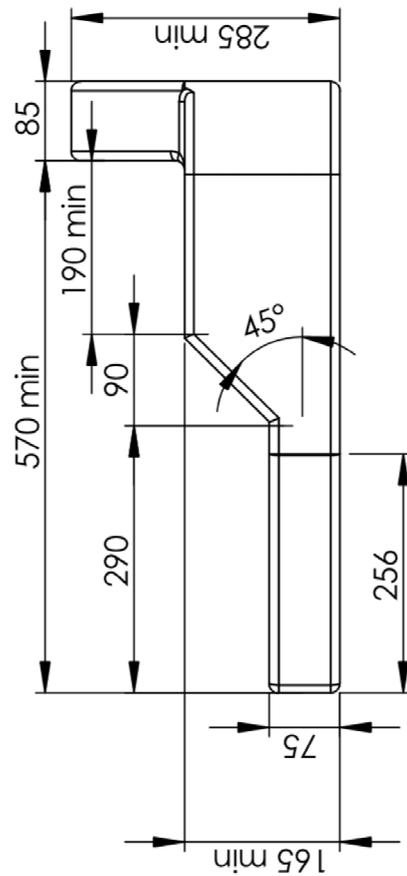
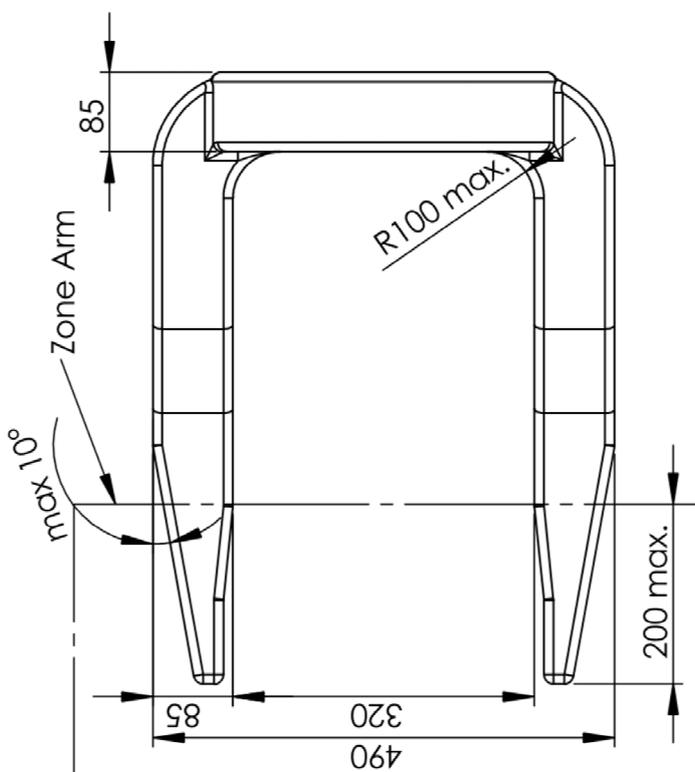
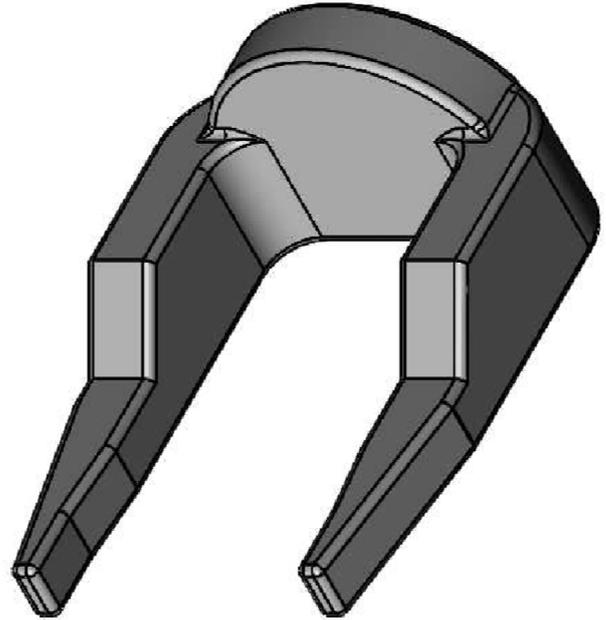
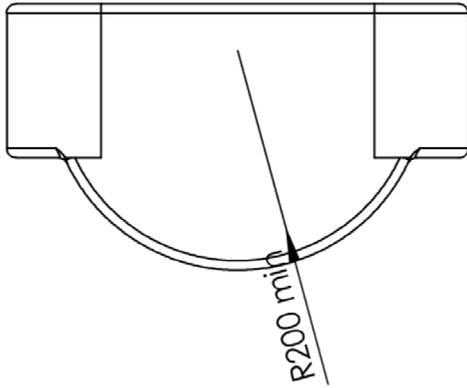

DRAWING 14B



SEAT

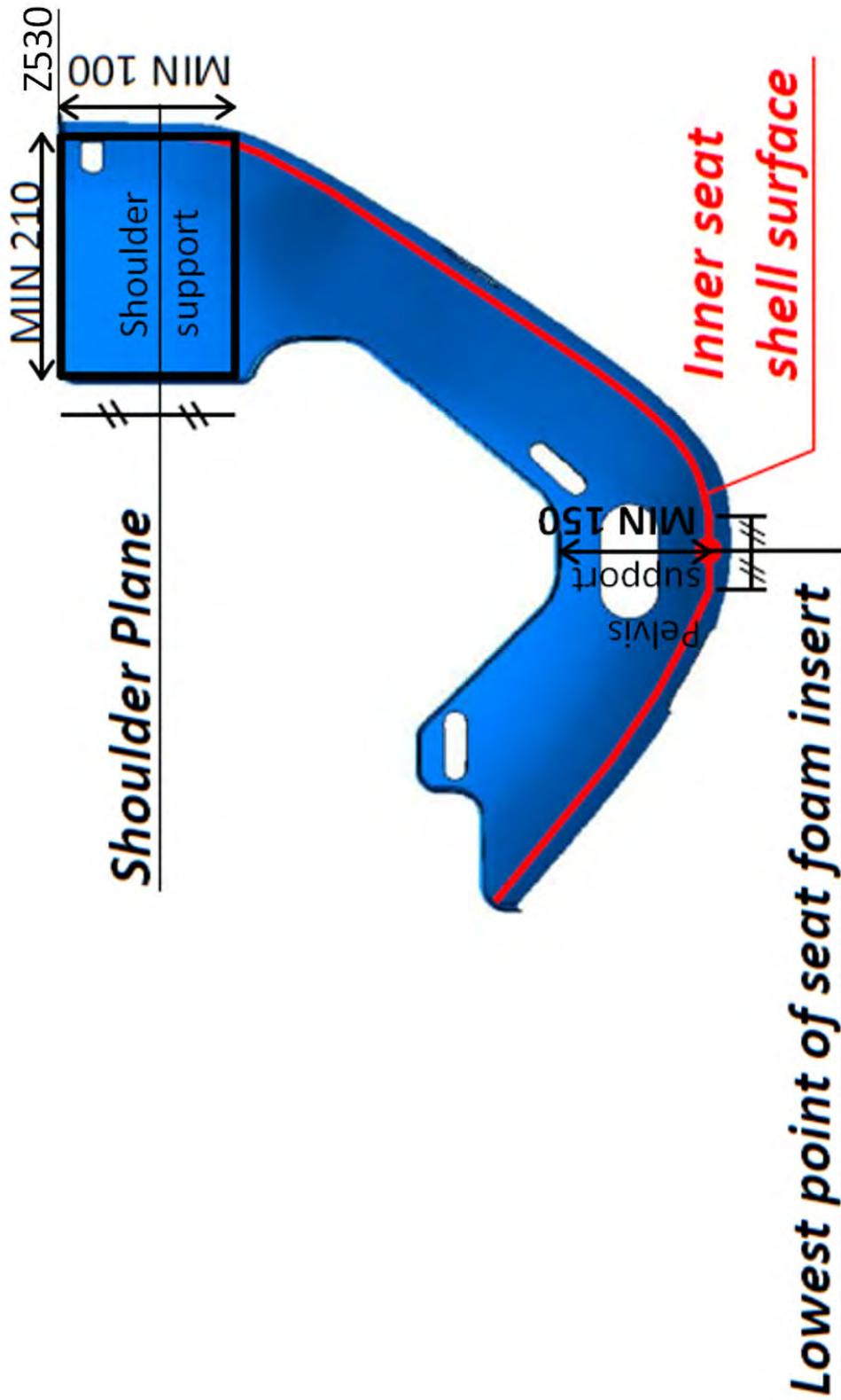

APPENDIX 2

POWER UNIT SYSTEMS, FUNCTIONS AND COMPONENTS

ENGINE

Item No	List of Engine functions / systems / components	ENGINE Definitions	Engine Homol	NA ENGINE Weight	NA ENGINE CoG	SC ENGINE Weight	SC ENGINE CoG
1	All Engine components within cam-covers, cylinder heads, crankcase, sump and any gear case	INC	INC	INC	INC	INC	INC
2	Engine pressure charging components (e.g. compressor from inlet to outlet including wheel; turbine from inlet to outlet including wheel; shaft, bearings and housings). Includes Wastegate, Pop-off valve or similar	INC	INC	EXC	EXC	INC	INC
3	Engine Engine air inlet system from Air filter to cylinder head (e.g. Pipes, Intercooler, plenum, trumpets, throttles) but excluding pressure charging components.	INC	INC	INC	INC	INC	INC
4	Engine exhaust system from the engine exhaust flange up to the exit	INC	INC	INC	INC	INC	INC
5	Engine mounted fuel system components: (e.g. High Pressure fuel hose, fuel rail, fuel injectors, accumulators)	INC	INC	INC	INC	INC	INC
6	Engine mounted electrical components (e.g. wiring loom, sensors, actuators, ignition coils, alternator, spark plugs)	INC	INC (Exc looms)	INC	INC	INC	INC
7	All Engine coolant pumps, oil pumps, scavenge pumps, oil air separators and fuel high pressure pumps (delivering more than 10bars) including any of the following associated components: motors, actuators, filters, brackets, supports, screws, nuts, dowels, washers, cables, oil or air seals. All tubes or hoses between components of the Engine. Excludes hydraulic pump.	INC	INC (Only pumps)	INC	INC	INC	INC
8	Engine main oil tank, catch tanks, and any breather system connected to them and associated filters, brackets, support, screws, nuts, dowels, washers, cables, tubes, hoses, oil or air seals	INC	EXC	EXC	EXC	EXC	EXC
9	Any ECU or associated device containing programmable semiconductors or containing high power switching device and associated brackets, support, screws, nuts, dowels, washers or cables used for Engine	EXC	EXC	EXC	EXC	EXC	EXC
10	Any actuators needed to make the Engine function at all times	INC	EXC	INC	INC	INC	INC
11	Water system accumulators used for Engine	INC	EXC	INC	EXC	INC	EXC
12	Heat exchangers (except intercooler) and their associated accessories (included but not limited to tubes, hoses, supports, brackets and fasteners) used for Engine	INC	EXC	INC	EXC	INC	EXC
13	Hydraulic system (e.g. pumps, accumulators) used for Engine	EXC	EXC	EXC	EXC	EXC	EXC
14	Hydraulic system servo valve(s) and actuator(s) for Engine control used for Engine	INC	EXC	INC	INC	INC	INC
15	Fuel feed pumps delivering less than 10 bars and their associated accessories (included but not limited to tubes, hoses, supports, brackets and fasteners).	EXC	EXC	EXC	EXC	EXC	EXC
16	Any ancillary equipment associated with the Engine air valve system such as regulators or compressors.	INC	EXC	INC	EXC	INC	EXC
17	Studs used to mount Engine to chassis or gearbox mounted on engine	INC	EXC	INC	INC	INC	INC
18	Flywheel, clutch and clutch actuation system between the Engine and the gearbox.	INC	EXC	INC	INC	INC	INC
19	Engine oil	INC	EXC	EXC	EXC	EXC	EXC
20	Liquids used for Engine. Excludes engine oil.	EXC	EXC	EXC	EXC	EXC	EXC
21	Ballast mounted on the Engine up to 5 kg.	INC	EXC	INC	INC	INC	INC
22	Ballast mounted on the Engine above 5 kg	EXC	EXC	EXC	EXC	EXC	EXC
23	Wiring harnesses which are not ordinarily part of a power unit.	EXC	EXC	EXC	EXC	EXC	EXC
24	Starter motor	EXC	EXC	EXC	EXC	EXC	EXC

INC: INCLUDED: These parts must be included in the definition/weight/box/template/perimeter or dossier.

EXC: EXCLUDED: These parts must be excluded from the definition/weight/box/template/perimeter or dossier.

ERS

Item No	List of functions / systems / components	ERS Definition	MGU-K Definition	ESC Definition
1	The ES cells (including any clamping plates) and electrical connections between cells	INC	EXC	INC
2	HV fuses	INC	EXC	INC
3	Ground fault Indication system	INC	EXC	INC
4	Main Contactors (electromechanical) including precharge switches, FIA IVTs	INC	EXC	INC
5	Safety pin (service plug)	INC	EXC	INC
6	DC HV busbars and wires between ES and CUK	INC	EXC	INC
7	DC HV EMC screening	INC	EXC	INC
8	DCDC Converter connected to HV DC bus	INC	EXC	INC
9	BMS, Voltage & temperature monitoring of cells	INC	EXC	INC
10	ERS controller, gate drive for K, phase current sensors	INC	INC	EXC
11	MGU-K 3 phase Inverter including large capacitor	INC	INC	EXC
12	3 phases connector (no AC cables exiting the box)	INC	INC	EXC
13	Separate "kicker" / system startup batteries	INC	EXC	INC
14	AV mount to chassis (outside the box)	INC	EXC	INC
15	Internal cooling fans	INC	EXC	INC
16	Cooling system included in the ESC enclosure	INC	EXC	INC
17	Ballast exceeding 2kg	EXC	EXC	EXC
18	Hydraulic system (pumps, accumulator, manifold, servovalve, solenoid, actuators) other than servo valve(s) and actuator(s) for ERS control	EXC	EXC	EXC
19	Coolant pumps	EXC	EXC	EXC
20	Coolant fluids filter and restriction	EXC	EXC	EXC
21	Cooling system accumulator	EXC	EXC	EXC
22	MGU-K	INC	INC	EXC
23	MGU-K resolver	INC	INC	EXC
24	Mechanical transmission (single ratio) from MGU-K (shaft, gearbox, differential, basket, ...).	INC	INC	EXC
25	MGU-K to chassis mounting brackets	INC	EXC	EXC
26	Cooling pipes	INC	EXC	EXC
27	Electrical connections between ESC and MGU-K	INC	EXC	EXC
28	Liquids (except cell electrolyte)	EXC	EXC	EXC
29	ESC enclosure	INC	EXC	INC
30	Survival Cell	EXC	EXC	EXC

INC: INCLUDED: These parts must be included in the definition dossier.

EXC: EXCLUDED: These parts must be excluded from the definition-dossier.

GEARBOX

Item No	List of Gearbox functions/systems/components	GBX Weight/CoG
1	Gearbox internals including : Reverse assembly, output assembly, layshaft assembly, pinion shaft assembly, selection assembly and differential assembly	INC
2	External selection assembly	INC
3	Gearbox internals including : Lubrification system, Scavenge system	INC
4	Input shaft	INC
5	Gearbox Casing	INC
6	Bell housing (Including Gbx to ICE mounting points)	INC
7	Suspension clevis (including Gbox to clevis mounting points)	INC
8	Studs and/or nuts used for Gbx to ICE	EXC
9	Fluids	EXC

INC: INCLUDED: These parts must be included in the definition/weight/box/template/perimeter or dossier.

EXC: EXCLUDED: These parts must be excluded from the definition/weight/box/template/perimeter or dossier.

APPENDIX 3

COCKPIT AND SURVIVAL CELL

SURVIVAL CELL

Item No	List of survival cell functions/systems/components	Weight/CoG
1	Safety structure including the cockpit, the fuel tank compartment, the ES compartment, the ERS compartment	INC
2	All the fuel tank closing panels and fixations	INC
3	All built-in fixing components	INC
4	All ERS compartment panels and fixations	INC
5	Driver leg support and fixations	INC
6	ES closing panel	INC
7	Ballast mounted on the survival cell up to 5 kg	INC
8	Ballast mounted on the survival cell above 5 kg	EXC
9	All removable fixing components (crashbox, engine, sidepods...)	EXC
10	Windscreen and doors	EXC
11	All survival cell mechanical internal component (suspension related components, steering related components, pedals and mountings, seat, headrest, battery, electric related components...)	EXC

INC: INCLUDED: These parts must be included in the definition/weight/box/template/perimeter or dossier.

EXC: EXCLUDED: These parts must be excluded from the definition/weight/box/template/perimeter or dossier.

APPENDIX 4

POWER UNIT ENERGY FLOW

APPENDIX 4b

POWER UNIT ENERGY FLOW Maximum PowerTrain Power

Cars must be designed to target the following total maximum power curve (Sum of the 4 wheels power measured by driveshaft torque sensors) as follows:

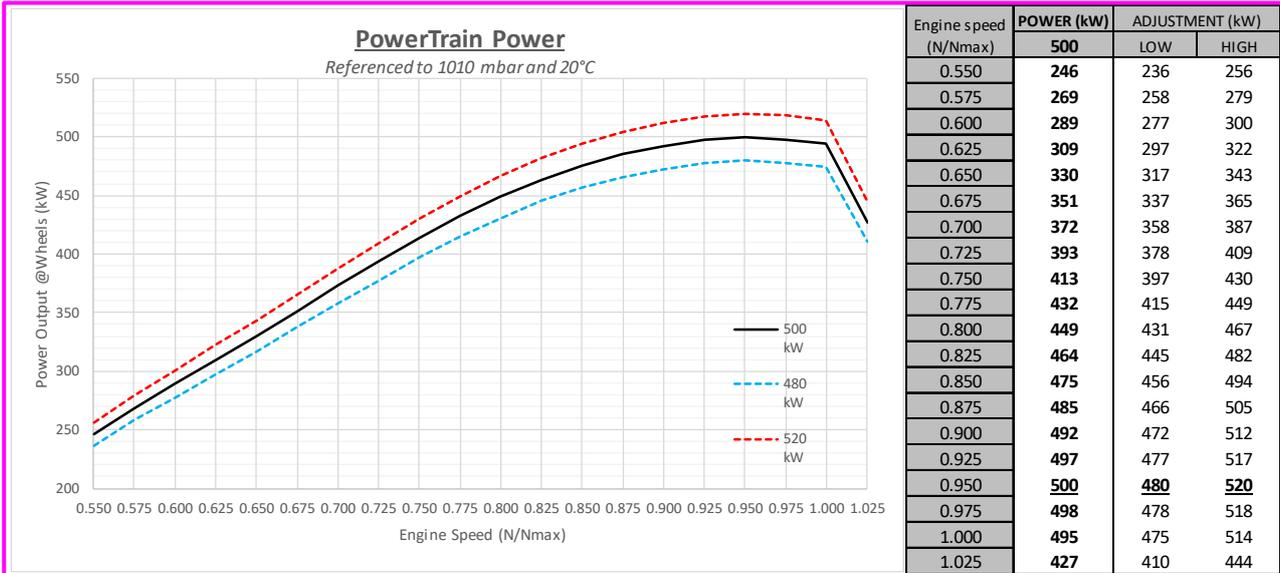

Details:

The PU performance will be checked on a dyno, and homologated. It will include:

- Power vs rpm. It is expected that power below 0.55xNmax is lower than 246 kW.
- Maximum rpm.

The maximum power is given for reference conditions: 1010 mbar and 20°C and 50 % relative Humidity.

If the ambient conditions naturally reduce performance, the maximum power curve will be corrected, at the beginning of each event, to the ambient conditions using the following correction factor:

$$\begin{aligned}
 & Pref = 1010 \text{ mbar}, Tref = 20^\circ\text{C} \\
 & Patmo \text{ (Atmospheric Pressure in mbar)}, Tatmo \text{ (Atmospheric Temperature in } ^\circ\text{C)}, Hatmo \text{ (Atmospheric relative Humidity in \%)} \\
 & \min \left(1; \frac{1}{\left(\frac{Pref}{\left(Patmo - 6.1121 * \exp \left\{ \left(18.678 - \frac{Tatmo}{234.5} \right) * \frac{Tatmo}{(257.14 + Tatmo)} \right\} * \frac{Hatmo}{100} \right) \right)^{1.169}} * \frac{(Tatmo + 273)}{(Tref + 273)} \right) }
 \end{aligned}$$

Power Unit usage is free (settings, modes) as far as the total power stays below the maximum power limit.

APPENDIX 5

SPECIFICATION FOR INTRUSION PANELS



FEDERATION INTERNATIONALE DE L'AUTOMOBILE

Specification for the Supplementary Panel
for LMH, LMP1 and LMP2

Version 1.1

21 January 2020

General

The panel shall be constructed from Torayca T1000G (or T1100G or T1100S) and Toyobo High Modulus Zylon (PBO) fibres, impregnated with a toughened, elevated cure temperature, epoxy resin system. If different resins are used for the T1000G (or T1100G or T1100S) and Zylon reinforced plies, they must be cocurable. The construction of the panel shall be quasi isotropic and shall avoid darts, joins or gaps in any ply, apart from those required to cover complex geometry, cut outs for wiring and side impact structures. Rebates shall be permitted in the outer four Zylon plies only, for the attachment of external bodywork. Any joins required in each ± 45 degree ply, to cater for a finite material roll width, shall overlap by at least 10mm and be staggered through the laminate, to avoid super-imposing. The panel must be cured to the manufacturer's recommended cure cycle. If the panel will not be integrated (laminated) in the survival cell, the panel will be bonded to the chassis over the entire surface area with the prescribed film or paste adhesive.

Zylon HM – 300gsm

Minimum average weight [285]gsm, 6K fibres per tow, in a 2 X 2 twill weave style, impregnated with an epoxy resin.

T1000G or T1100G or T1100S – 280gsm

Minimum average weight [269]gsm, 12K fibres per tow, 2 X 2 twill weave or 5 harness satin weave, impregnated with an epoxy resin.

Matrix System

MTM49-3 or Cycom 2020 epoxy resin or compliant materials listed below.

Adhesive (to chassis)

Film adhesive 150gsm 3M AF163-2, or paste adhesive 3M 9323 B/A, or paste adhesive 3M DP460.

Stacking Sequence (0 degree represents longitudinal axis of the chassis)

Outer surface

1 ply T1000G or T1100G or T1100S (0/90)

7 plies Zylon (± 45 , 0/90, ± 45 , 0/90, ± 45 , 0/90, ± 45)

1 ply T1000G or T1100G or T1100S (0/90)

Inner surface

Thickness

The minimum thickness of the cured panel, excluding the adhesive, shall be [3.0]mm.

Area Weight

The minimum area weight of the cured panel, excluding the adhesive, shall be [8700]gsm.



FEDERATION INTERNATIONALE DE L'AUTOMOBILE

Voids

The panel shall be essentially void free.

Examples of Compliant Materials

1. Supplied by Cytec

Zylon HM-300gsm/2x2 twill with Cycom2020 epoxy resin (NOM 42% by weight)

T1000G-12K 280gsm/2x2twill or 5 harness weave with Cycom2020 epoxy resin (NOM 42% by weight)

2. Supplied by ACG

Zylon HM-300gsm/2x2 twill with MTM49-3 epoxy resin (NOM 43% by weight)

T1000G-12K 280gsm/2x2twill or 5 harness weave with MTM49-3 epoxy resin (NOM 40% by weight)

3. Supplied by TenCate

Zylon HM-300gsm/2x2 twill with E750-02 epoxy resin (NOM 42% by weight)

T1000G-12K 280gsm/2x2twill or 5 harness weave with E750-02 epoxy resin (NOM 42% by weight)

4. Supplied by Delta Tech S.p.a

Zylon HM-300gsm/2x2 twill with DT195N epoxy resin (NOM 42% by weight)

T1000G-12K 280gsm/2x2twill or 5 harness weave with DT195N epoxy resin (NOM 42% by weight)

APPENDIX 6

LIFTING DEVICES

General installation

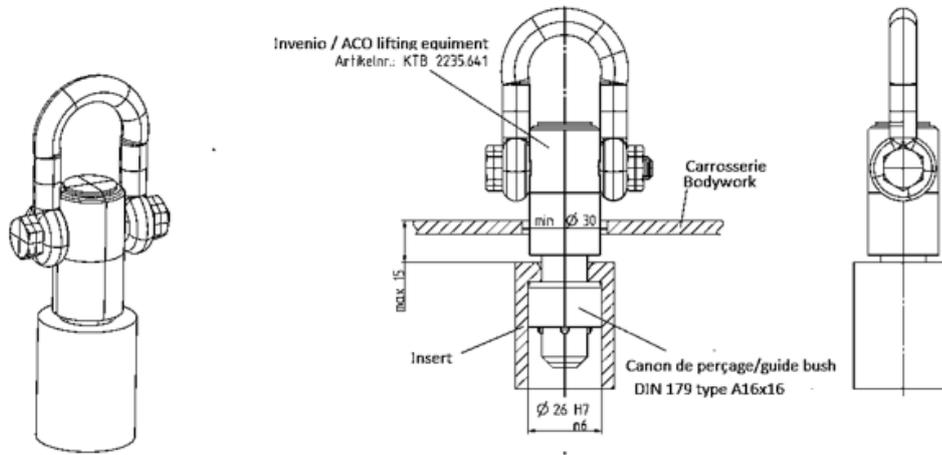

Insert detail

