



FEDERATION INTERNATIONALE DE L'AUTOMOBILE

Homologation N°

SH.055.18-T-6

Date

07.12.2018

**FICHE DE PRESENTATION DES HARNAIS DE SECURITE (NORME FIA 8853-2016)
PRESENTATION FORM FOR SAFETY HARNESSSES (FIA STANDARD 8853-2016)**

1. GENERALITES / GENERAL

101. CONSTRUCTEUR / MANUFACTURER

SCHROTH SAFETY PRODUCTS GMBH

- a) Adresse
Address **IM OHL 14, 59757 ARNSBERG / GERMANY**
- b) Téléphone
Phone **+49 2932 9742 0**
- c) E-mail
E-mail **GERMANY@EU.SCHROTH.COM**

102. PHOTO DU HARNAIS COMPLET / PICTURE OF THE COMPLETE HARNESS



103. MODELE DU HARNAIS / HARNESS MODEL

- a) Modèle
Model **PROFI II-6H**
- (6-POINT HARNESS BELT WITH 2" / 3" SHOULDER BELT COMBINATION AND WITH 2" PELVIC STRAPS)**

Marque
Make

SCHROTH SAFETY PRODUCTS
GMBH

Modèle
Model

PROFI II-6H
(6-POINT HARNESS BELT WITH 2"/3"
SHOULDER BELT COMBINATION
AND WITH 2" PELVIC STRAPS)

Homologation N°

SH.055.18-T-6

2. DETAILS DU HARNAIS / DETAILS OF HARNESS

201. SANGLES / STRAPS

	Matériau Material	Largeur Width (mm)	Position Position
201.01 GU 19.10.x (x=colour key)	polyester	3"	lower shoulder straps shoulder top strap 2"/3" combination
201.02 GU 10.7.x (x=colour key)	polyester	1"	crotch strap loops
201.03 GU 11.6.x (x=colour key)	polyester	2"	pelvic straps crotch straps upper shoulder straps
201.04			
201.05			
201.06			

202. VUES DES PIÈCES DE FIXATION/ ATTACHMENTS VIEWS

A1-1) Position / Position : right shoulder strap

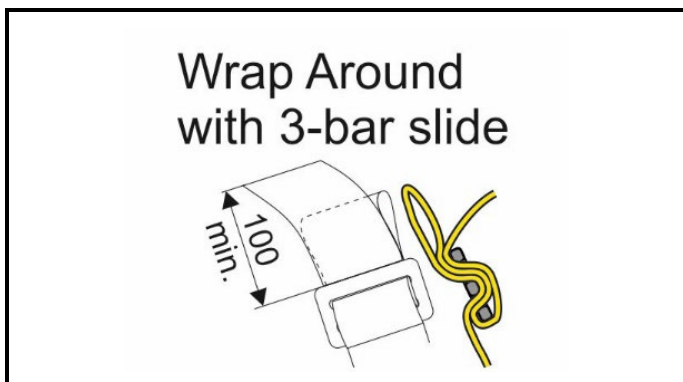

A1-2) Position / Position : left shoulder strap

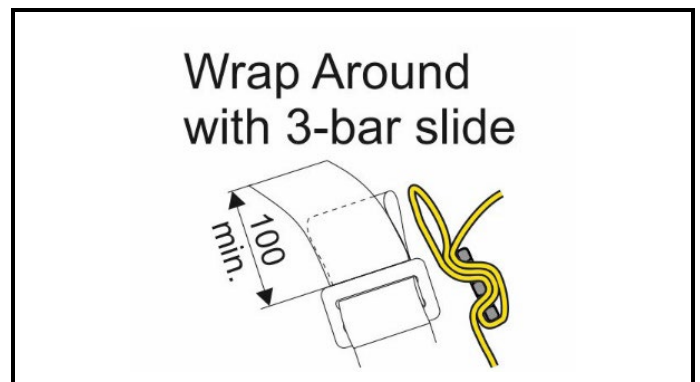

Marque
Make

SCHROTH SAFETY PRODUCTS
GMBH

Modèle
Model

PROFI II-6H
(6-POINT HARNESS BELT WITH 2"/3"
SHOULDER BELT COMBINATION
AND WITH 2" PELVIC STRAPS)

Homologation N°

SH.055.18-T-6

A1-3) Position / Position : right pelvic strap

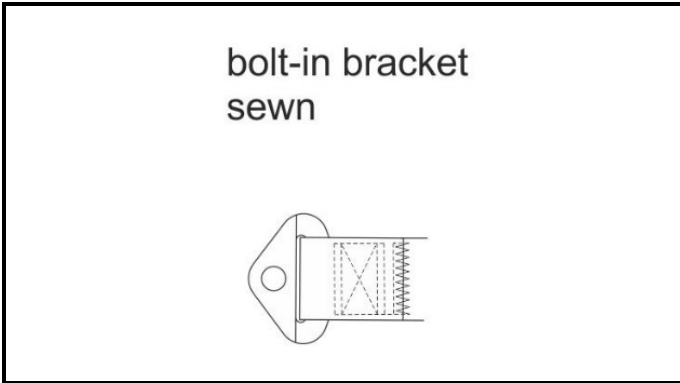

A1-4) Position / Position : left pelvic strap

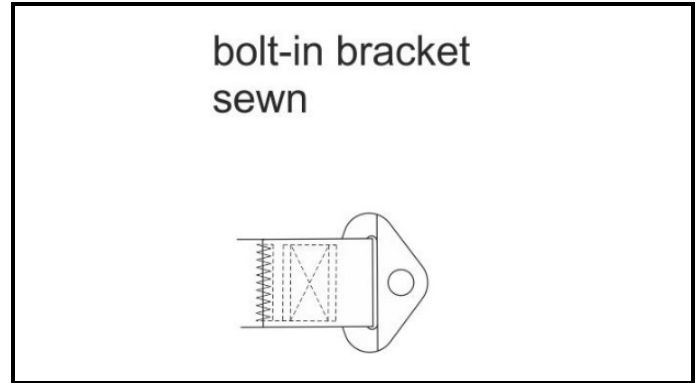

A1-5) Position / Position : right crotch strap

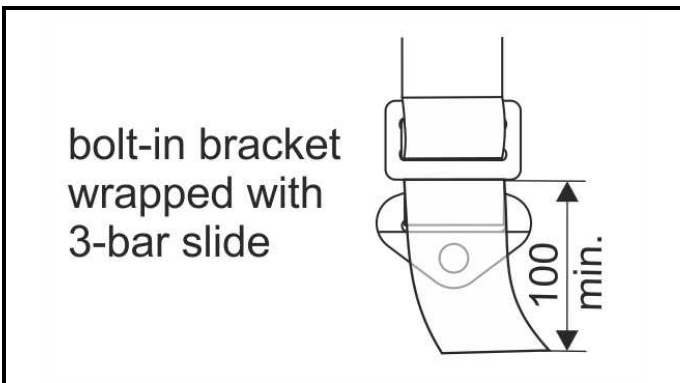

A1-6) Position / Position : left crotch strap

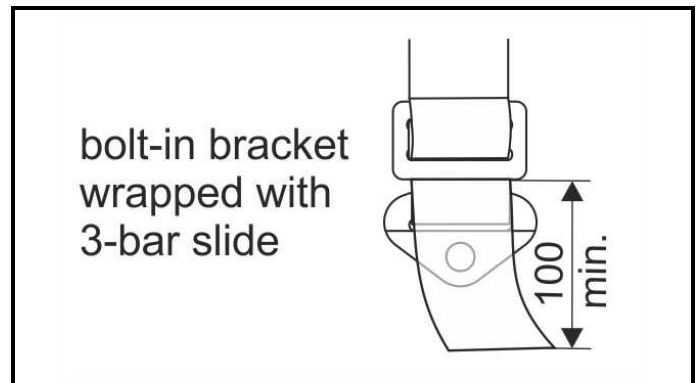

203. VUES DES DISPOSITIFS DE REGLAGE/ ADJUSTING DEVICES VIEWS

A2-1) Position / Position : 3" right shoulder strap



A2-2) Position / Position : 3" left shoulder strap



A2-3) Position / Position : 2" right pelvic



A2-4) Position / Position : 2" left pelvic



Marque
Make **SCHROTH SAFETY PRODUCTS
GMBH**

Modèle
Model **PROFI II-6H
(6-POINT HARNESS BELT WITH 2"/3"
SHOULDER BELT COMBINATION
AND WITH 2" PELVIC STRAPS)**

Homologation N°

SH.055.18-T-6

204. BOUCLE / BUCKLE

204.1 Boucle à libération complète / Full release buckle Material

Oui / Yes

Non / No



A3-1) Vue de la boucle / Buckle view

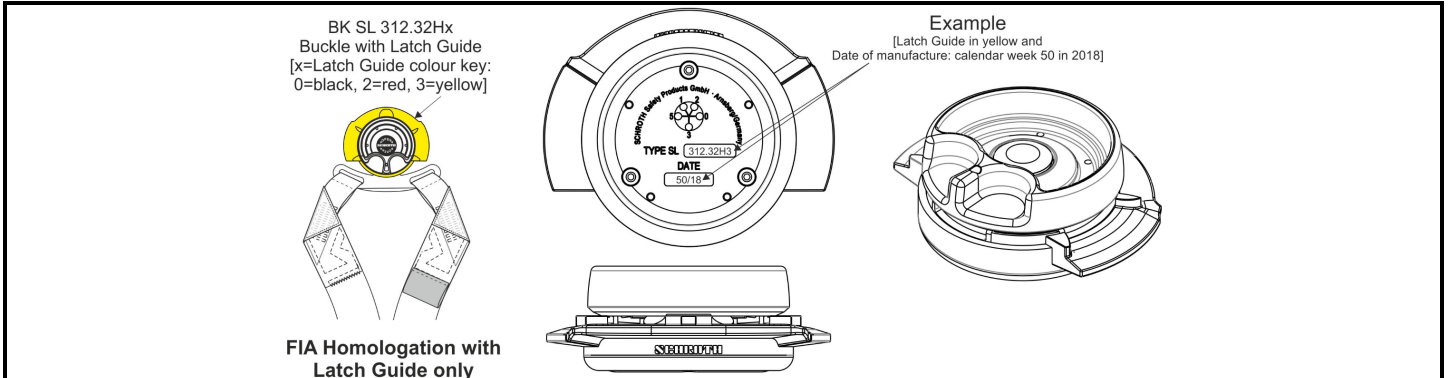

3. ETIQUETTES D'HOMOLOGATION ET DE IDENTIFICATION / HOMOLOGATION AND IDENTIFICATION LABELS

301. ETIQUETTES / LABELS

a) Dimensions [mm]
Dimensions [mm]

Etiquette d'homologation
Homologation label
height 44 x width 84 (+stitching areas)

Etiquette d'identification
Identification label
height 40 (+ stitching areas) x width 44

B1-1) Etiquette d'homologation et autocollant FIA cousus sur le harnais
Homologation label and FIA sticker stitched on the harness

B1-2) Etiquette d'homologation cousus sur le harnais
Homologation label stitched on the harness

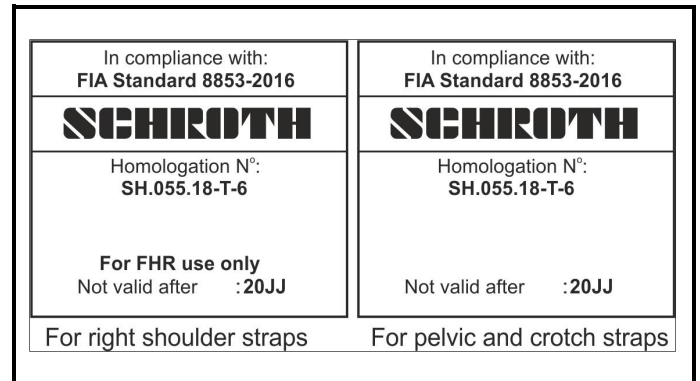
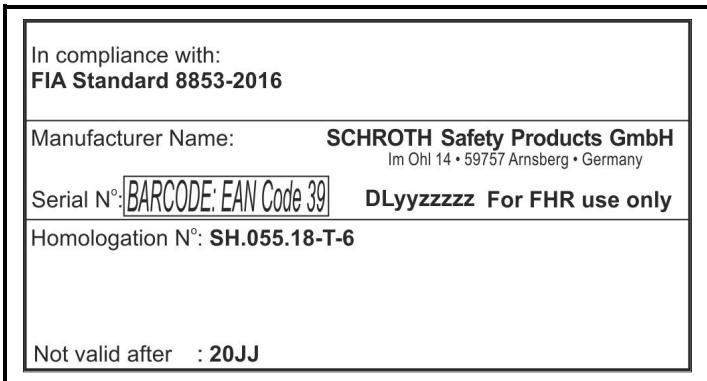

B1-3) Marquages pour boucle a libération complète
Full release buckle marking

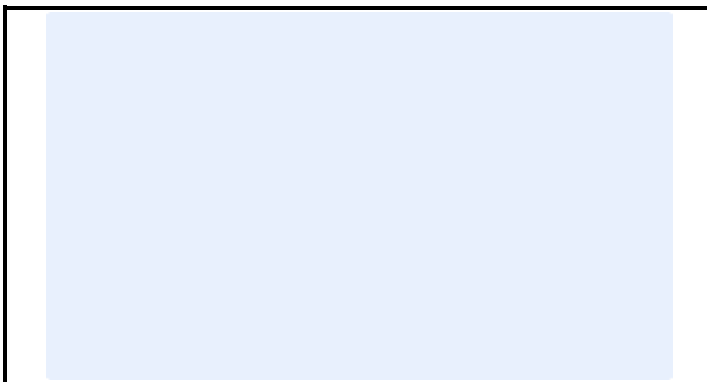

Marque
Make

SCHROTH SAFETY PRODUCTS
GMBH

Modèle
Model

PROFI II-6H
(6-POINT HARNESS BELT WITH 2"/3"
SHOULDER BELT COMBINATION
AND WITH 2" PELVIC STRAPS)

Homologation N°

SH.055.18-T-6

INFORMATIONS COMPLEMENTAIRES / COMPLEMENTARY INFORMATION

ALTERNATIVE **SHOULDER BELT** OPTIONS

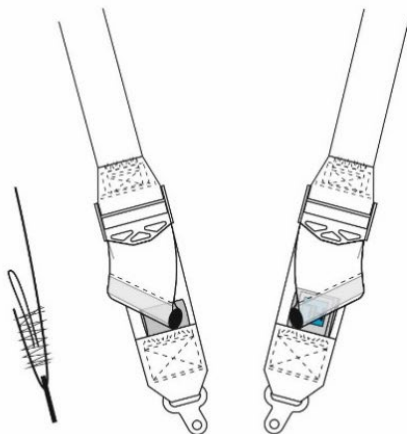

- 2" SCHROTH Racing logo
- 2"/3" cover
- small SCHROTH logo on top of adjusting device
- pull tabs SCHROTH Velcro
- pull loop sewn
- magnets with cover

SHOULDER STRAP – LABEL SEWN (optional)



Marque
Make

SCHROTH SAFETY PRODUCTS
GMBH

Modèle
Model

PROFI II-6H
(6-POINT HARNESS BELT WITH 2"/3"
SHOULDER BELT COMBINATION
AND WITH 2" PELVIC STRAPS)

SH.055.18-T-6

SHOULDER STRAP

- 2"/3" cover (optional)
- Schroth logo (optional)



SHOULDER AND PELVIC – PULL-TAB SEWN or VELCRO (optional)



SHOULDER STRAP – PULL-LOOP (optional, color can vary)



Marque
Make

SCHROTH SAFETY PRODUCTS
GMBH

Modèle
Model

PROFI II-6H
(6-POINT HARNESS BELT WITH 2"/3"
SHOULDER BELT COMBINATION
AND WITH 2" PELVIC STRAPS)

SH.055.18-T-6

SHOULDER STRAP near TONGUE – MAGNETS into SEWN POCKET (optional)



PELVIC STRAP near TONGUE – SEWN LOOP



CROTCH STRAPS – ALTERNATIVE ATTACHMENT (snap hook)

