



# FEDERATION INTERNATIONALE DE L'AUTOMOBILE

Homologation N°

**SH.015.17-T-6**

Date

28.01.2022

FICHE DE PRESENTATION DES HARNAIS DE SECURITE (NORME FIA 8853-2016)  
PRESENTATION FORM FOR SAFETY HARNESSSES (FIA STANDARD 8853-2016)

## 1. GENERALITES / GENERAL

### 101. CONSTRUCTEUR / MANUFACTURER

SCHROTH SAFETY PRODUCTS GMBH

- a) Adresse  
Address IM OHL 14, 59757 ARNSBERG / GERMANY
- b) Téléphone  
Phone +49 2932 9742 0
- c) E-mail  
E-mail GERMANY@EU.SCHROTH.COM

### 102. PHOTO DU HARNAIS COMPLET / PICTURE OF THE COMPLETE HARNESS



### 103. MODELE DU HARNAIS / HARNESS MODEL

- a) Modèle  
Model **ENDURO 2X2**
- (6-POINT HARNESS BELT WITH 2" SHOULDER BELTS FOR FHR USE ONLY AND WITH 2" PELVIC STRAPS)**

Marque  
Make

SCHROTH SAFETY PRODUCTS  
GMBH

Modèle  
Model

ENDURO 2X2  
(6-POINT HARNESS BELT WITH 2"  
SHOULDER BELTS FOR FHR USE  
ONLY AND WITH 2" PELVIC STRAPS)

SH.015.17-T-6

## 2. DETAILS DU HARNAIS / DETAILS OF HARNESS

### 201. SANGLES / STRAPS

	Matériau Material	Largeur Width (mm)	Position Position
201.01 GU 11.6.x (x=colour key)	polyester	2"	shoulder straps crotch straps
201.02 GU 10.7.x (x=colour key)	polyester	1"	crotch strap loops
201.03 GU 15.7.x (x=colour key)	polyester	2"	pelvic straps
201.04			
201.05			
201.06			

### 202. VUES DES PIECES DE FIXATION/ ATTACHMENTS VIEWS

A1-1) Position / Position : **right shoulder strap**

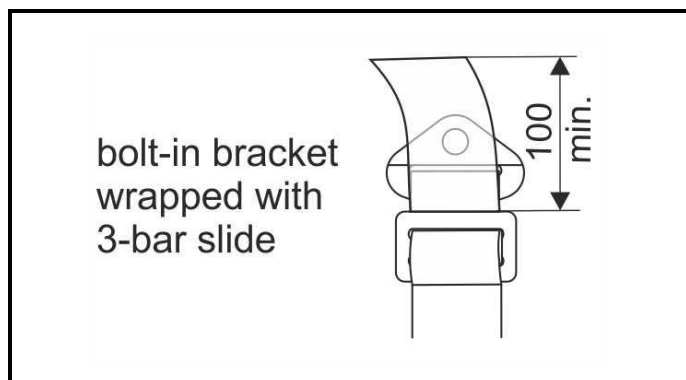

A1-2) Position / Position : **left shoulder strap**

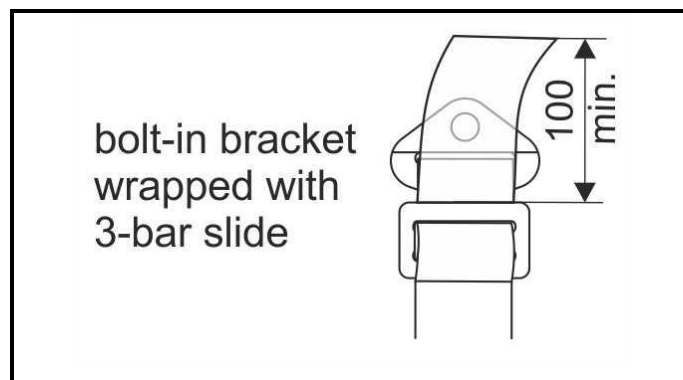

Marque **SCHROTH SAFETY PRODUCTS**  
 Make **GMBH**

Modèle  
 Model

**ENDURO 2X2**  
**(6-POINT HARNESS BELT WITH 2"**  
**SHOULDER BELTS FOR FHR USE**  
**ONLY AND WITH 2" PELVIC STRAPS)**

**SH.015.17-T-6**

A1-3) Position / Position : right pelvic strap

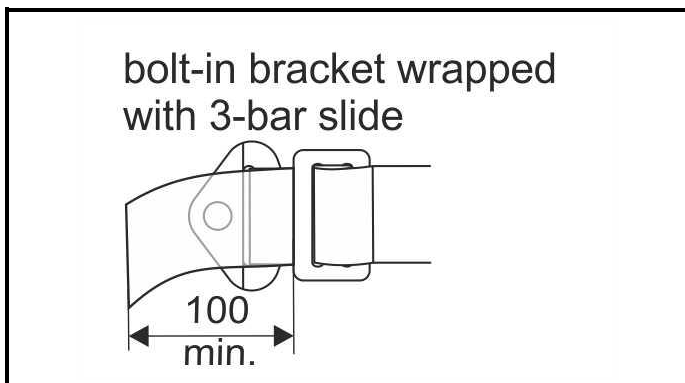

A1-4) Position / Position : left pelvic strap

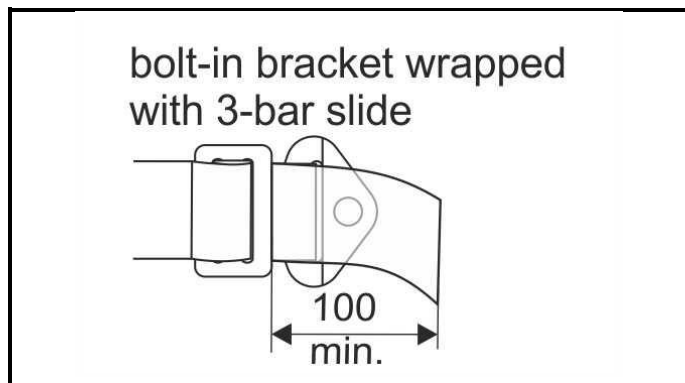

A1-5) Position / Position : right crotch strap

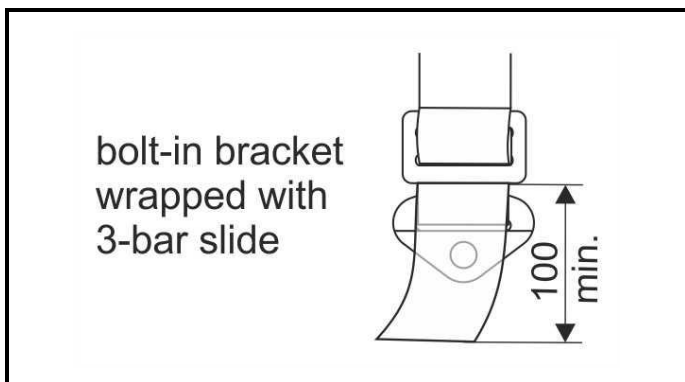

A1-6) Position / Position : left crotch strap

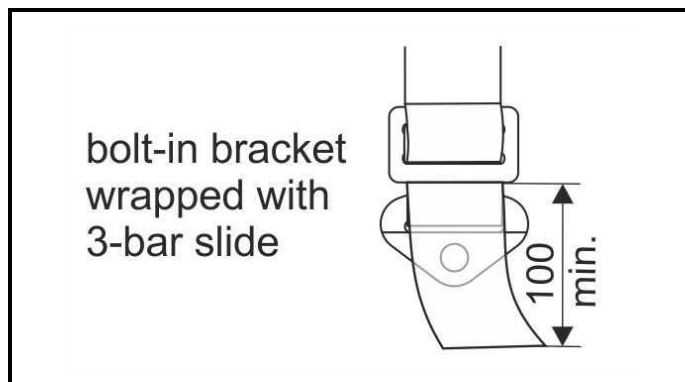

**203. VUES DES DISPOSITIFS DE REGLAGE / ADJUSTING DEVICES VIEWS**

A2-1) Position / Position : 2" right and left shoulder (optional release strap)

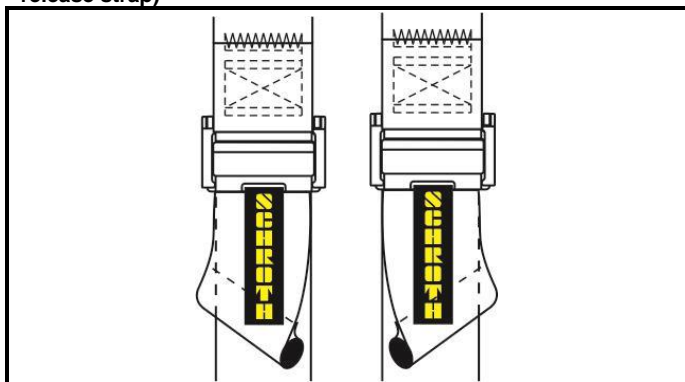

A2-2) Position / Position : 2" right and left crotch strap (optional release strap)

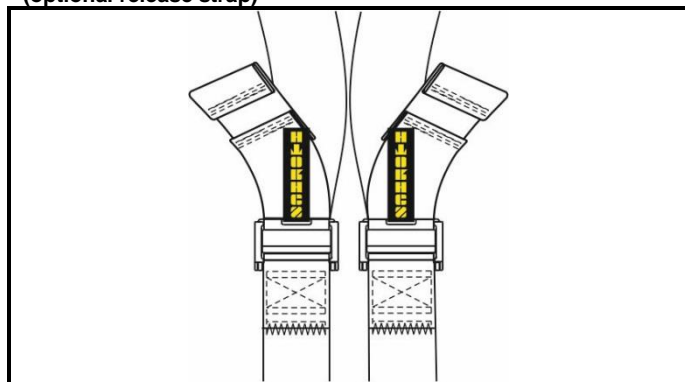

A2-3) Position / Position : 2" right pelvic adjuster latch (opt. release strap) pull-down configuration

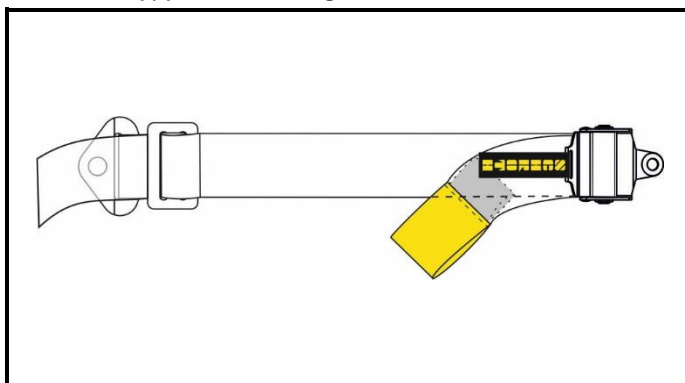

A2-4) Position / Position : 2" left pelvic adjuster latch (opt. release strap) pull-down configuration

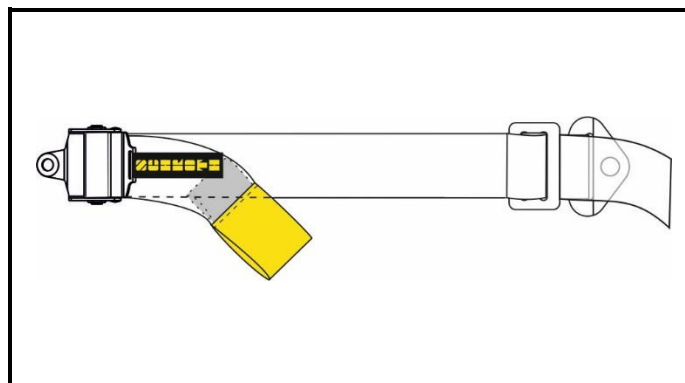

Marque  
Make **SCHROTH SAFETY PRODUCTS  
GMBH**

Modèle  
Model **ENDURO 2X2**

**(6-POINT HARNESS BELT WITH 2"  
SHOULDER BELTS FOR FHR USE  
ONLY AND WITH 2" PELVIC STRAPS)**

**SH.015.17-T-6**

### 204. BOUCLE / BUCKLE

204.1 Boucle à libération complète / Full release buckle Material

Oui / Yes



Non / No



A3-1) Vue de la boucle / Buckle view

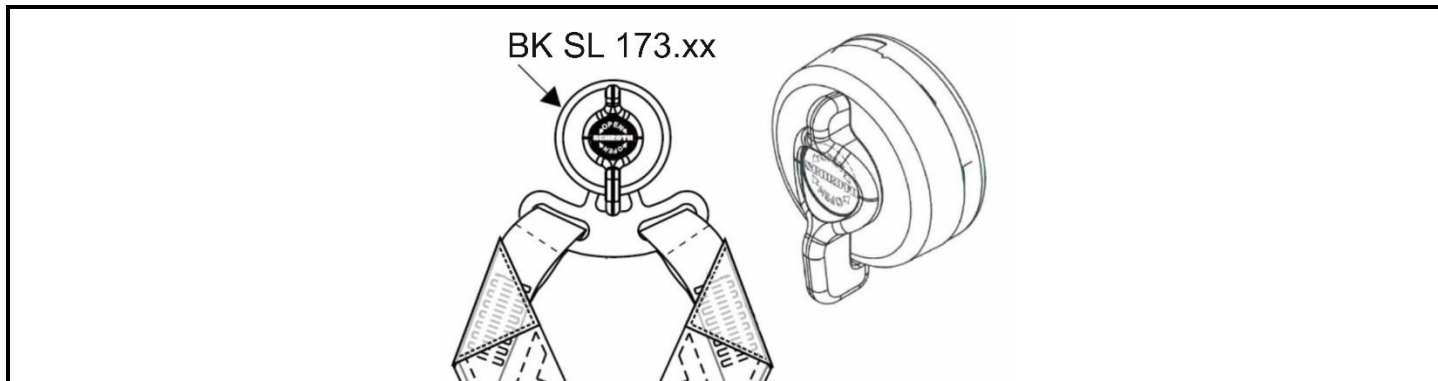

### 3. ETIQUETTES D'HOMOLOGATION ET DE IDENTIFICATION / HOMOLOGATION AND IDENTIFICATION LABELS

#### 301. ETIQUETTES / LABELS

a) Dimensions [mm]  
Dimensions [mm]

Etiquette d'homologation  
Homologation label

height 44 x width 84 (+stitching areas)

Etiquette d'identification  
Identification label

height 40 (+ stitching areas) x width 44

B1-1) Etiquette d'homologation et autocollant FIA cousus sur le harnais  
Homologation label and FIA sticker stitched on the harness

In compliance with: <b>FIA Standard 8853-2016</b>	
Manufacturer Name:	<b>SCHROTH Safety Products GmbH</b> <small>Im Ohl 14 • 59757 Arnsberg • Germany</small>
Serial N°:	<b>BARCODE: EAN Code 39 DDyyzzzzz For FHR use only</b>
Homologation N°:	<b>SH.015.17-T-6</b>
Not valid after : <b>20JJ</b>	

B1-2) Etiquette d'homologation cousus sur le harnais  
Homologation label stitched on the harness

In compliance with: <b>FIA Standard 8853-2016</b>	In compliance with: <b>FIA Standard 8853-2016</b>
<b>SCHROTH</b>	<b>SCHROTH</b>
Homologation N°: <b>SH.015.17-T-6</b>	Homologation N°: <b>SH.015.17-T-6</b>
<b>For FHR use only</b> Not valid after : <b>20JJ</b>	Not valid after : <b>20JJ</b>
For right shoulder straps	For pelvic and crotch straps

B1-3) Marquages pour boucle a libération complète  
Full release buckle marking

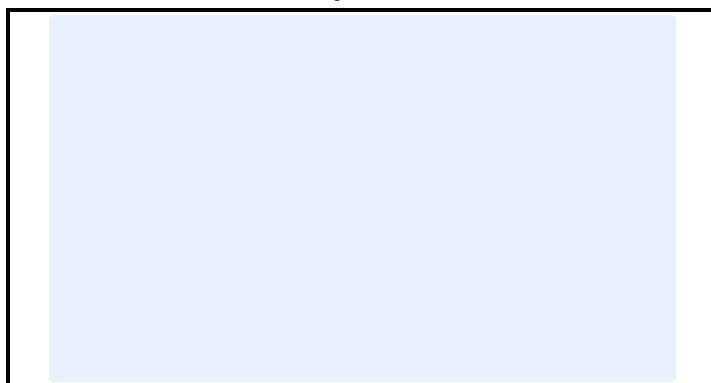







Marque **SCHROTH SAFETY PRODUCTS**  
 Make **GMBH**

Modèle **ENDURO 2X2**  
 Model **(6-POINT HARNESS BELT WITH 2" SHOULDER BELTS FOR FHR USE ONLY AND WITH 2" PELVIC STRAPS)**

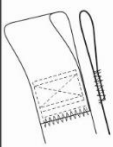
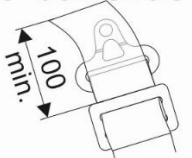

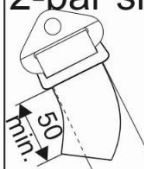
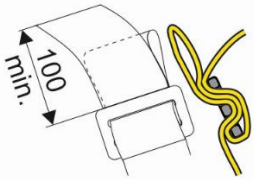

**SH.015.17-T-6**

**INFORMATIONS COMPLEMENTAIRES / COMPLEMENTARY INFORMATION**

**ALTERNATIVE ATTACHMENTS – APPLICABLE ON SHOULDER and CROTCH STRAPS**

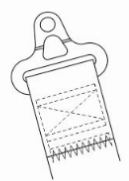
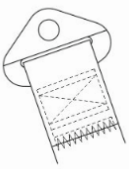
Wrap Around with 2-bar slide 	Sewn Loop 	B 64.20.xx wrapped w. 3-bar slide 	B 50.xx.yy sewn 	B 24.xx.yy sewn 	B 24.xx.yy wrapped with 2-bar slide 
Wrap Around with 3-bar slide 	B 154 sewn 	BK B 18.xx.yy sewn 	BK B 15 wrapped w. 2-bar slide 	BK B 15 wrapped w. 3-bar slide 	

**ALTERNATIVE ATTACHMENTS – APPLICABLE ON PELVIC STRAPS**

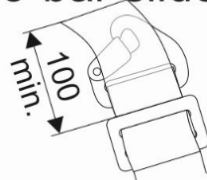
B 64.20.xx sewn 	B 24.xx.yy sewn 	B 154 sewn 	B 23 A sewn 	B 43 A sewn 	BK B 15 wrapped w. 3-bar slide 
--	--	---	--	--	---

**ALTERNATIVE CROTCH STRAP WITHOUT ADJUSTER**

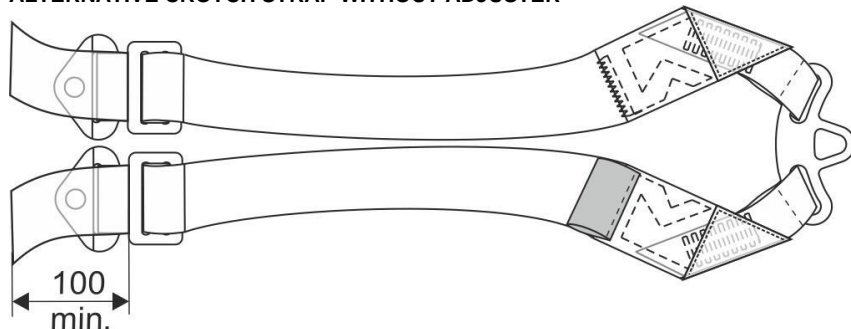

Marque  
Make SCHROTH SAFETY PRODUCTS  
GMBH

Modèle  
Model

ENDURO 2X2  
(6-POINT HARNESS BELT WITH 2"  
SHOULDER BELTS FOR FHR USE  
ONLY AND WITH 2" PELVIC STRAPS)

**SH.015.17-T-6**

**OPTIONAL PULL-TAB ON ADJUSTERS (with velcro)**



**ALTERNATIVE BUCKLE**

BK SL 163.xx

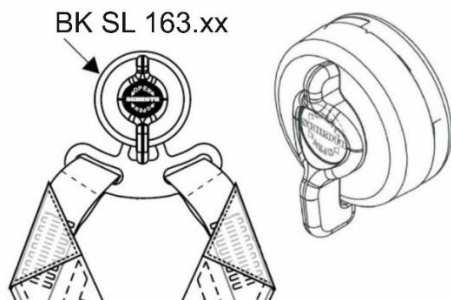

**ALTERNATIVE BUCKLE LATCH GUIDE**



**ALTERNATIVE ADJUSTER WITH TONGUE – PELVIC STRAP**



Marque  
Make

SCHROTH SAFETY PRODUCTS  
GMBH

Modèle  
Model

ENDURO 2X2  
(6-POINT HARNESS BELT WITH 2"  
SHOULDER BELTS FOR FHR USE  
ONLY AND WITH 2" PELVIC STRAPS)

SH.015.17-T-6

**Serial Number (Bar Code) sticker placed on the homologation label.**

**FIA Label Information:**  
additional Barcode with serial number  
on self-destructing label (sticker):  
length: 45 mm, height: 5 mm

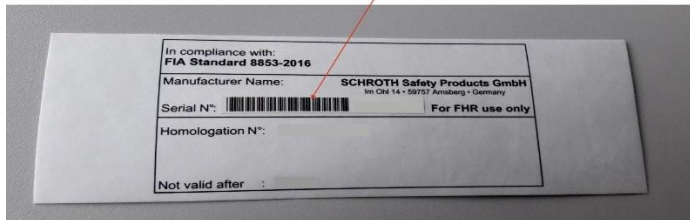

**Alternative Shoulder strap Options**

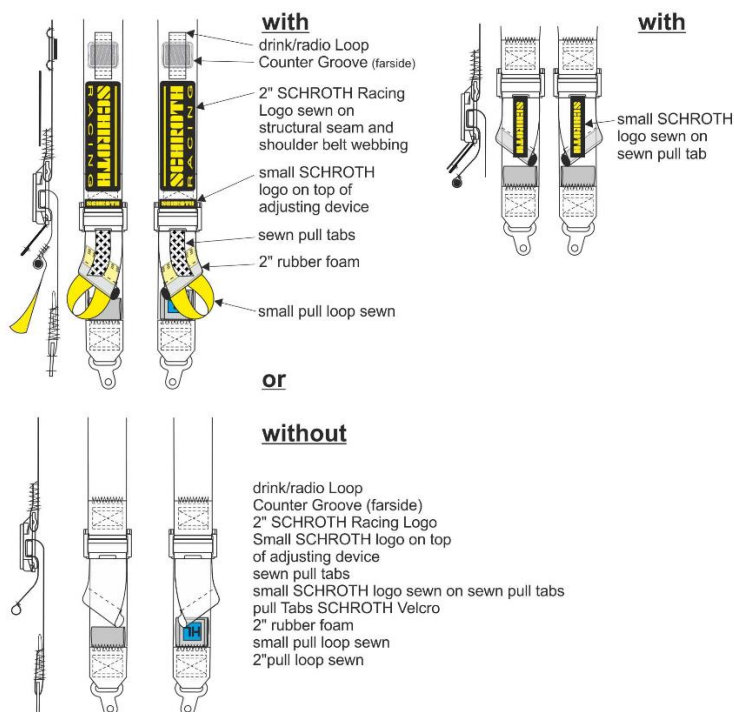

**Alternative Crotch strap Options**

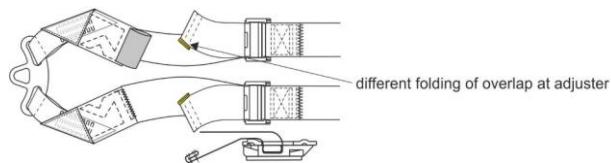

**Alternative Pelvic strap Options**

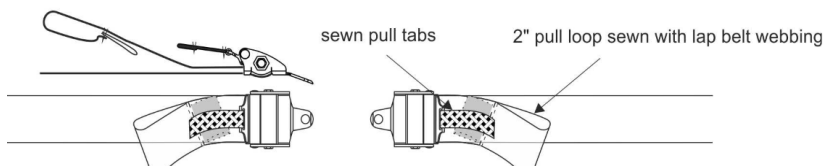

Marque  
Make

SCHROTH SAFETY PRODUCTS  
GMBH

Modèle  
Model

ENDURO 2X2  
(6-POINT HARNESS BELT WITH 2"  
SHOULDER BELTS FOR FHR USE  
ONLY AND WITH 2" PELVIC STRAPS)

**SH.015.17-T-6**

### Alternative Structural Seams on Crotch Straps (N 135.184 and N 136.184)

