



FEDERATION INTERNATIONALE DE L'AUTOMOBILE

Homologation N°

SH.014.17-T-6

Date

28.01.2022

**FICHE DE PRESENTATION DES HARNAIS DE SECURITE (NORME FIA 8853-2016)
PRESENTATION FORM FOR SAFETY HARNESSSES (FIA STANDARD 8853-2016)**

1. GENERALITES / GENERAL

101. CONSTRUCTEUR / MANUFACTURER

SCHROTH SAFETY PRODUCTS GMBH

- a) Adresse
Address **IM OHL 14, 59757 ARNSBERG / GERMANY**
- b) Téléphone
Phone **+49 2932 9742 0**
- c) E-mail
E-mail **GERMANY@EU.SCHROTH.COM**

102. PHOTO DU HARNAIS COMPLET / PICTURE OF THE COMPLETE HARNESS



103. MODELE DU HARNAIS / HARNESS MODEL

- a) Modèle
Model **SCHROTH T-BAR 2X2**
- (6-POINT HARNESS BELT WITH 2" SHOULDER BELTS FOR FHR USE ONLY AND WITH 2" PELVIC STRAPS)**

Marque
Make

SCHROTH SAFETY PRODUCTS
GMBH

Modèle
Model

SCHROTH T-BAR 2X2
(6-POINT HARNESS BELT WITH 2"
SHOULDER BELTS FOR FHR USE
ONLY AND WITH 2" PELVIC STRAPS)

SH.014.17-T-6

2. DETAILS DU HARNAIS / DETAILS OF HARNESS

201. SANGLES / STRAPS

	Matériau Material	Largeur Width (mm)	Position Position
201.01 GU 11.6.x (x=colour key)	polyester	2"	shoulder straps pelvic straps crotch straps
201.02 GU 10.7.x (x=colour key)	polyester	1"	crotch strap loops
201.03			
201.04			
201.05			
201.06			

202. VUES DES PIÈCES DE FIXATION/ ATTACHMENTS VIEWS

A1-1) Position / Position : **right shoulder strap**

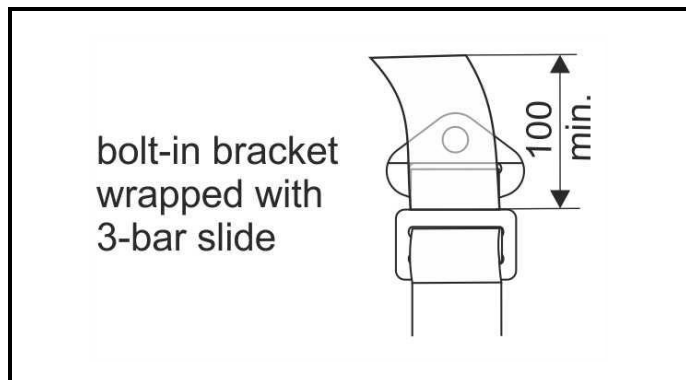

A1-2) Position / Position : **left shoulder strap**

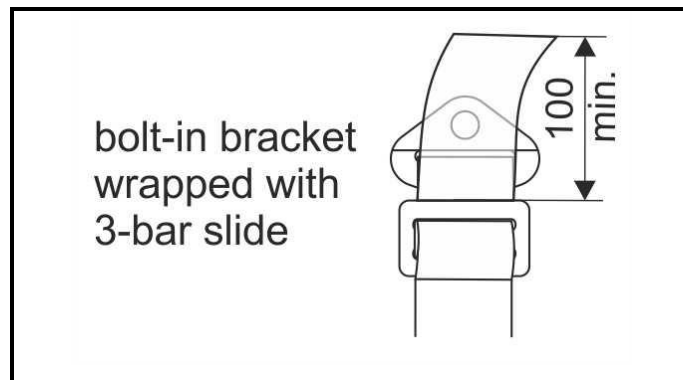

Marque **SCHROTH SAFETY PRODUCTS**
 Make **GMBH**

Modèle
 Model

SCHROTH T-BAR 2X2
(6-POINT HARNESS BELT WITH 2"
SHOULDER BELTS FOR FHR USE
ONLY AND WITH 2" PELVIC STRAPS)

SH.014.17-T-6

A1-3) Position / Position : **right pelvic strap**

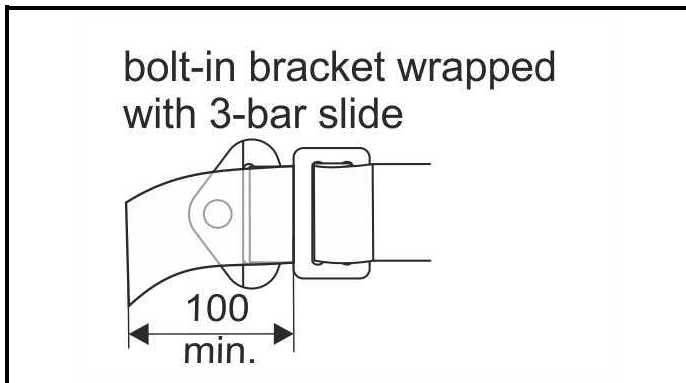

A1-4) Position / Position : **left pelvic strap**

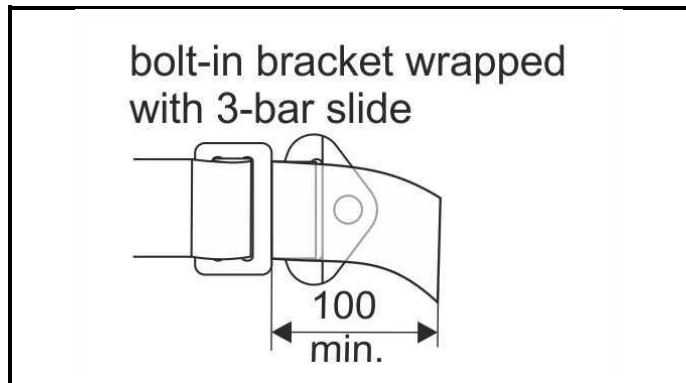

A1-5) Position / Position : **right crotch strap**

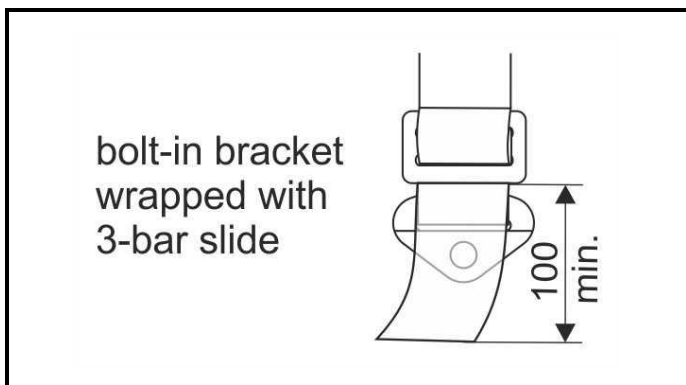

A1-6) Position / Position : **left crotch strap**

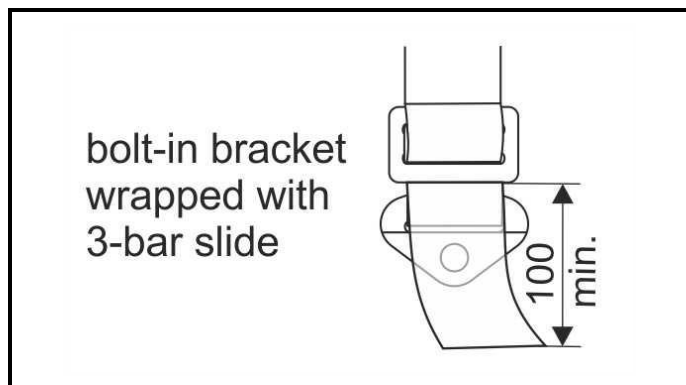

203. VUES DES DISPOSITIFS DE REGLAGE/ ADJUSTING DEVICES VIEWS

A2-1) Position / Position : **2" right and left shoulder strap (optional release strap)**

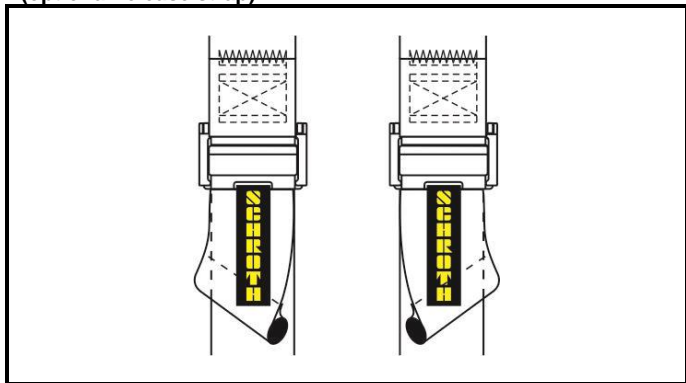

A2-2) Position / Position : **2" right and left crotch strap (optional release strap)**

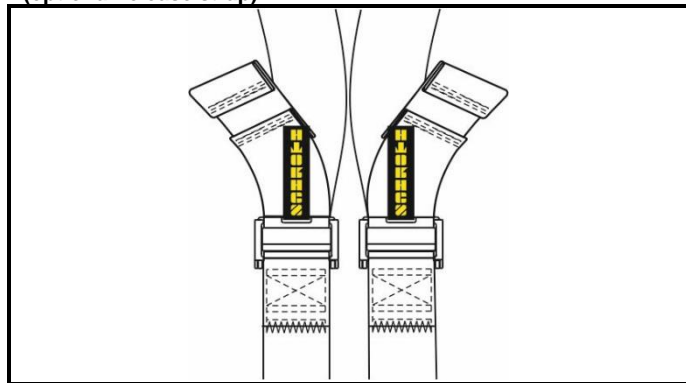

A2-3) Position / Position : **2" right pelvic adjuster (opt. release strap) pull-down or pull-up configurations**

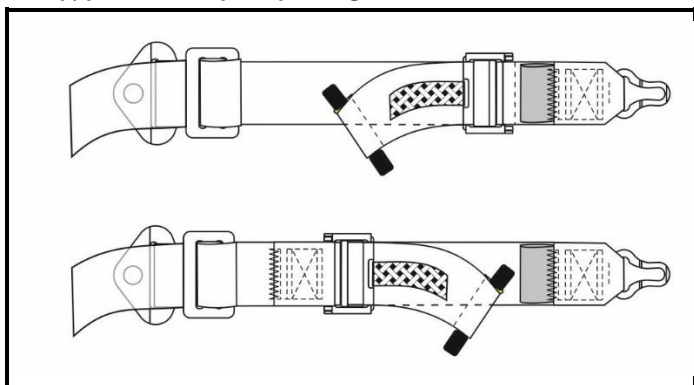

A2-4) Position / Position : **2" left pelvic adjuster (opt. release strap) pull-down or pull-up configurations**

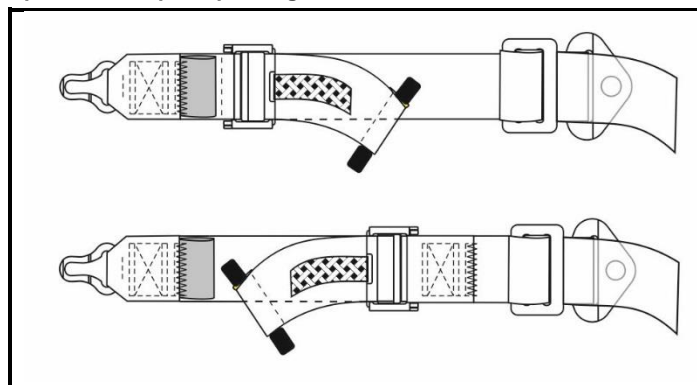

Marque
Make **SCHROTH SAFETY PRODUCTS
GMBH**

Modèle
Model

SCHROTH T-BAR 2X2
(6-POINT HARNESS BELT WITH 2"
SHOULDER BELTS FOR FHR USE
ONLY AND WITH 2" PELVIC STRAPS)

SH.014.17-T-6

204. BOUCLE / BUCKLE

204.1 Boucle à libération complète / Full release buckle Material

Oui / Yes



Non / No



A3-1) Vue de la boucle / Buckle view

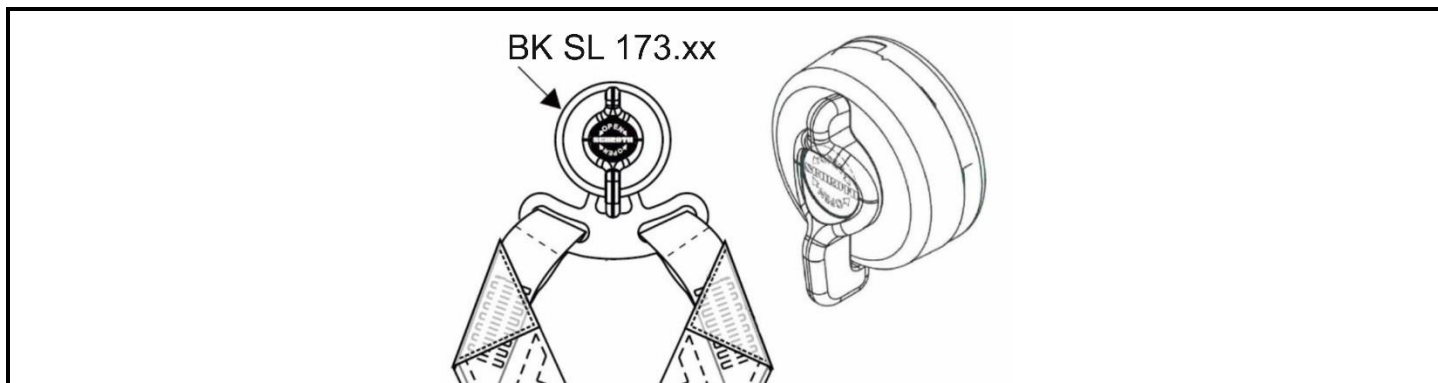

3. ETIQUETTES D'HOMOLOGATION ET DE IDENTIFICATION / HOMOLOGATION AND IDENTIFICATION LABELS

301. ETIQUETTES / LABELS

a) Dimensions [mm]
Dimensions [mm]

Etiquette d'homologation
Homologation label

height 44 x width 84 (+stitching areas)

Etiquette d'identification
Identification label

height 40 (+ stitching areas) x width 44

B1-1) Etiquette d'homologation et autocollant FIA cousus sur le harnais
Homologation label and FIA sticker stitched on the harness

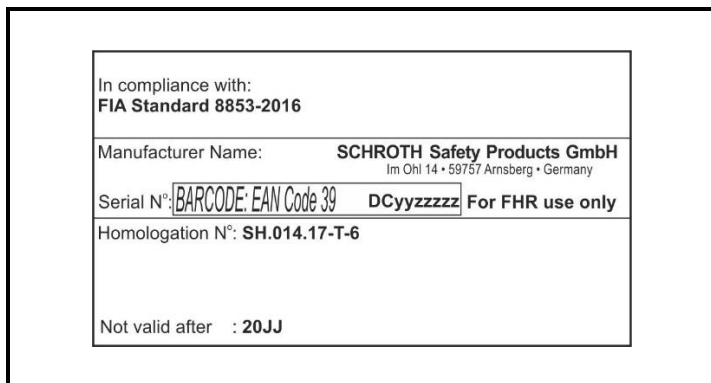

B1-2) Etiquette d'homologation cousus sur le harnais
Homologation label stitched on the harness

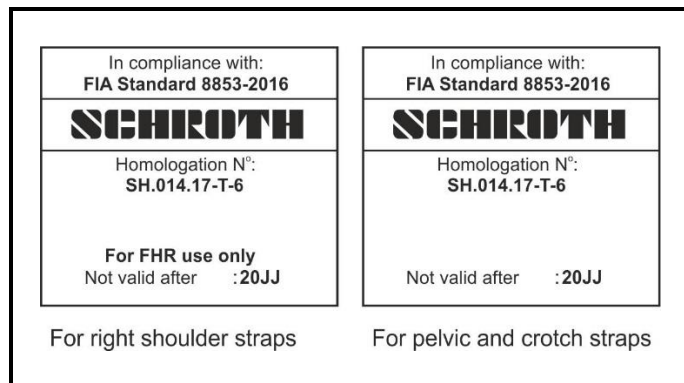

B1-3) Marquages pour boucle a libération complète
Full release buckle marking

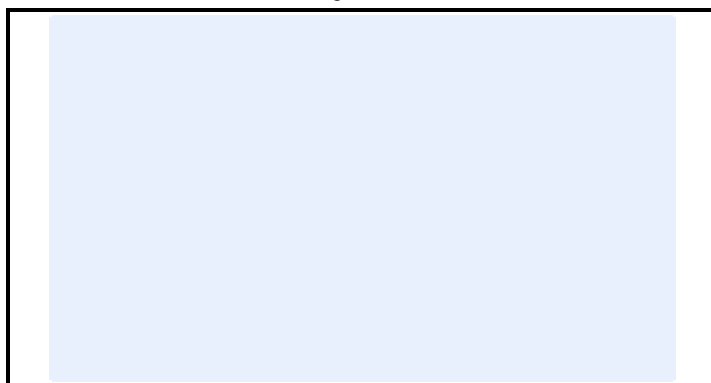

Marque
Make

SCHROTH SAFETY PRODUCTS
GMBH

Modèle
Model

SCHROTH T-BAR 2X2
(6-POINT HARNESS BELT WITH 2"
SHOULDER BELTS FOR FHR USE
ONLY AND WITH 2" PELVIC STRAPS)

SH.014.17-T-6

INFORMATIONS COMPLEMENTAIRES / COMPLEMENTARY INFORMATION

ALTERNATIVE ATTACHMENT – APPLICABLE ON ALL STRAPS (SHOULDER, PELVIC and CROTCH)

Wrap Around with 2-bar slide 	Sewn Loop 	B 64.20.xx sewn 	B 64.20.xx wrapped w. 3-bar slide 	B 50.xx.yy sewn 	B 24.xx.yy sewn 	B 24.xx.yy wrapped with 2-bar slide
Wrap Around with 3-bar slide 	B 154 sewn 	B 23 A sewn 	B 43 A sewn 	BK B 18.xx.yy sewn 	BK B 15 wrapped w. 2-bar slide 	BK B 15 wrapped w. 3-bar slide

ALTERNATIVE TONGUE – APPLICABLE SHOULDER STRAP

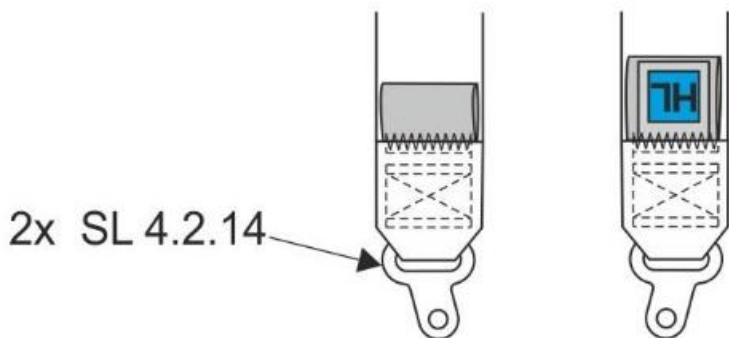

ALTERNATIVE TONGUE – APPLICABLE PELVIC STRAP

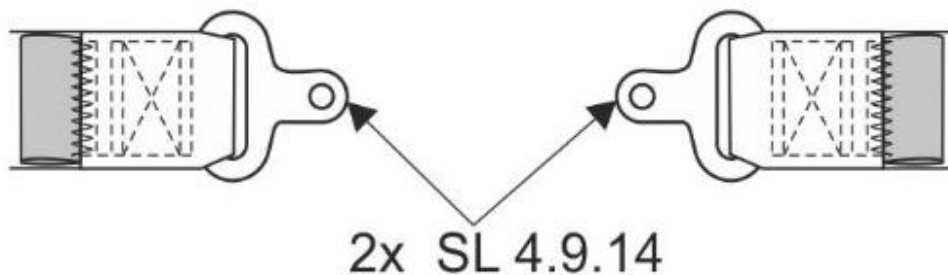

Marque **SCHROTH SAFETY PRODUCTS**
Make **GMBH**

Modèle
Model

SCHROTH T-BAR 2X2
(6-POINT HARNESS BELT WITH 2"
SHOULDER BELTS FOR FHR USE
ONLY AND WITH 2" PELVIC STRAPS)

SH.014.17-T-6

ALTERNATIVE TONGUE – APPLICABLE **PELVIC** STRAP

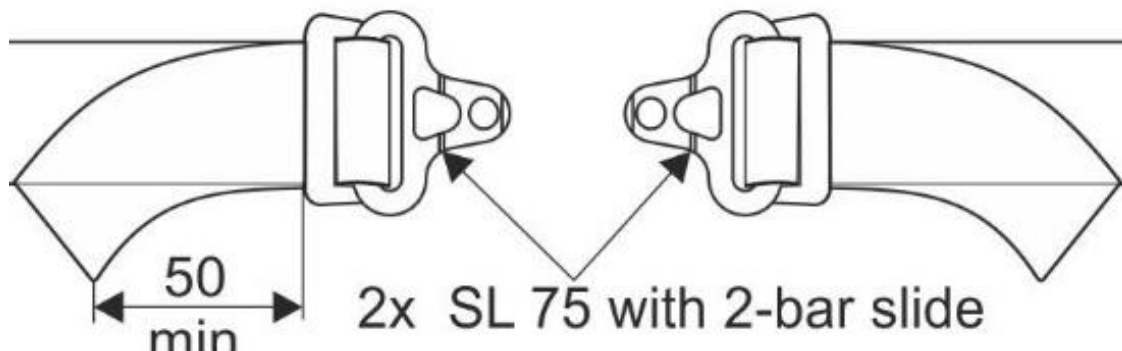

ALTERNATIVE ADJUSTER – APPLICABLE **SHOULDER** STRAP

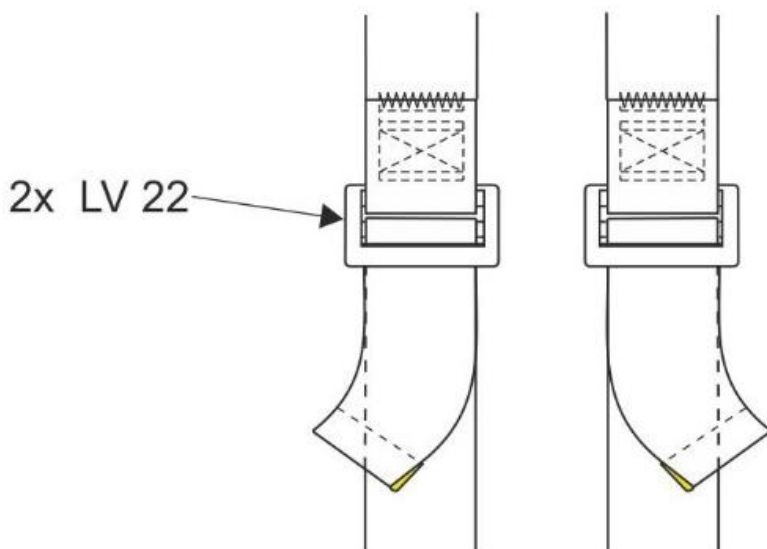

ALTERNATIVE ADJUSTER – APPLICABLE **PELVIC** STRAP (pull-up ad pull-down options)

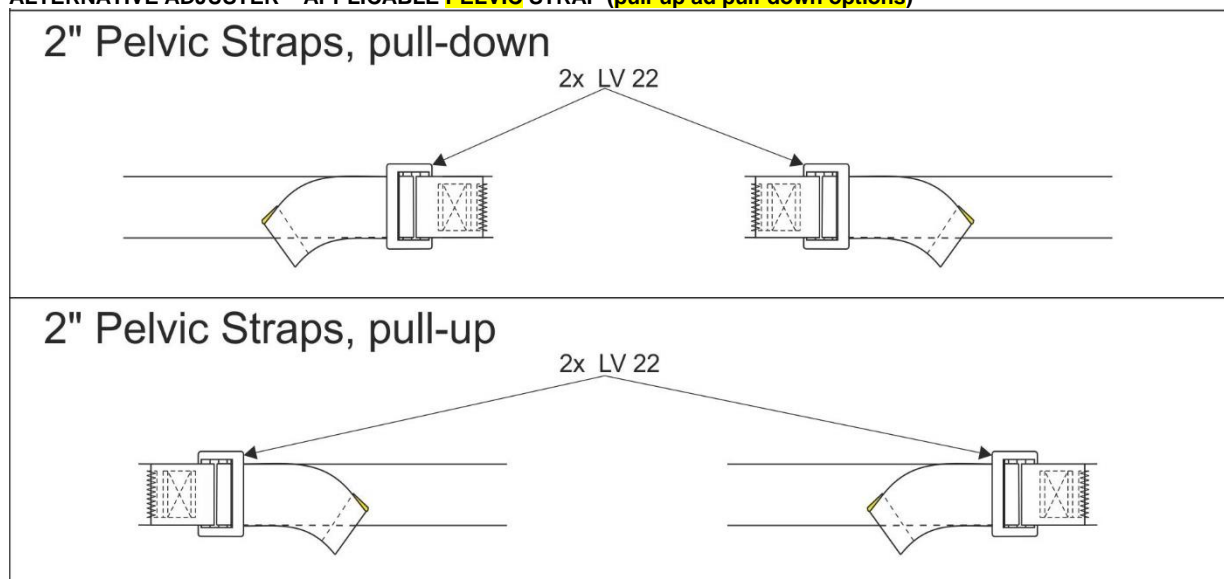

Marque
Make SCHROTH SAFETY PRODUCTS
GMBH

Modèle
Model

SCHROTH T-BAR 2X2
(6-POINT HARNESS BELT WITH 2"
SHOULDER BELTS FOR FHR USE
ONLY AND WITH 2" PELVIC STRAPS)

SH.014.17-T-6

ALTERNATIVE CROTCH STRAP WITHOUT ADJUSTER

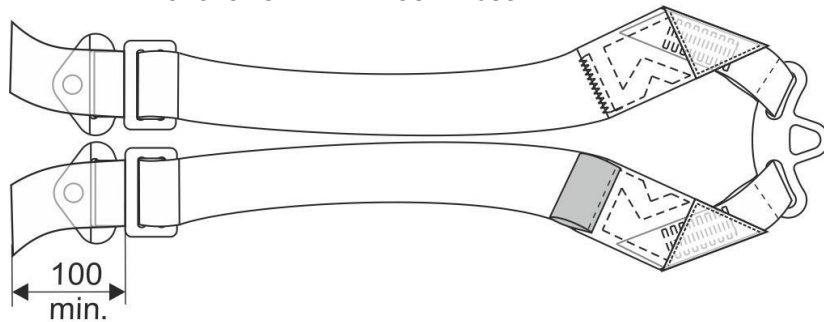

OPTIONAL PULL-TAB ON ADJUSTERS (with velcro)



ALTERNATIVE BUCKLE

BK SL 163.xx

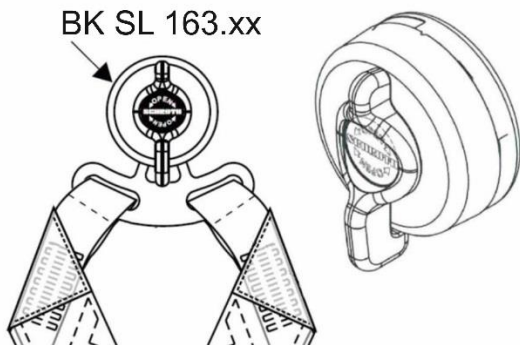

ALTERNATIVE STRUCTURAL SEAMS ON CROTCH STRAPS (N 135.184 and N 136.184)



Marque
Make SCHROTH SAFETY PRODUCTS
GMBH

Modèle
Model

SCHROTH T-BAR 2X2
(6-POINT HARNESS BELT WITH 2"
SHOULDER BELTS FOR FHR USE
ONLY AND WITH 2" PELVIC STRAPS)

SH.014.17-T-6

OPTIONAL YELLOW HAND LOOP AT SHOULDER STRAP (GU 10.013)



OPTIONAL 2" RUBBER FOAM ON PULL TABS (K 36.50)



OPTIONAL SCHROTH RACING LABEL ON 2" SHOULDER STRAP



Marque
Make

SCHROTH SAFETY PRODUCTS
GMBH

Modèle
Model

SCHROTH T-BAR 2X2
(6-POINT HARNESS BELT WITH 2"
SHOULDER BELTS FOR FHR USE
ONLY AND WITH 2" PELVIC STRAPS)

SH.014.17-T-6

OPTIONAL VELCRO PULL TABS ON SHOULDER ADJUSTER WITH WOVEN SCHROTH LOGO (W139)



OPTIONAL SEWN RELEASE STRAP (GU 10.001)



OPTIONAL WARNING LABEL PRINT ON SHOULDER BELT (K 149)



Marque
Make SCHROTH SAFETY PRODUCTS
GMBH

Modèle
Model

SCHROTH T-BAR 2X2
(6-POINT HARNESS BELT WITH 2"
SHOULDER BELTS FOR FHR USE
ONLY AND WITH 2" PELVIC STRAPS)

SH.014.17-T-6

OPTIONAL SMALL SCHROTH LOGO 47X10MM



OPTIONAL SMALL SCHROTH LOGO 70X10MM SEWN ON OPTIONAL SEWN PULL TAB



OPTIONAL RADIO/DRINK LOOP (GU 10.8.0)



Marque **SCHROTH SAFETY PRODUCTS**
 Make **GMBH**

Modèle
 Model

SCHROTH T-BAR 2X2
(6-POINT HARNESS BELT WITH 2"
SHOULDER BELTS FOR FHR USE
ONLY AND WITH 2" PELVIC STRAPS)

SH.014.17-T-6

OPTIONAL COUNTER GROUVE FARSIDE (K 86X20.0)



OPTIONAL VELCRO HOOK AND SOFT PART (K 31.1 AND K 31.2)



SERIAL NUMBER (BARCODE) STICKER PLACED ON THE HOMOLOGATION LABEL

FIA Label Information:
 additional Barcode with serial number
 on self-destructing label (sticker):
 length: 45 mm, height: 5 mm

