



# FEDERATION INTERNATIONALE DE L'AUTOMOBILE

Homologation N°

RN.024.21

Date

12.04.2021

## FICHE DE PRESENTATION DES FILETS DE COURSE (NORME FIA 8863-2013) PRESENTATION FORM FOR RACING NETS (FIA STANDARD 8863-2013)

### 1. GENERALITES / GENERAL

#### 101. CONSTRUCTEUR / MANUFACTURER

- \_\_\_\_\_
- a) Adresse  
Address Im Ohl 14, 59757 Arnsberg, Germany
- b) Téléphone  
Phone +49 2932 97 42 - 0
- c) E-mail  
E-mail germany@eu.schroth.com

#### 102. MODELE DU FILET DE COURSE / RACING NET MODEL

- a) Modèle  
Model SR INTERIOR NET KTM X-BOW RH
- b) Côté d'installation  
installation côté droit/right side

#### 103. PHOTO DU FILET DE COURSE COMPLET / PHOTO OF THE FULL RACING NET

- A1) Photo du filet de course avant l'installation  
Photo of the racing net before installation



## 2. DETAILS DU FILET DE COURSE / RACING NET DETAILS

### 201. FILET DE COURSE / RACING NET

a) Connexion à la voiture à l'avant <i>Front connection to the car</i>	Nombre / Number	Matériau / Material	Largeur / Epaisseur [mm] <i>Width / Thickness [mm]</i>
Sangles fixées à la voiture à l'avant <i>Straps fixed to the car at the front</i>	<b>upper vertical strap</b>	<b>polyester</b>	<b>24,3 / 1,6</b>
	<b>lower diagonal vertical strap</b>	<b>Polyester</b>	<b>24,3 / 1,6</b>
Type de fixation d'extrémité <i>Type of end fitting</i>	<b>wrap around with 3-bar slide</b>	<b>steel</b>	
Type de mécanisme de déverrouillage rapide <i>Type of quick release system</i>	<b>push button buckle see figure A2</b>	<b>metal and plastic components</b>	
b) Connexion à la voiture à l'arrière <i>Rear connection to the car</i>			
Sangles horizontales fixées à la voiture à l'arrière <i>Horizontal straps fixed to the car at the rear</i>	<b>3</b>	<b>Polyester</b>	<b>24,3 / 1,6</b>
Sangles verticales fixées à la voiture à l'arrière <i>Vertical straps fixed to the car at the rear</i>	<b>0</b>		
Type de fixation d'extrémité <i>Type of end fitting</i>	<b>wrap around with 3-bar slide</b>	<b>steel</b>	

A1) Filet de course - photo vue de dessus (avant l'installation)  
*Racing net – top view photo (before installation)*



A2) Mécanisme de déverrouillage rapide - photo 3/4 avant (avec indication du système d'ouverture)  
*Quick release system - 3/4 front photo (with opening system indicated)*



Marque  
Brand **SCHROTH**

Modèle  
Model

**SR INTERIOR NET KTM  
X-BOX RH**

Homologation N°

**RN.024.21**

A3) Attache avant - photo 3/4 avant (détail de l'enroulement)  
Front attachment - 3/4 front photo (details of strap routing)

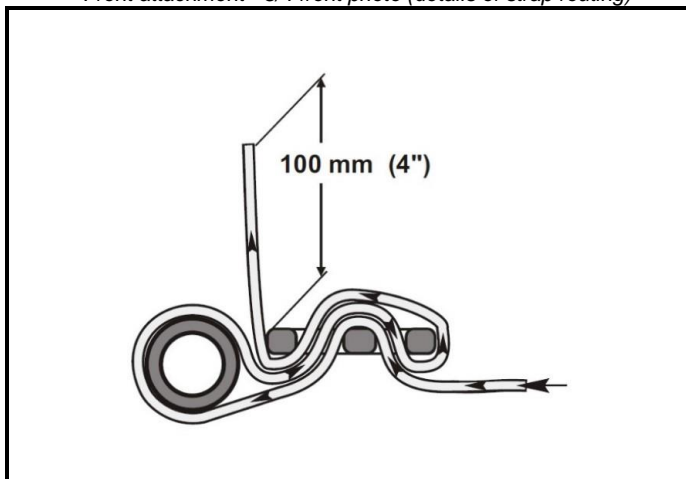

A4) Attaches arrière - photo 3/4 avant (détail de l'enroulement)  
Rear attachments - 3/4 front photo (details of strap routing)

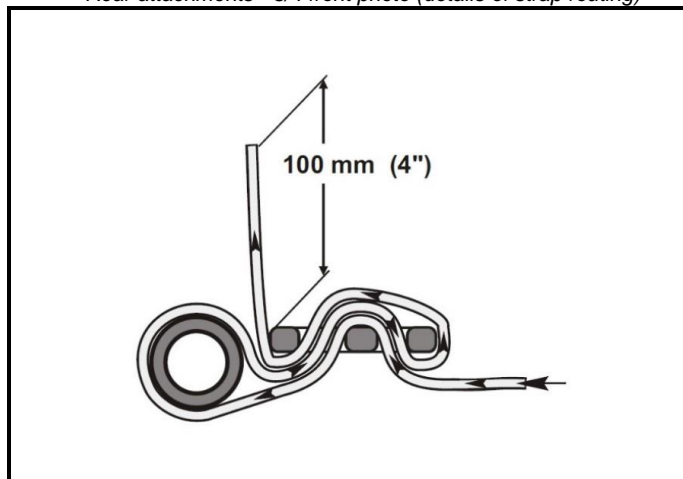

A5) Autre hardware - photo 3/4 avant  
Other hardware - 3/4 front photo (T-bar net tongue)



A6) Autre hardware - photo 3/4 avant  
Other hardware - 3/4 front photo (front strap tongue)



### 3. ETIQUETTE D'HOMOLOGATION / HOMOLOGATION LABEL

#### 301. ETIQUETTE / LABEL

Etiquette d'homologation  
Homologation label

a) Dimensions [mm]  
Dimensions [mm]

height 30 x width 80 (+ stitching areas)

Marque  
Brand **SCHROTH**

Modèle  
Model **SR INTERIOR NET KTM  
X-BOX RH**

Homologation N°

**RN.024.21**

B1) Etiquette d'homologation et autocollant FIA cousus sur le filet de course  
*Homologation label and FIA sticker stitched on the racing net*

In compliance with: <b>FIA Standard 8863-2013</b>	
Manufacturer Name:	<b>SCHROTH Safety Products GmbH</b> <small>Im Ohl 14 • 59757 Arnsberg • Germany</small>
Serial N°:	<b>BARCODE: EAN Code 39</b> <b>CFyyzzzzz</b>
Homologation N° :	<b>RN.024.21</b>
Model :	<b>SR Interior Net KTM X-Bow RH</b>
Not valid after :	<b>20JJ</b>

Marque  
Brand **SCHROTH**

Modèle  
Model **SR INTERIOR NET KTM  
X-BOX RH**

Homologation N°

**RN.024.21**

**INFORMATIONS COMPLEMENTAIRES / COMPLEMENTARY INFORMATION**

**FIA Label Information:**  
additional Barcode with serial number  
on self-destructing label (sticker):  
length: 45 mm, height: 5 mm

