



FEDERATION INTERNATIONALE DE L'AUTOMOBILE

Homologation N°

RN.016.19

Date

26.11.2019

FICHE DE PRESENTATION DES FILETS DE COURSE (NORME FIA 8863-2013) PRESENTATION FORM FOR RACING NETS (FIA STANDARD 8863-2013)

1. GENERALITES / GENERAL

101. CONSTRUCTEUR / MANUFACTURER

SCHROTH SAFETY PRODUCTS GMBH

- a) Adresse
Address **Im Ohl 14, 59757 Arnsberg, Germany**
- b) Téléphone
Phone **+49 2932 97 42 - 0**
- c) E-mail
E-mail **germany@eu.schroth.com**

102. MODELE DU FILET DE COURSE / RACING NET MODEL

- a) Modèle
Model **SR INTERIOR NET DT I**
- b) Côté d'installation
Installation **valid for both sides**

103. PHOTO DU FILET DE COURSE COMPLET / PHOTO OF THE FULL RACING NET

- A1) Photo du filet de course avant l'installation
Photo of the racing net before installation

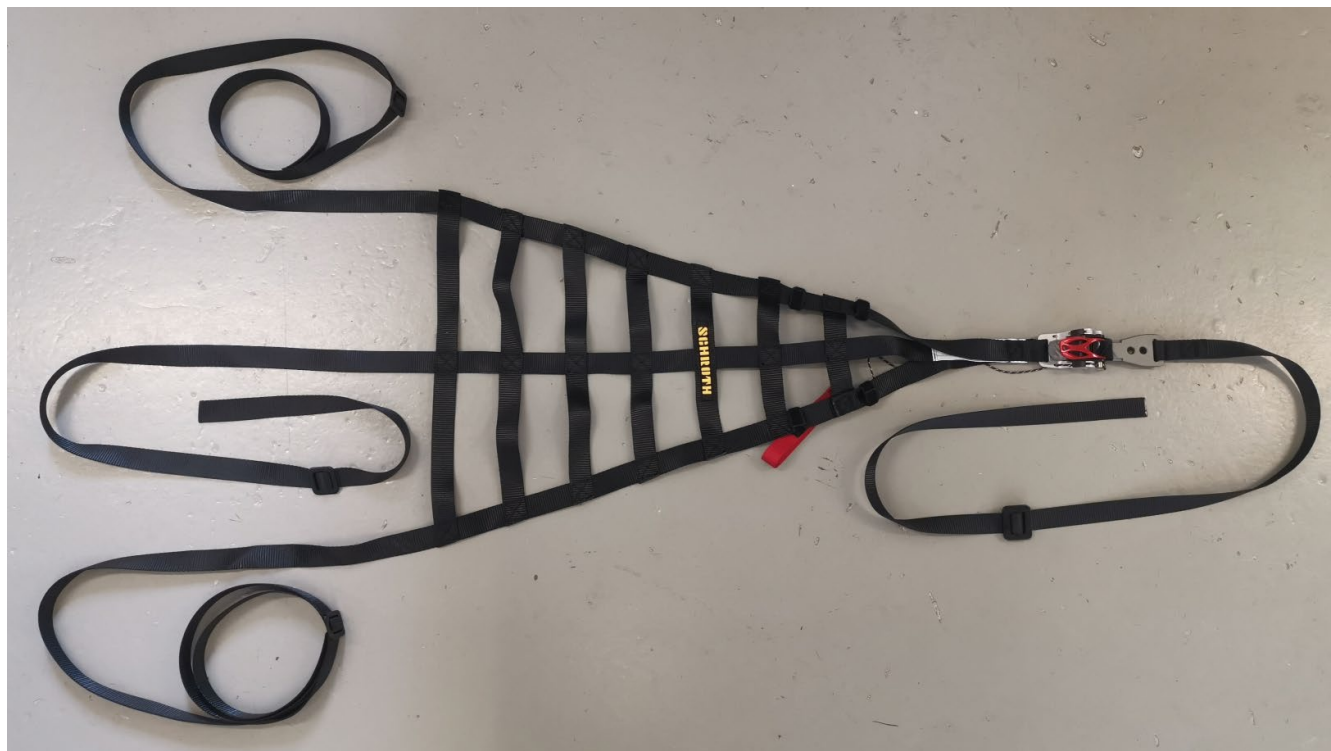

2. DETAILS DU FILET DE COURSE / RACING NET DETAILS

201. FILET DE COURSE / RACING NET

a) Connexion à la voiture à l'avant <i>Front connection to the car</i>	Nombre / Number	Matériau / Material	Largeur / Epaisseur [mm] Width / Thickness [mm]
Sangles fixées à la voiture à l'avant <i>Straps fixed to the car at the front</i>	1 (C) - see figure A1	Polyester	25 / 1,6
Type de fixation d'extrémité <i>Type of end fitting</i>	wrap around with 3-bar slide (E1)	steel	
Type de mécanisme de déverrouillage rapide <i>Type of quick release system</i>	ratchet	metal and plastic components	
b) Connexion à la voiture à l'arrière <i>Rear connection to the car</i>			
Sangles horizontales fixées à la voiture à l'arrière <i>Horizontal straps fixed to the car at the rear</i>	3 (D1, D2, D3) - see figure A1	Polyester	26,5 / 1,7
Sangles verticales fixées à la voiture à l'arrière <i>Vertical straps fixed to the car at the rear</i>	0		
Type de fixation d'extrémité <i>Type of end fitting</i>	wrap around with 3-bar slide (E2, E3, E4)	steel	

A1) Filet de course - photo vue de dessus (avant l'installation)
Racing net – top view photo (before installation)

A2) Mécanisme de déverrouillage rapide - photo 3/4 avant (avec indication du système d'ouverture)
Quick release system - 3/4 front photo (with opening system indicated)

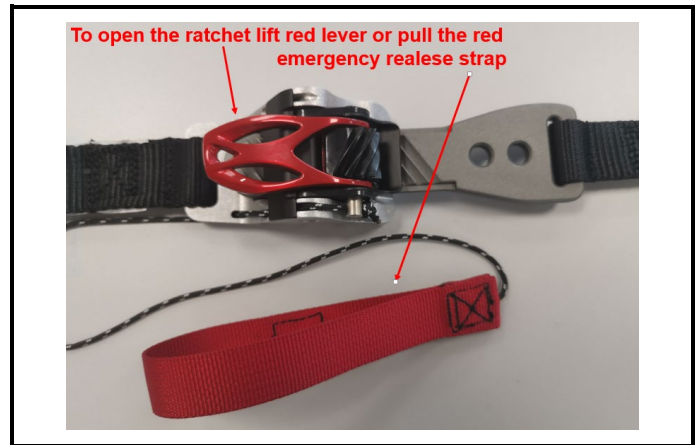
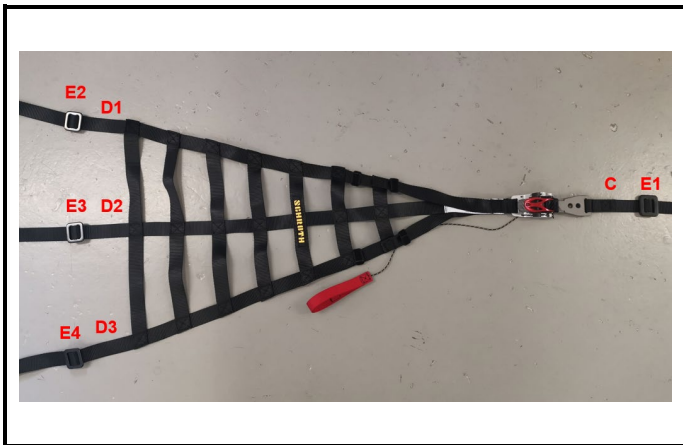

A3) Attache avant - photo 3/4 avant (détail de l'enroulement)
Front attachment - 3/4 front photo (details of strap routing)

A4) Attaches arrière - photo 3/4 avant (détail de l'enroulement)
Rear attachments - 3/4 front photo (details of strap routing)

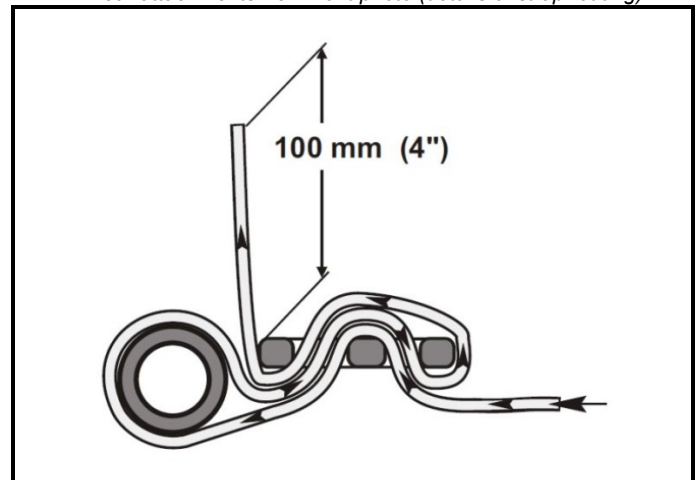
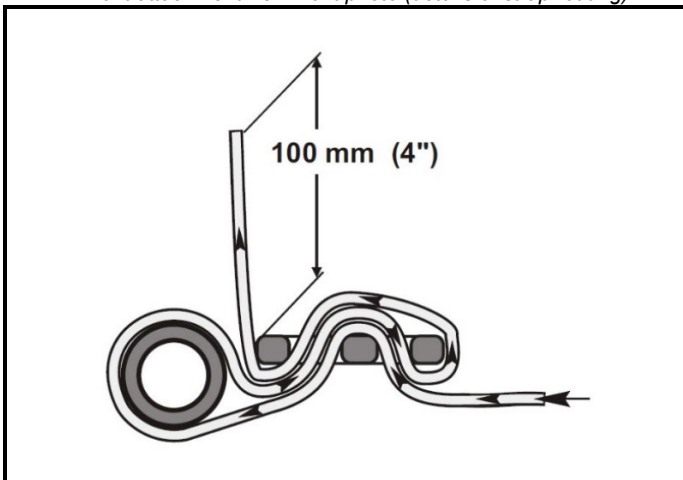

Marque
Brand **SCHROTH**

Modèle
Model

SR INTERIOR NET DT I

Homologation N°

RN.016.19

A5) Autre hardware - photo 3/4 avant
Other hardware - 3/4 front photo (E1)



A6) Autre hardware - photo 3/4 avant
Other hardware - 3/4 front photo (E2, E3, E4)



3. ETIQUETTE D'HOMOLOGATION / HOMOLOGATION LABEL

301. ETIQUETTE / LABEL

Etiquette d'homologation
Homologation label

a) Dimensions [mm]
Dimensions [mm]

height 30 x width 80 (+ stitching areas)

B1) Etiquette d'homologation et autocollant FIA cousus sur le filet de course
Homologation label and FIA sticker stitched on the racing net

In compliance with: FIA Standard 8863-2013	
Manufacturer Name:	SCHROTH Safety Products GmbH Im Ohl 14 • 59757 Arnsberg • Germany
Serial N°:	
Homologation N° :	RN.016.19
Model :	SR Interior Net DT I
Not valid after :	20JJ

Marque
Brand **SCHROTH**

Modèle
Model **SR INTERIOR NET DT I**

Homologation N°

RN.016.19

INFORMATIONS COMPLEMENTAIRES / COMPLEMENTARY INFORMATION

