



FEDERATION INTERNATIONALE
DE L'AUTOMOBILE

Homologation N°

RN.004.16

Date

15.06.2016

FICHE DE PRESENTATION DES FILETS DE COURSE (NORME FIA 8863-2013)
PRESENTATION FORM FOR RACING NETS (FIA STANDARD 8863-2013)

1. GENERALITES / GENERAL

101. CONSTRUCTEUR / MANUFACTURER

SCHROTH SAFETY PRODUCTS GMBH

- a) Adresse
Address **Im Ohl 14, 59757 Arnsberg, GERMANY**
- b) Téléphone
Phone **+49 2932 97 42 - 0**
- c) E-mail
E-mail **germany@schroth.com**

102. MODELE DU FILET DE COURSE / RACING NET MODEL

- a) Modèle
Model **SR INTERIOR NET I - LA**
- b) Côté d'installation
Installation **valid for both sides**

103. PHOTO DU FILET DE COURSE COMPLET / PHOTO OF THE FULL RACING NET

- A1) Photo du filet de course avant l'installation
Photo of the racing net before installation

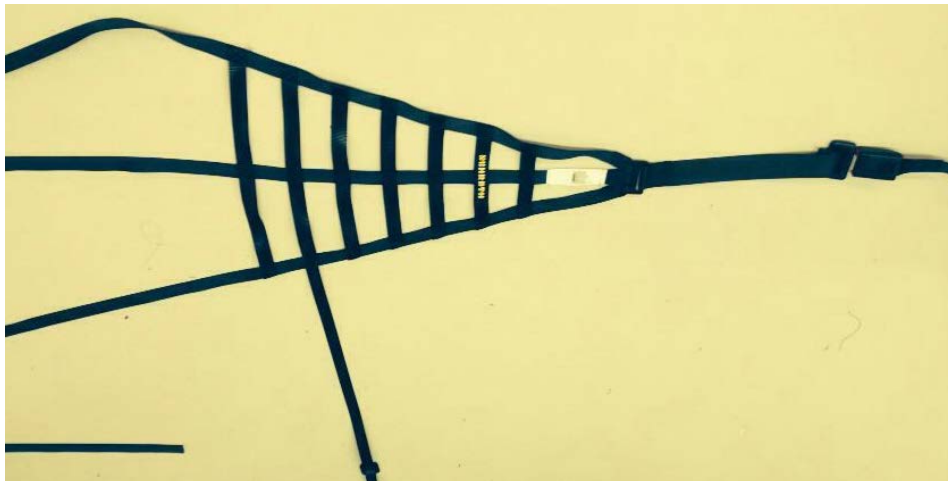

2. DETAILS DU FILET DE COURSE / RACING NET DETAILS

201. FILET DE COURSE / RACING NET

a) Connexion à la voiture à l'avant <i>Front connection to the car</i>	Nombre / Number	Matériau / Material	Largeur / Epaisseur [mm] Width / Thickness [mm]
Sangles fixées à la voiture à l'avant <i>Straps fixed to the car at the front</i>	1 (C) - see figure A1	Polyester	26,5 / 1,7
Type de fixation d'extrémité <i>Type of end fitting</i>	wrap around with 3-bar slide (E1)	steel	
Type de mécanisme de déverrouillage rapide <i>Type of quick release system</i>	Push Button Buckle + Adjusting Latch	Metal components (Steel) / plastic covers	
b) Connexion à la voiture à l'arrière <i>Rear connection to the car</i>			
Sangles horizontales fixées à la voiture à l'arrière <i>Horizontal straps fixed to the car at the rear</i>	3 (D1, D2, D3) -see figure A1	Polyester	26,5 / 1,7
Sangles verticales fixées à la voiture à l'arrière <i>Vertical straps fixed to the car at the rear</i>	1 (F1) optional strap for lower door bar	Polyester	
Type de fixation d'extrémité <i>Type of end fitting</i>	wrap around with 3-bar slide (E2, E3, E4, E5)	steel	

A1) Filet de course - photo vue de dessus (avant l'installation)
Racing net – top view photo (before installation)

A2) Mécanisme de déverrouillage rapide - photo 3/4 avant (avec indication du système d'ouverture)
Quick release system - 3/4 front photo (with opening system indicated)

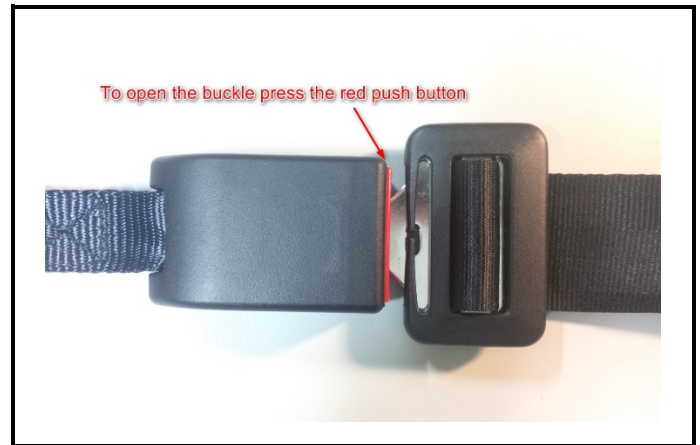
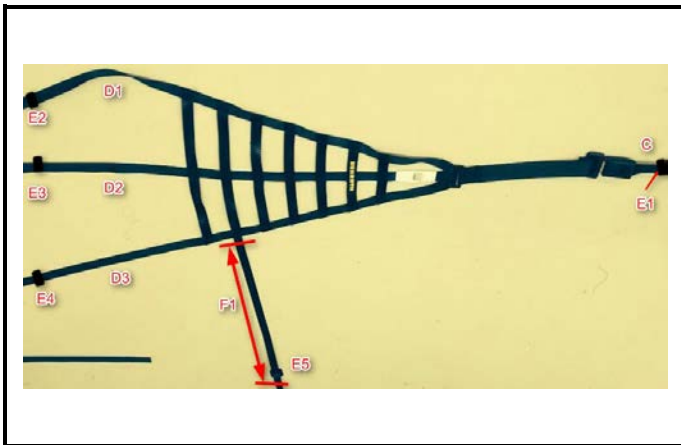

A3) Attache avant - photo 3/4 avant (détail de l'enroulement)
Front attachment - 3/4 front photo (details of strap routing)

A4) Attaches arrière - photo 3/4 avant (détail de l'enroulement)
Rear attachments - 3/4 front photo (details of strap routing)

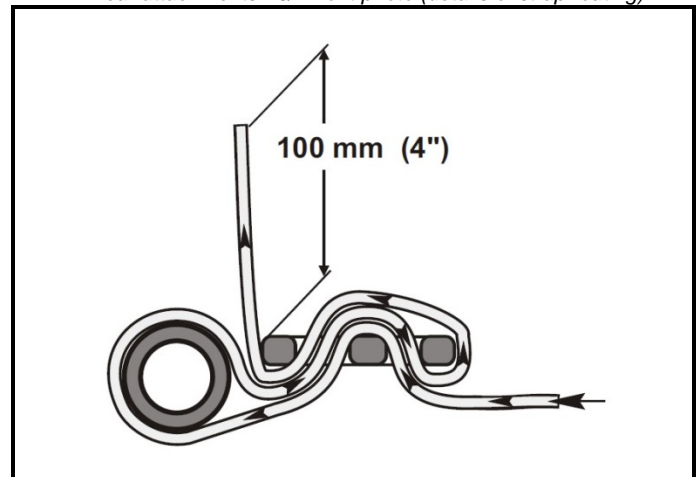
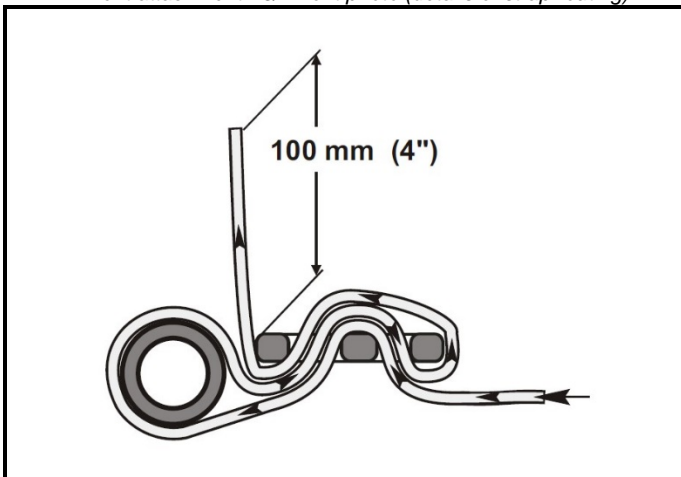

Marque
Brand

**SCHROTH Safety Products
GmbH**

Modèle
Model

SR Interior Net I - LA

Homologation N°

RN.004.16

A5) Autre hardware - photo 3/4 avant
Other hardware - 3/4 front photo ()



A6) Autre hardware - photo 3/4 avant
Other hardware - 3/4 front photo ()

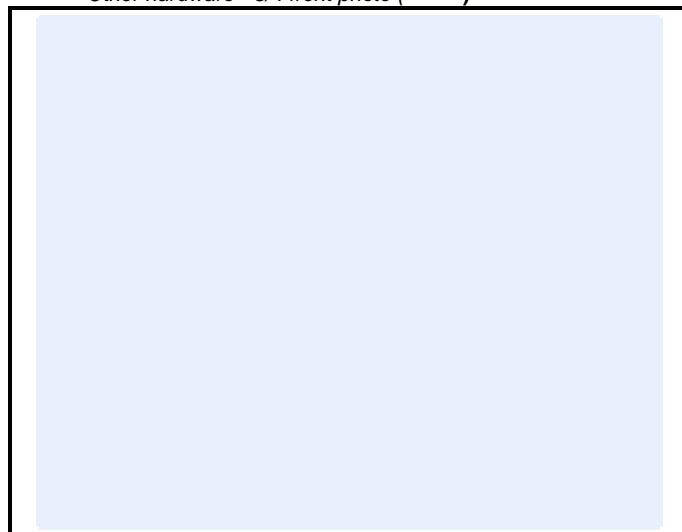

3. ETIQUETTE D'HOMOLOGATION / HOMOLOGATION LABEL

301. ETIQUETTE / LABEL

Etiquette d'homologation
Homologation label

a) Dimensions [mm]
Dimensions [mm]

80 (total length 105) x 30

B1) Etiquette d'homologation et autocollant FIA cousus sur le filet de course
Homologation label and FIA sticker stitched on the racing net



INFORMATIONS COMPLÉMENTAIRES / COMPLEMENTARY INFORMATION

