



FEDERATION INTERNATIONALE DE L'AUTOMOBILE

**RACING NETS INSTALLATION SPECIFICATION FOR TOURING AND GRAND
TOURING CARS**

04-10-2019 v7

FOREWORD

Racing Nets are designed to provide lateral restraint to the SEAT and DRIVER during lateral and angled lateral impacts.

The aim of this specification is to provide objective installation requirements of FIA-approved 8863 racing nets (see Technical List n°48) in association with FIA-approved 8862 and 8855 seats with either fixed or sliding brackets. This specification defines requirements on the positioning of the racing net, its attachment to the car and a load case for the attachment points.

1. Load case for attachment points

1.1 Single-Front-Attachment

The front-straps of each Racing Net shall have a single attachment to the car. The attachment shall be designed to sustain 10kN MIN with 15mm MAX deformation.

Each rear-strap of the Racing Net shall attach to the car at a separate position. The attachments shall be designed to sustain 10kN MIN with 15mm MAX deformation.

1.2 Dual-front-Attachment

The forward and upper front-straps of each Racing Net shall each have a single attachment to the car. The attachment shall be designed to sustain 10kN MIN with 15mm MAX deformation.

Each rear-strap of the Racing Net shall attach to the car at a separate position. The attachments shall be designed to sustain 10kN MIN with 15mm MAX deformation.

2. Fitment of handed nets

Nets are typically handed; left or right. The net horizontal webbing shall be located towards the driver, to provide the smoothest surface for the helmet to glide on, with the net vertical webbing located away from the driver.

3. Positioning main triangle of the racing net

In order to ensure optimal protection, it is imperative that the driver is, first, correctly fitted to the FIA-approved 8862 or 8855 seat as defined in Appendix A of this document.

Once this has been achieved, the FIA-approved 8863 Racing Net shall be installed as detailed below; with the upper strap positioned relative to driver's eye position (with additional limits in Z relative to the seat-side-head) and the lower-strap positioned relative to the seat-side-shoulder.

- It is recommended that, where possible, the upper-strap of the racing net is positioned *inside* the seat-side-head as shown in Figure 1 (see also Figures 3 and 4).
- Where the above position cannot be achieved, for instance, if the seat-side-head and seat-side-shoulder of the seat are integrated, the upper-strap may be positioned *outside* the seat-side-head as shown in Figure 2.

When viewed from the side;

3.1 - the upper-strap¹ shall pass through the eye position +80mm(Z)-15mm(Z) and shall be angled at 10° +5° relative to the horizontal plane. Additionally, the upper-strap¹ shall not run more than 40mm above the top edge of the seat-side-head. And the upper-strap² shall not run below the bottom edge of the seat-side-head.

3.2 - the middle-strap shall be horizontal ± 10° relative to the horizontal plane.

3.3 - the lower-strap³ shall run along the bottom edge of the seat-side-shoulder +0(Z)-100(Z) and shall be angled at 15° +10° relative to the horizontal plane.

3.4 - the merge point will, typically, be 500-700mm forward of the driver's eye position.

3.5 - the net shall have a minimum of two vertical webbings in contact with the seat-side-head.

3.6 - the eye position of all drivers shall be marked on the external side of the seat-side-head support.

Dual-front-attachment only (see Figure 5).

3.7 When viewed from the side, the forward strap shall be horizontal +0 – [30]deg

3.8 When viewed from the side, the upper strap shall be vertical +45deg (forward) - 20deg.

¹ measured from top edge of upper-strap

² measured from bottom edge of upper-strap

³ measured from bottom edge of lower-strap

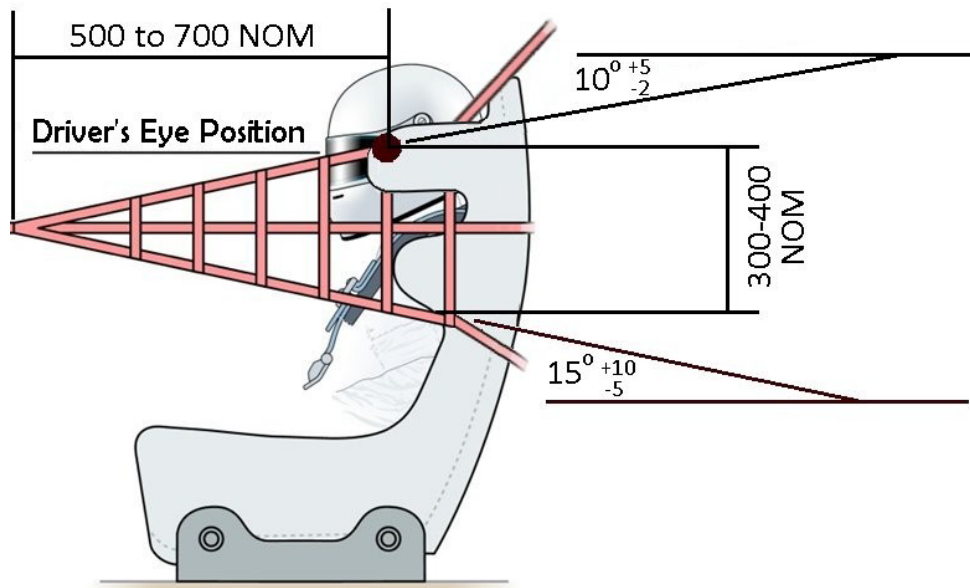

Figure 1: Positioning of net with upper-strap *inside* the seat-side-head
(applicable to both Single-front-attachment design and to Dual-front-attachment design)

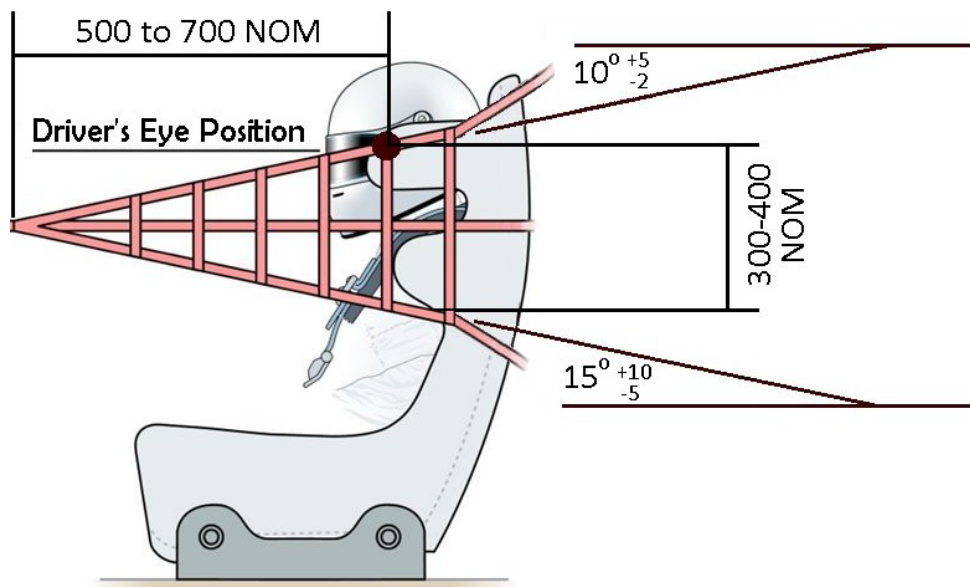

Figure 2: Positioning of net with upper-strap *outside* the seat-side-head
(applicable to both Single-front-attachment design and to Dual-front-attachment design)

Note: NOM dimensions for guidance only



Figure 3: Photograph showing upper-strap inside the seat-side-head, shown with single-front-attachment design (external view, but valid also for Dual-front-attachment)



Figure 4: Photograph showing upper-strap inside the seat-side-head, shown with single-front-attachment design (internal view, but valid also for Dual-front-attachment)

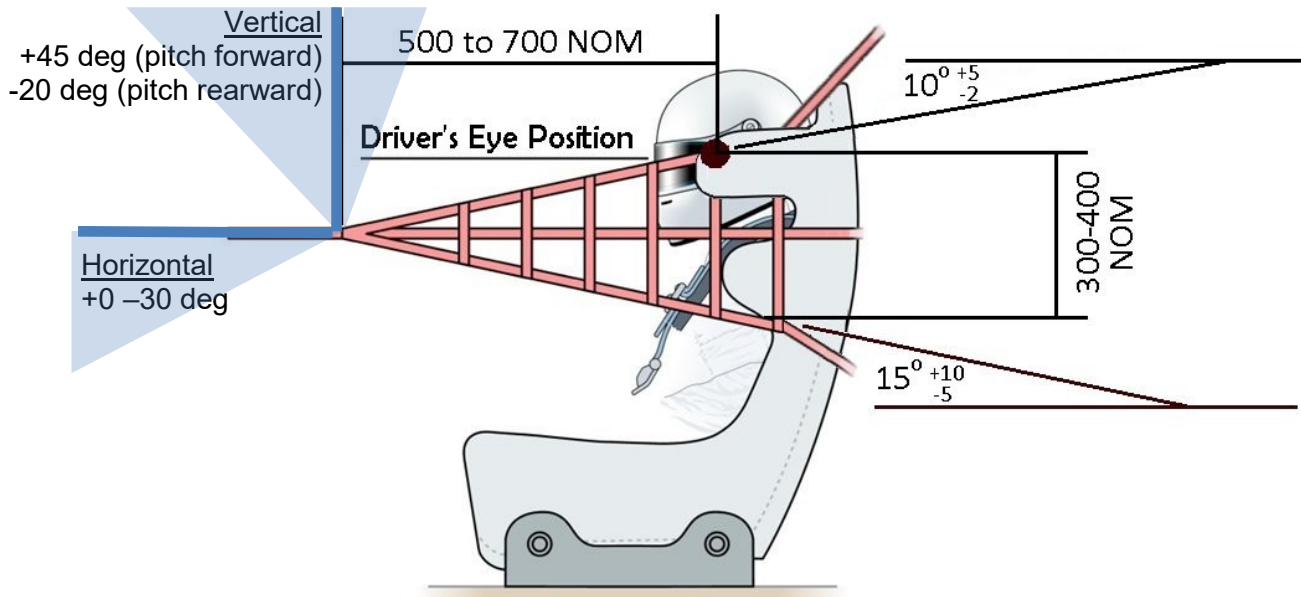

Figure 5. Positioning of net with Dual-front-attachment design

4. Attaching the front and rear straps of the racing net

When viewed from above;

4.1 - the front straps shall be parallel to the longitudinal axis of the car $\pm 6^\circ$ as shown in Figure 6.

4.2 - the rear-middle-strap and rear-lower-strap shall wrap the seat and attach to rollcage (or chassis) at an angle parallel to the lateral axis of the car within range $[+20^\circ; -30^\circ]$ as shown in Figure 6, in order to maximise the lateral restraint of the seat and driver.

4.3 - if the upper-strap is positioned inside the seat-side-head (as shown in Figure 1), the rear- upper-strap shall attach directly to the main hoop or roof tube. The attachment point shall be carefully chosen to maximise lateral restraint and vertical control of the net whilst ensuring it does not interfere with the helmet (during normal race conditions).

4.4 - if the upper-strap is positioned outside the seat-side-head (as shown in Figure 2), the rear- upper-strap shall wrap the seat and attach to rollcage (or chassis) at an angle parallel to the lateral axis of the car within range $[+20^\circ; -30^\circ]$ as shown in Figure 6, in order to maximise the lateral restraint of the seat and driver.

Exceptionally, the rear-upper-strap may attach directly to the main hoop or roof tube, without having to satisfy the $+20^\circ -30^\circ$ angle prescribed in Figure 6, if either of the following two conditions is encountered:

- the upper-strap would otherwise run above the top edge of the seat and would interfere with the helmet (during normal race conditions)
- doing so provides a better vertical load proportioning with the rear-lower-strap and prevents the racing-net from slipping down on the seat

In such cases, the attachment point shall be carefully chosen to maximise lateral restraint and vertical control of the net.

4.5 - it is preferable that all three rear straps attach to rollcage joints rather than mid-tube. Any mid-tube attachment should be fitted with a clamp or similar restraint to prevent sliding along the tube.

4.6 - the rear-middle strap may be attached to the middle of main hoop if this achieves the best geometrical installation.

4.7 - the rear-upper strap shall attach close to the roof.

4.8 - the rear-lower strap shall attach close to the floor.

4.9 - the tension in the racing-net shall be such that, at any x-position of each upper, middle and lower strap of the triangle, a load of 50N applied in a lateral direction away from the driver shall produce a maximum deformation of 50mm.

4.10 - in order to minimise any potential interference between the front-strap and the driver's arms or hands, a bungee may be fitted to pre-tension the net away from the driver. Such an installation should not impede the driver's egress when the quick-release of the net is disconnected. Furthermore, the requirements of 4.9 shall be satisfied before the bungee is fitted.

4.11 - if the side profile of the seat is such that the lower-strap is able to slide upwards above the bottom edge of the seat-side-shoulder, an additional vertical strap may be wrapped around the lower-strap, close to the seat-side-shoulder and secured to an appropriate attachment point below it.

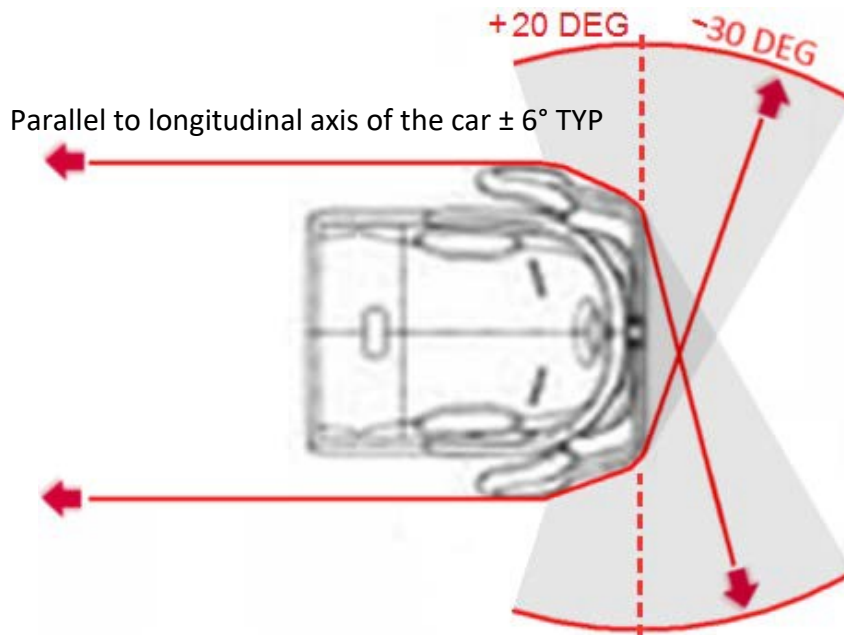

Figure 6: Attachment of front and rear straps

5. Concessions

NOTES:

- ~~Article 5 will not be is not applicable for new cars homologated as from 1.1.2017.~~
- ~~Article 5 will not be applicable for any cars as from 1.1.2019 ITBC1.~~
- ~~Article 5.1.2 will not be applicable for any cars as from 1.1.2021.~~
- ~~Article 5.1.3 and 5.1.4 will not be applicable for any cars as from 1.1.2020.~~

5.1. General

5.1.1 - The seat may be modified to provide location points for the straps (bonded only), upon approval from FIA.

5.1.2 - If the angle of the upper-strap prescribed in section 3.1 cannot be achieved, the front strap attachment must be chosen to satisfy, as close as possible, this requirement (3.1). The other requirements of section 3.1 shall be satisfied.

5.1.3 - If the racing net installation cannot meet the tension criterion prescribed in section 4.9, primarily due to backlash in the quick-release, the net should be configured such that it is as tight as possible when the quick release is connected, and the maximum deformation under the 50N lateral load must not be greater than 80mm.

5.1.4 For cars unable to satisfy the load case for attachment points prescribed in section 1, the attachments may be designed to sustain 6kN MIN with 15mm MAX deformation.

5.2. Sliding seats

When sliding seats are used, the racing net installation specification must be respected. However, in order to ensure compatibility, each of the rear-upper-strap, rear-middle-strap and rear-lower-strap may attach to the rollcage (or chassis) at a minimum angle of 10° parallel to the longitudinal axis of the car as shown in [Figure 7](#).

If there is no appropriate attachment point for the rear-middle-strap or the rear-lower-strap, either of them shall be positioned as close as possible to this above requirement. In any case, the racing net shall be in contact with the seat.

The attachment points shall be carefully chosen to maximise lateral restraint and vertical control of the net.

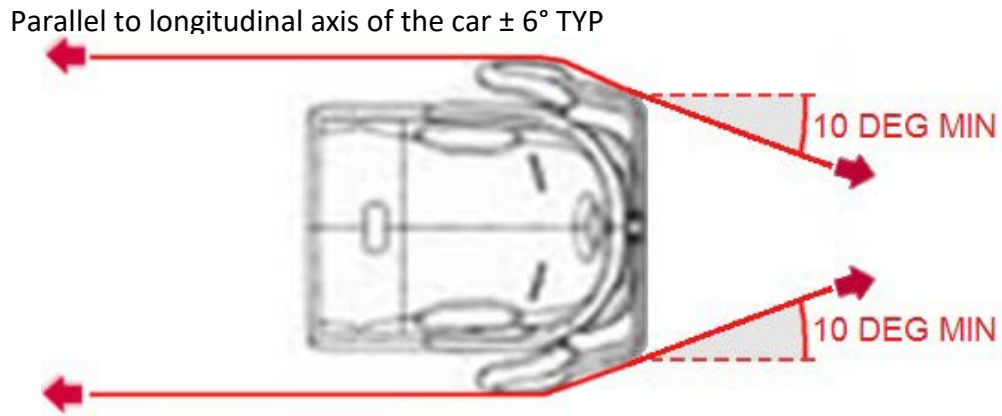

Figure 7: Attachment of front and rear straps

APPENDIX A

FIA REQUIREMENTS FOR DRIVER FITMENT IN AN FIA-APPROVED [8862-2009](#) SEAT

A1. - The driver shall choose a seat that fits well. When seated in the normal racing position, the seat shall support comfortably at the pelvis, shoulder and head as follows:

- the eye line shall be below the top edge of the side head support and above the bottom edge of the side head support;
- the shoulder should fit within the side shoulder support of the seat;
- the pelvis should be adequately supported by the side pelvis support.

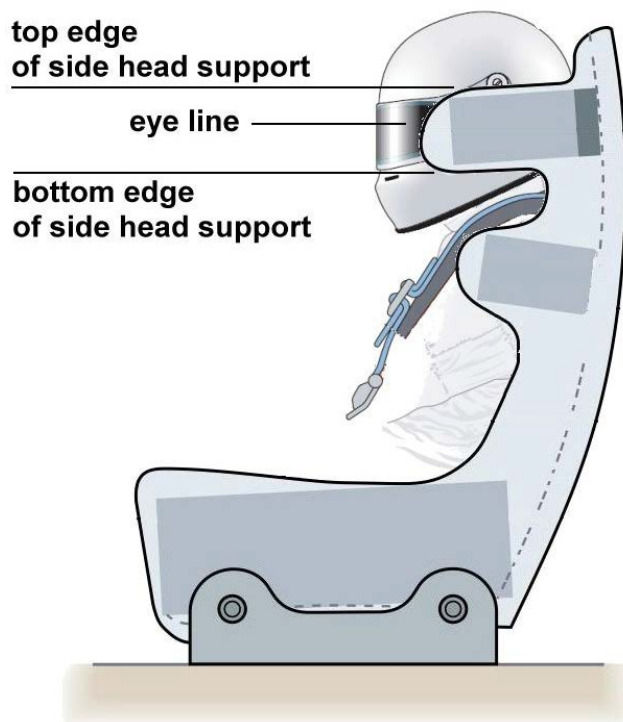

Figure A1 - Position of drivers head relative to side head support

LIST OF AMENDMENTS

New text: **thus**
 Deleted text: ~~thus~~
 Comments: *thus*

Date	Modifications
02.12.2015	<i>Initial release</i>
24.06.2016	<p>5. Concessions</p> <ul style="list-style-type: none"> • <u>Article 5 will not be applicable for new cars homologated as from 1.1.2017.</u> • <u>Article 5 will not be applicable for any cars as from 1.1.2019 ITBC1.</u> (...)
10.10.2019	<p>1. Load case for attachment points</p> <p><u>1.1 Single-Front-Attachment</u> The front-straps of each Racing Net shall have a single attachment to the car. The attachment shall be designed to sustain 10kN MIN with 15mm MAX deformation.</p> <p>Each rear-strap of the Racing Net shall attach to the car at a separate position. The attachments shall be designed to sustain 10kN MIN with 15mm MAX deformation.</p> <p><u>1.2 Dual-front-Attachment</u> <u>The forward and upper front-straps of each Racing Net shall each have a single attachment to the car. The attachment shall be designed to sustain 10kN MIN with 15mm MAX deformation.</u></p> <p><u>Each rear-strap of the Racing Net shall attach to the car at a separate position. The attachments shall be designed to sustain 10kN MIN with 15mm MAX deformation.</u></p>
10.10.2019	<p><u>Dual-front-attachment only (see Figure 5).</u></p> <p><u>3.9 When viewed from the side, the forward strap shall be horizontal +0 – [30]deg</u></p> <p><u>3.10 When viewed from the side, the upper strap shall be vertical +45deg (forward) - 20deg</u></p>
10.10.2019	<p>5. Concessions</p> <ul style="list-style-type: none"> • <u>Article 5 will not be is not applicable for new cars homologated as from 1.1.2017.</u> • Article 5 will not be applicable for any cars as from 1.1.2019 ITBC1. • <u>Article 5.1.2 will not be applicable for any cars as from 1.1.2021.</u> • <u>Article 5.1.3 and 5.1.4 will not be applicable for any cars as from 1.1.2020.</u>