



Technical Bulletin 040 – Plumbed-in FIA Technical List 16 Systems – Installation Guide

Homologation Numbers EX.042.17, EX.043.17, EX.044.17, EX.064.21, EX.065.21
Rev3 03/03/2025

Lifeline Fire and Safety Systems can provide an extinguisher, plumbed-in or handheld, using foam, powder or clean agent suppressants to suit all motorsport series. The information below provides a guide to installing your chosen system.

Any motorsport onboard fire suppression system is designed to delay the development of the fire and give the occupants more time to exit the vehicle. These systems are not designed to save the vehicle.

Unfortunately, due to the variety of vehicles being raced the exact location of the components of the systems cannot be defined by Lifeline; this document provides “best practise” advice suitable for most vehicles. If you feel that your installation cannot follow these guidelines, please contact Lifeline Technical for further guidance.

Fully read and understand the instructions below before starting installation. Plan your installation carefully referring to the tables below and the system drawing. Do not cut the supplied tubing, over-braid or the plug and lead sets of an electric system until you are certain of the location of the cylinder, connectors, nozzles, switches or pull cables and power pack.

Other References (available at www.lifeline-fire.co.uk)

TB001	System Care, Maintenance and Service
TB003	FK 5-1-12 MSDS
TB063	ABF Foam MSDS
TB009	Extinguisher Selection
TB041	FIA TL 16 Systems – Kit Content and Spares
TB042	FIA TL 16 – Data Sheet

Section 1 – Cylinder, Bracket and Straps – All Systems

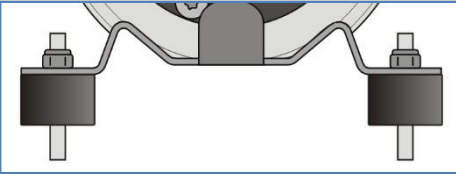
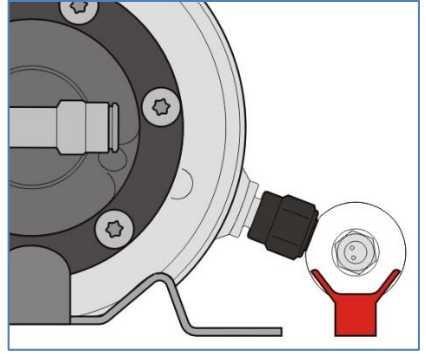
Item and System Type	Fixing Type and No.	Location and Fitting Guide
<p>Cylinder and Bracket – All Stored Pressure Systems</p>	<p>4xM6 nut, bolt and washers. Anti-vibration washers and/or Nylocs are highly recommended. AV mounts may be required to protect the cylinder in some cars where vibration is a known problem.</p>  <p>Figure 1 - AV Mount Fixing</p> <p>The use of self-tapping screws or inserts is not permitted. Correctly specified and fitted automotive chassis inserts are acceptable</p>	<p>Mount bracket transversally within the roll cage or safety cell. Ref FIA Appendix J Art 253 7.2</p> <p>Avoid positions where cylinder is likely to be knocked or be exposed to excess heat.</p> <p>Mark hole position through first bracket and refer to table below for position of 2nd bracket</p>
<p>Cylinder and Bracket – CD Remote Systems</p>	<p>As above plus 2x saddle brackets for remote charge</p>	<p>Next to cylinder and cylinder bracket.</p>  <p>Figure 2 - Saddle Mount Position</p>
<p>T-Bolt Straps</p>	<p>2x T-Bolt straps</p>	<p>Thread through provided slots in brackets and around the cylinder. Tighten T-bolts using spanner being careful not to damage the cylinder</p>

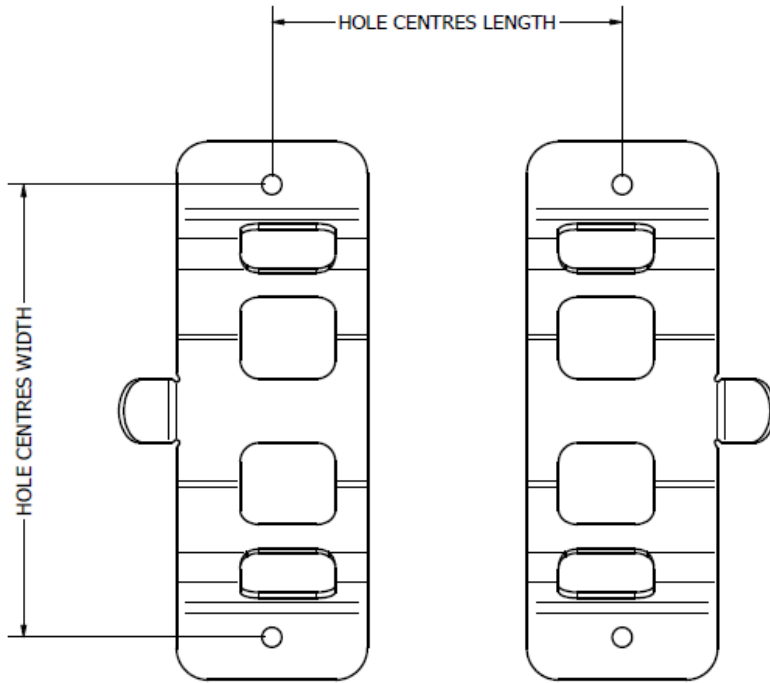

Figure 3 - Fixing Centres

LENGTH	
CD Remote Systems	CTRS (mm)
Zero 360 3.0kg	168-170
Zero 360 2.0kg	113-115
Zero 360 1.5kg	128-130
Stored Pressure Systems	CTRS (mm)
Zero 360 2.25kg Electric/Mechanical	88-90
Zero 360 3.0kg Electric/Mechanical	145-147
Zero 2020 Electric/mechanical	120

WIDTH	
CD Remote Systems	CTRS (mm)
Zero 360	105-107
Stored Pressure Systems	CTRS (mm)
Zero 360 Electric/Mechanical	140-144
Zero 2020 Electric/mechanical	141-145

Section 2 – Delivery Network – Tube and Connectors

Item and System Type	Fixing Type and No.	Location and Fitting Guide				
<p>Tube (8mm) and Over-braid where supplied – All Systems</p>	<p>Supplied clips, cable ties or P-Clips as required</p>	<p>Cut tube to pre-measured length using a dedicated tube cutter, taking note of Figure 5 and Section 6, ensuring that there are no sharp edges and that the tube remains circular. Do not use a hack saw or similar tool; this will leave a jagged edge which will damage the seals in connecting components.</p> <div data-bbox="853 719 1437 943" data-label="Image"> </div> <p>Figure 4 - Correct T-Piece to Nozzle Arrangement (See also Section 6 - System Schematics)</p> <p>Hand form the tube taking care not to create a kink which could restrict flow. Minimum bend radius of the tube is shown below; Lifeline recommend doubling this figure, where possible, to avoid kinking.</p> <table border="1" data-bbox="794 1227 1497 1301"> <thead> <tr> <th>Tube Ø</th> <th>Minimum Bend Radius</th> </tr> </thead> <tbody> <tr> <td>8mm</td> <td>25mm (50mm recommended)</td> </tr> </tbody> </table> <p>Measure and cut over-braid to fit over the cut and formed tube and the back of the nozzles and fittings, finishing with heat shrink to prevent fraying and retain in place</p>	Tube Ø	Minimum Bend Radius	8mm	25mm (50mm recommended)
Tube Ø	Minimum Bend Radius					
8mm	25mm (50mm recommended)					
<p>Connectors</p>	<p>N/A</p>	<p>Where supplied and required, drill a Ø13mm hole and fit the bulkhead connector. Loose lay tubing in the vehicle and start pushing the tube into the connectors. Push the tube until a positive click is felt as the tube goes past the sealing o’ring. Once home it should be impossible to pull the tube free without depressing the release ring on the connector.</p>				

Section 3 – Nozzles

Zero 2020 nozzles produce an 80° fine mist, Zero 360 nozzles a 120° flat fan (blue nozzle) and 160° flat fan (gold nozzle). Consideration should be given to overlaps particularly with Zero 360 nozzles where this can improve system performance. Be aware of obstacles which obstruct the spray pattern.

Zero 2020 and Zero 360 nozzles require a Ø15.5mm panel cut out for fitting. Nozzles must be rigidly mounted on a bracket or panel and not supported by tubing alone. The tubing should be supported 75-100mm behind each nozzle using P-Clips.

Nozzle type is optimised for each system; do not use any nozzle other than the one designed for the system you have. All nozzles must be fitted, no extra nozzles are permitted.

System Type	Cockpit	Engine Compartment
<p>Zero 2020 Systems with 5 nozzles</p>	<p>2 nozzles under the dashboard pointed downwards into the footwell or driver's midriff in open cars. Do not point at occupant's head.</p> <div data-bbox="459 1032 963 1328" data-label="Image"> </div> <p data-bbox="475 1339 948 1361">Figure 5 - Zero 2020 Track Only Nozzle Positions</p> <div data-bbox="459 1368 963 1648" data-label="Image"> </div> <p data-bbox="501 1653 922 1675">Figure 6 - Zero 2020 Rally Nozzle Positions</p> <div data-bbox="488 1686 938 1966" data-label="Image"> </div> <p data-bbox="475 1973 948 1995">Figure 7 - Zero 2020 Single Seat Nozzle Positions</p>	<p>The misting nozzles produce a fine high-volume spray that floods the engine bay. Carefully consider the position of the 3 engine compartment nozzles to cover the most likely source of ignition: induction, exhaust, fuel pump, injector rail, carburettors etc. Two nozzles should be placed on opposite sides of the engine, with the third at one end.</p> <div data-bbox="1010 1290 1497 1883" data-label="Image"> </div> <p data-bbox="1034 1895 1473 1917">Figure 8 - Zero 2020 Engine Nozzle Positions</p>

**FIA 2.25kg & 3.0kg
Zero 360 Stored
Pressure Systems
with 5 nozzles**

2 BLUE nozzles under the dashboard pointed into the footwell or driver's midriff in open cars.

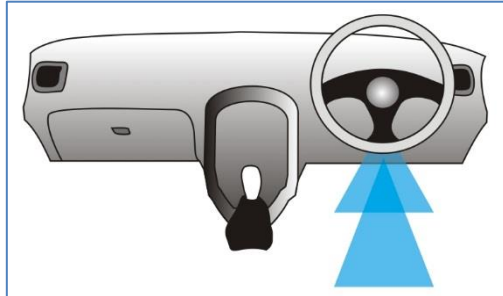

Figure 9 - FIA Zero 360 Track Only Nozzle Positions

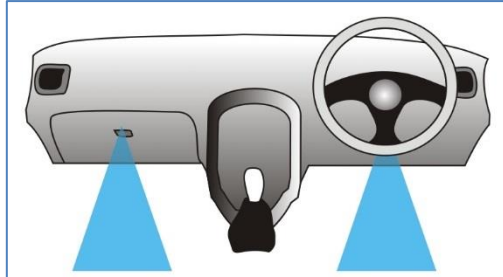

Figure 10 - FIA Zero 360 3.0kg Rally Nozzle Positions

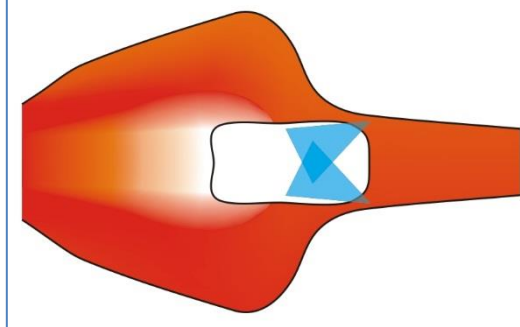

Figure 11 - FIA Zero 360 Single Seat Formula Nozzle Positions

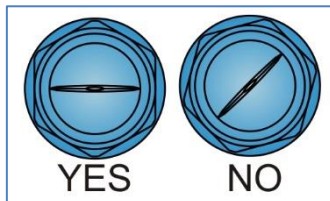

Figure 12 - FIA Zero 360 Cockpit Nozzle Orientation

Position the 3 GOLD nozzles as shown in Figure 15 and between the mid-height and top of the engine.

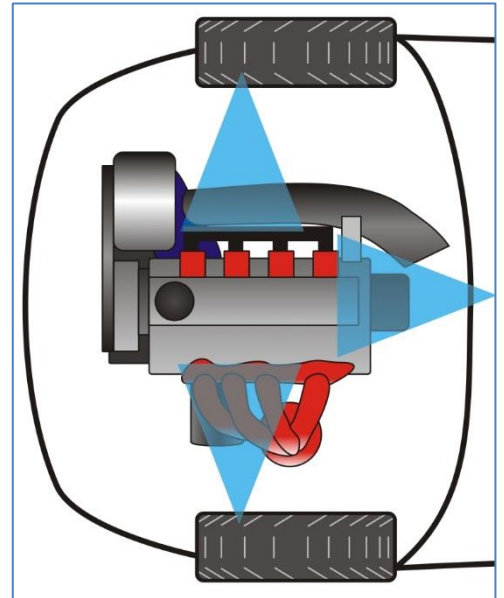

Figure 13 - FIA Zero 360 Engine Nozzle Positions

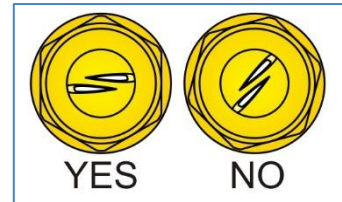

Figure 14 - FIA Zero 360 Engine Nozzle Orientation

FIA 1.5kg, 2.0kg & 3.0kg Zero 360 CD Remote Systems with 4 nozzles

As Zero 360 stored pressure systems above, using the two BLUE nozzles

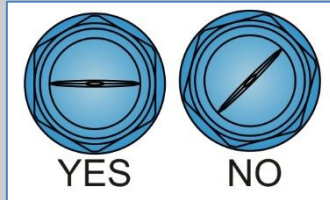

Figure 15 - FIA Zero 360 Cockpit Nozzle Orientation

Position the 2 GOLD nozzles as shown in Figure 18 and between the mid-height and top of the engine.

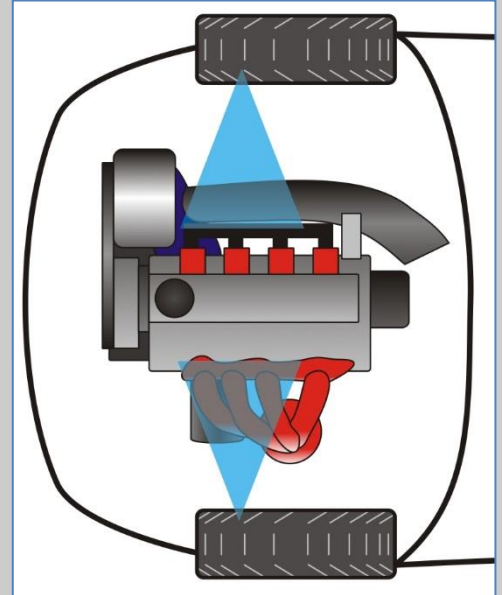

Figure 16 - FIA Zero 360 CD Engine Nozzle Positions

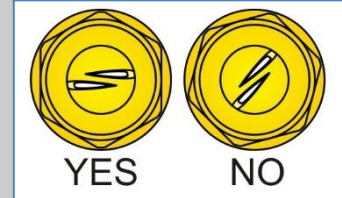

Figure 17 - FIA Zero 360 CD Engine Nozzle Orientation

Section 4 – Activation – Mechanical and Electrical

Item and System Type	Location and Fitting Guide
<p>Pull Cable(s) – All Mechanical Systems</p>	<p>Mechanical systems are supplied with 2 Bowden cables, one internally and one externally. Both must be fitted in closed cockpit vehicles and, depending on regulation, only the internal or both in open cockpit vehicles.</p> <p>The pull cable bezels require a Ø10.5 – Ø11.5mm panel cut out.</p> <p>The external cable is normally located in the scuttle area on closed cockpit vehicles and must be near to the electrical cut-off switch. Position on open cockpit vehicles is on the roll hoop. The supplied “E” sticker should be fixed immediately next to the T-handle of the pull cable.</p> <p>The internal cable is normally located on the dashboard near to the electrical cut-off switch and must be reachable by the driver or co-driver when seated with belts on.</p> <p>Route the outer part of the Bowden cables into the brass ferrule on the handle and ensure that the nipple is secure on the other side of the handle, as per the diagram on page 11. Torque the nipple screw to at least 0.5 Nm.</p> <p><i><u>Special care must be taken with routing to ensure no sharp bends or S-bends are introduced to the cable. This can significantly increase the effort required to pull the cable. Once the routing is decided upon, trial fit the cable without connecting to the extinguisher to test for smooth and easy operation. It is recommended that 10mm of slack is left to prevent accidental firing and so that scrutineers can confirm the cables are free</u></i></p>
<p>Wiring – All Electrical Systems including CD Remote</p>	<p>Switches are to be located as above for mechanical systems. Take care not to position the switches next to other parts of the vehicle which could be confused for the switch e.g. unused wiper towers. The switches require a Ø13.6mm panel cut out. The supplied “E” sticker should be fixed immediately next to the switch.</p> <p>Wire the system as per the diagram below. Circuit has no polarity, but it is recommended that the wire colours are matched for clarity and to aid troubleshooting.</p> <div data-bbox="395 1680 1420 1948" data-label="Diagram"> </div>

Figure 18 - Wiring Schematic

Section 5 – System Checking

System Type	Procedure
All Systems	<p>Where fitted check that the pressure gauge is in the centre of the scale, pressure in cylinders can vary with temperature due to the expansion and contraction of the suppressant; this is normal. For CD Remote systems, where no pressure gauge is fitted, the cylinder should be weighed and checked against the weight shown on the serial label. It is likely that there will be some deviation; Lifeline use scales which are regularly UKAS calibrated, it cannot reasonably be expected that a reading taken either by you or at scrutineering will perfectly match.</p>
Mechanical	<p>Leaving the safety pin in, check movement of the cables by pulling the T-handle until slack is taken up and then push the T-handle fully back into its housing. If a restriction is felt that could be considered detrimental to the operation of the extinguisher, check cable routing and lubricate the cable until movement is smooth.</p>
Electrical	<p>Once the system has been wired in accordance with the wiring diagram shown in Section 4, a check should be carried out to ensure that the system will discharge. Before you start the check procedure, ensure that the bottle and the power pack are connected.</p> <p>On the front of the power pack is a three-position switch. This provides checking facilities for the battery and wiring. Moving the switch downwards against its spring will illuminate the AMBER LED.</p> <p><u><i>If the LED does not light, or immediately goes out, the battery should be replaced. The battery should be replaced with a good quality PP3 Alkaline type only.</i></u></p> <p>With the switch in the centre “SYSTEM TEST” position, and the centre position only, the wiring of the circuit can be checked. With the extinguisher connected, press one of the firing buttons and the green LED will illuminate. If it does not, there is a break in the circuit. If the LED illuminates before the switch is pressed, there is a short in the circuit and the system is permanently ‘live’.</p> <p><u><i>If this occurs, do not put the switch into the “SYSTEM ARMED” position because you will discharge the system.</i></u></p> <p>If for any reason the green LED does not illuminate when the system is tested, check the wiring against the wiring diagram shown in Section 4.</p> <p>To arm the system, move the switch upwards to the ‘SYSTEM ARMED’ position. The red LED will illuminate to showing that the system is armed.</p> <p>To prolong battery life and prevent accidental activation, it is recommended that the power pack switch be to the ‘SYSTEM TEST’ position and the plug disconnected from the power pack when the vehicle is not being used.</p>

Section 6 – System Schematics

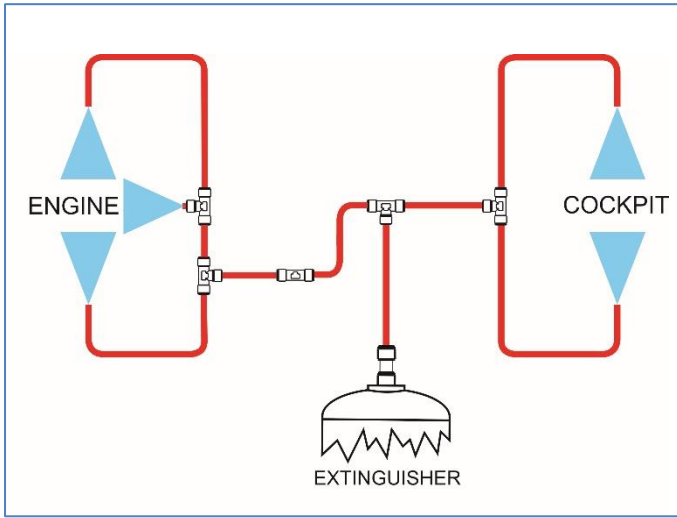

Figure 19 - All Zero 2020 Systems - 106-001-011, 106-001-012

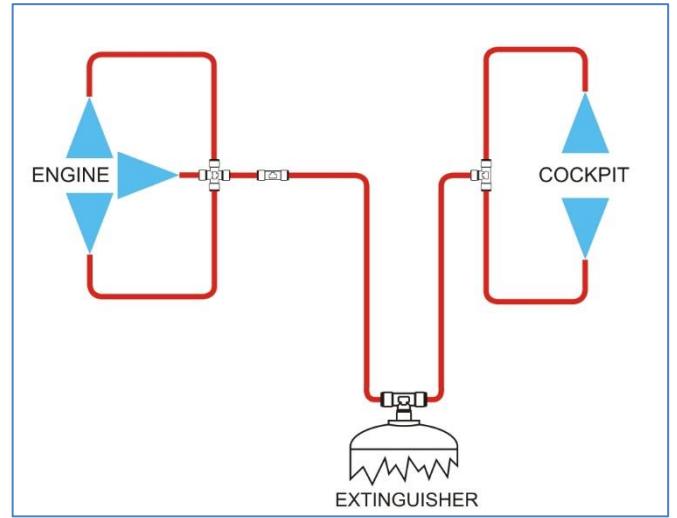

Figure 20 - All Zero 360 Stored Pressure Systems - 106-001-004, 106-001-005, 106-001-007, 106-001-008

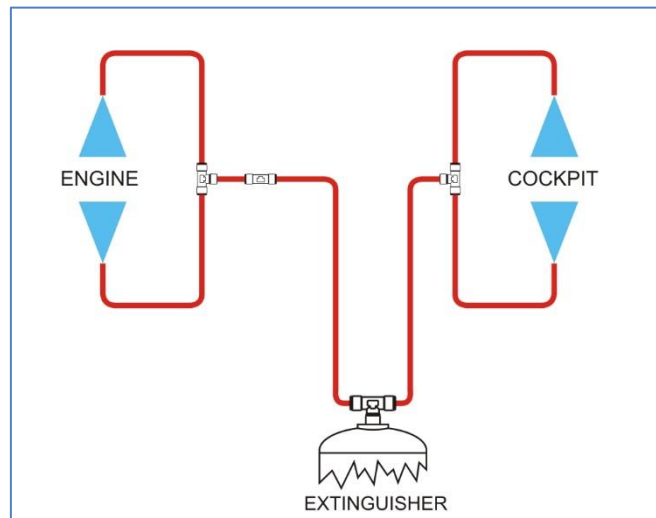

Figure 21 - All Zero 360 CD Remote Systems - 106-001-003, 106-001-006, 106-001-009

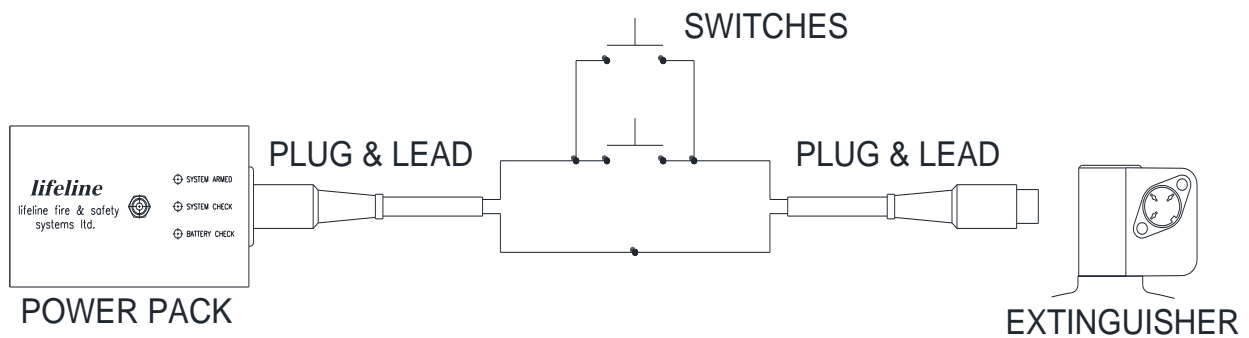

Figure 22 - Wiring Schematic for Electrical Systems

Torque Nipple to 0.5 Nm

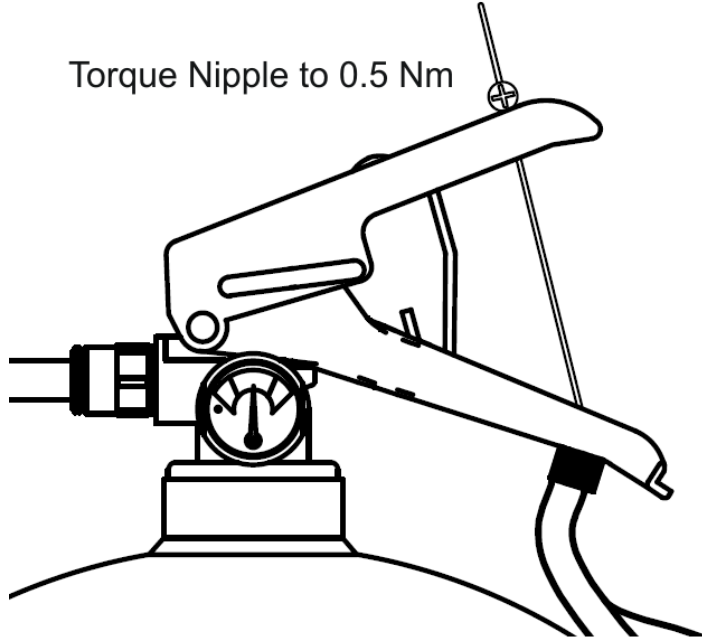

Figure 23 Mechanical Pull Cable Fitment

System Part Number	
System Serial Number	
Date of Manufacture	
Service 1 Date	
Service 2 Date	
Service 3 Date	
Service 4 Date	
Service 5 Date	

Notes