



MULTI-FLO AFFF SYSTEMS

&

Formula Systems

FIA HOMOLOGATION NUMBER: - EX.046.17 &
EX.050.18 & EX.051.18

Installation Instructions

**Please read carefully before
attempting to install
your system.**



The Mill House, Tamworth Road, Packington Hayes
Nr Lichfield, Staffordshire, England WS14 9PN
Tel: 01543 434580 Fax: 01543 434581
E-mail: sales@spa-uk.co.uk
Web Site: www.spa-uk.co.uk

Firefighter/ Firesense-Response AFFF Multi-flo Systems covered by this manual

<input type="checkbox"/>	MFE400A-4-A	4 Ltr Electrical/Auto Alloy
<input type="checkbox"/>	MFM400A-4-A	4 Ltr Mechanical/Auto Alloy
<input type="checkbox"/>	MFM400A-4	4 Ltr Mechanical Alloy
<input type="checkbox"/>	MFE400S-4-A	4 Ltr Electrical/Auto Steel
<input type="checkbox"/>	MFM400S-4-A	4 Ltr Mechanical/Auto Steel
<input type="checkbox"/>	MFM400S-4	4 Ltr Mechanical Steel
<input type="checkbox"/>	MFE75A-4-A	3.375 Ltr Electrical/Auto Alloy
<input type="checkbox"/>	MFM75A-4-A	3.375 Ltr Mechanical/Auto Alloy
<input type="checkbox"/>	MFM75A-4	3.375 Ltr Mechanical Alloy
<input type="checkbox"/>	MFE75S-4-A	3.375 Ltr Electrical/Auto Steel
<input type="checkbox"/>	MFM75S-4-A	3.375 Ltr Mechanical/Auto Steel
<input type="checkbox"/>	MFM75S-4	3.375 Ltr Mechanical Steel
<input type="checkbox"/>	MFE75A-4-A-SL	3.375 Ltr Electrical/Auto Alloy Slimline
<input type="checkbox"/>	MFM75A-4-A-SL	3.375 Ltr Mechanical/Auto Alloy Slimline
<input type="checkbox"/>	MFM75A-4-SL	3.375 Ltr Mechanical Alloy Slimline
<input type="checkbox"/>	MFE400A-4	4 Ltr Electrical Alloy
<input type="checkbox"/>	MFE225A	2.25 Ltr Electrical alloy Slimline
<input type="checkbox"/>	MFM225A	2.25 Ltr Mechanical Alloy Slimline



The Mill House, Tamworth Road, Packington Hayes
Nr Lichfield, Staffordshire, England WS14 9PN. UK

Tel: 01543 434580 Fax: 01543 434581

E-mail: sales@spa-uk.co.uk

Web Site: www.spa-uk.co.uk

Thank you for purchasing a FireSense-Response AFFF Multi-flo or Formula System (which has been FIA homologated).

It is important that you read the following instructions carefully before attempting to install your fire suppression system.

The performance of this system will be affected if it is in anyway modified or tampered with it will void its homologation. Please ensure that should any parts need to be replaced, only genuine SPA FireSense-Response components are used.

Should you require any assistance, please do not hesitate in contacting SPA Design on 01543 434580.

IMPORTANT NOTE

The purpose of this along with any other vehicle fire suppression system is to provide sufficient time in which to control the fire to enable the occupants to leave the vehicle.

In ideal conditions, the fire will be extinguished completely but this can not be guaranteed. The main purpose is to curb the intensity of either an engine or cockpit fire to provide the means for the occupants to leave the vehicle or for outside assistance to be given.

Automatic Head

The new activation valve fitted to certain models all ending with the letter A within this new range of systems has a special safety feature that does not interfere with the standard operating procedure of the fire suppression system.

The automatic activation feature is a stand alone activation that will operate independent on user input at a temperature specified by the manufacturer.

IMPORTANT NOTE

The fire suppression system requires input by the user by either mechanical cable pull or electrical switch to operate the automatic activation is a safety backup only it is not the primary means of activation the primary means of activation is the driver using the cable pull or electrical switch depending on model purchased.

C O N T E N T S

Fitting Instructions – Electrical System	Page 5-8
Fitting Instructions – Mechanical System	Page 9-11
Cylinder mounting	Page 12-13
Nozzles & Installation	Page 14-16
Tubing	Page 17
Kit Lists Component Check	Page 18-20
System Maintenance	Page 21
Bottle Dimensions	Page 22-27
Pipework & Nozzle layout	Page 28-31
Safety Data Sheet	Page 32
Agents	Page 33-36

SPA FIRESENSE-RESPONSE ELECTRICAL SYSTEM WIRING SCHEMATIC APPLIES TO ALL ELECTRIC MODELS

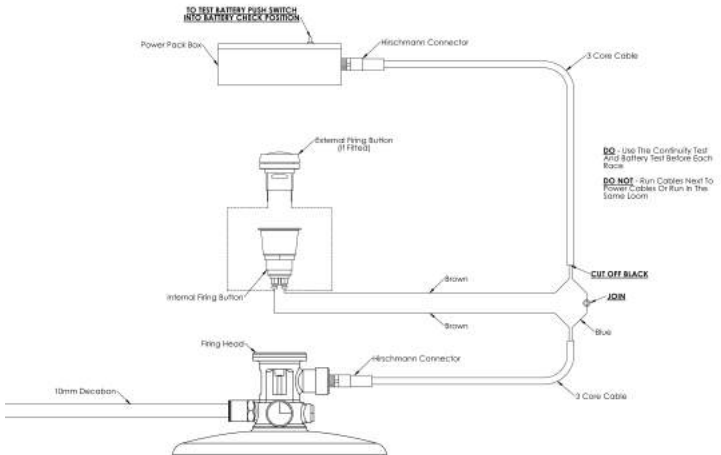

- To test the battery, push and hold control box switch upwards in the "Battery Check" position until yellow light flashes.
- If the extinguisher tubing is to be removed, push the black collet in and pull the tubing out at the same time.

RECOMMENDED: Use the continuity test and battery test before each race.

DO NOT: Run the cables next to power cables, or in the same loom.

ELECTRICAL FITTING INSTRUCTIONS

Unpack all parts and check components against 'kit list'.

- Remove bottle from mounting brackets if fitted by undoing the wing nuts. Decide the best position for the extinguisher – **IT IS RECOMMENDED THAT THE BOTTLE SHOULD BE MOUNTED IN THE FORE AND AFT DIRECTION OF THE VEHICLE.**
The extinguisher label, detailing the contents and the pressure gauge should be clearly visible for inspection, Mount the retaining brackets securely to the vehicle and put the bottle back into place.
(Refer to Figure 3.)
- Mount the power pack in a clearly visible position.
- Switch with red plastic shroud to be fitted in the cockpit so that it is in easy reach of both the driver and/or co-driver when sitting in the normal driving position and wearing fully fastened seat-belts.
- The other switch with flexible red membrane (waterproof) is to be fitted to the outside of the vehicle, close to the exterior master switch (for activation by the Marshals).
- Once the system has been wired as per wiring diagrams *(refer to Figure 1 / 2)*, the following tests should be carried out to check the system is fitted correctly and will operate when required. *(See Page 5)*

SPA DESIGN FIRESENSE-RESPONSE ELECTRICAL DETAILS

The SPA FireSense-Response system uses actuators to operate valves located within the pressurized container that contains the extinguishant. These are triggered remotely using a battery-powered power pack.

In order to guarantee reliable operation the connectors used are 1P67 and the actuators used are of a military specification with the system / battery test electronics integrated into the power pack.

The power pack electronics can test the continuity of the wiring, and also provides a high current pulse test to ensure system integrity before use. Unlike other systems, the battery test will not destroy or put an excessive drain on the battery during this critical test. These tests are performed using a three way switch on the power pack box and should be performed before each usage of the system, since the system is only as good as the battery that powers it and the integrity of the wiring loom and its connectors.

To check the condition of the battery press and hold up the switch on the power pack box in battery check position. **Every two seconds you will see a YELLOW light flash.**

If the light flashes very dimly the battery must be replaced.

IF IN DOUBT REPLACE THE BATTERY !!!!

To check the continuity of the wiring, ensure that the switch on the power pack box is in the **SYSTEM INACTIVE** position to ensure that the extinguisher is not fired.

Press the internal firing button and check that the **RED** light comes on, press the external firing button, and check that this also makes the **RED** light come on.

The external button must be positioned close to the exterior master switch.

When you are ready to race after all these checks push switch into system armed position, **the control box will not illuminate in the system armed position** if either internal or external switches are pressed the system will activate.

DO ensure that the wiring cables do not run next to looms especially if they contain ignition or battery cables

DO ensure that any exposed connections that are likely to get water sprayed are protected.

DO NOT allow cables to run through sharp edged apertures without protection

DO NOT fix cables to any surface that is likely to see excessive temperatures.

MECHANICAL CABLE SETUP

LEVER VALVE

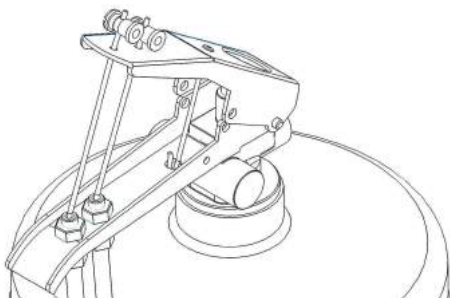

MECHANICAL AUTO HEAD

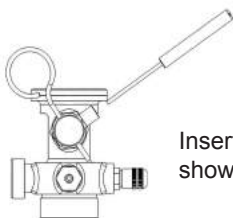

Insert cable pull into hole location as shown.

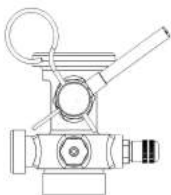

Make sure Cable is secure.



Once cable is secure, remove safety pin before race, when race is finished replace safety pin.

MECHANICAL SYSTEM

The system uses two T-handle pull cables, one 6ft long and one 12 ft long.

- Remove bottle from mounting brackets if fitted by undoing the wing nuts. Decide the best position for the extinguisher – **IT IS RECOMMENDED THAT THE BOTTLE SHOULD BE MOUNTED IN THE FORE AND AFT DIRECTION OF THE VEHICLE.** The extinguisher label, detailing the contents and the pressure gauge should be clearly visible for inspection, Mount the retaining brackets securely to the vehicle and put the bottle back into place. (*refer to Figure 3*).
- Insert the end of the Decabon tube into the push-in fitting on the lever-valve and lay the length of the tube from the cylinder to the chosen location; plug the nozzle onto the free end of tube and orientate this to point the nozzles onto anticipated fire sources.
- Mount the 6-ft cable in the cockpit within reach of the driver and / or co-driver when sitting in the normal driving position wearing seat-belts. The other end of the cable is to be threaded through one of the adjusting screws on the handle of the lever-valve (on the cylinder). Then threaded through one of the holes in the other handle and the clamp screw made secure on cable against the underside in such a way that movement of the red pull handle will close the handles of the lever-valve, **BUT** allowing 6mm of free-play. **CAUTION:** do not allow this testing to actually move the handles or the valve may open and release the extinguishant (keep the safety pin in place).

- Mount the 12-ft cable on the outside of the vehicle (close to the exterior master switch is the recommended position). Lay the cable inside the vehicle and connect to the lever-valve as above.
- Pull cables should be fitted in such a way that no kinks or 'S' bends are formed, which could cause malfunction.
- Removing the safety pin from the lever-valve leaves the system ready for use.
- **SAFETY WARNING Failure to remove safety pin will render the system inoperable when required.**

EXTINGUISHER
MOUNT BRACKET

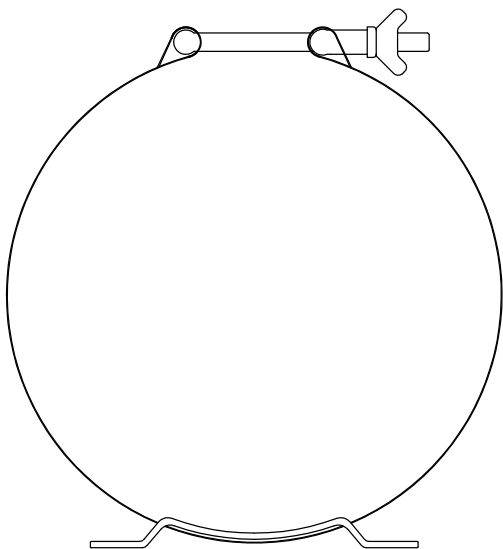

SP144 – 6" Cylinder Retaining Bracket
SP148 - 5" Cylinder Retaining Bracket

ANTI TORPEDO MOUNT MANDATORY
ON ALL FIA SYSTEMS

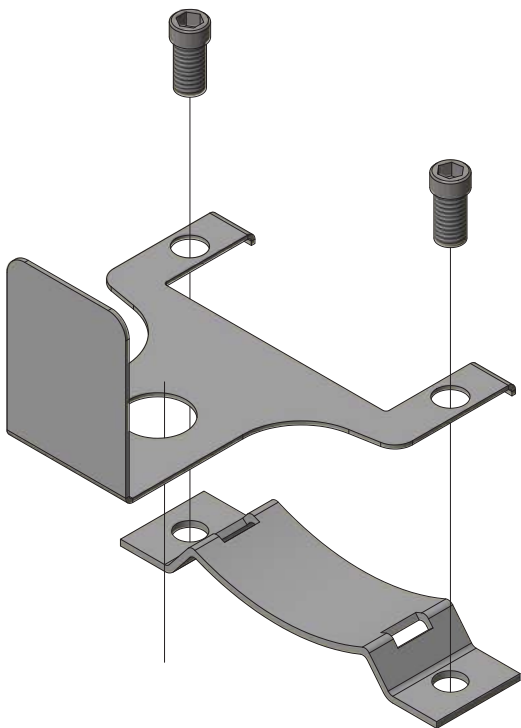

A.F.F.F. NOZZLES

It is important that all of the nozzles provided in the fire system kit are used.

The nozzles will produce a fine atomized spray with the AFFF emerging as a milky white foam substance, which forms a film barrier starving the fire of oxygen. This foam spray has the capability of excellent fire out times and has a cooling effect, which can control re-ignition.

When locating the nozzles it should be noted that there is a 90° cone with a 1/2 meter spray.

Nozzles should not simply be supported by their own pipe work. Where necessary support the nozzle in a bracket.

Nozzles should be checked for damage/possible blockage. They should also be tested to ensure that they are in good working order.

Depending on the class of racing/rallying,(which is the competitors responsibility) e.g. International rallying, which needs a 4lt system, the engine bay must have 2 nozzles installed, with one each side of the motor and 2 nozzles installed in the cockpit.

For open cars, the system must include two nozzles one should be aimed at the drivers midriff with special care being taken not to spray into the drivers face.

For saloon /closed cars 2 nozzles must be fitted within the cockpit area. Nozzles should be fitted either to the top of the roll bar main hoop (door B pillar) pointing inwards and downwards towards the foot of the diagonally opposite front roll bar hoop base (door A post) or either under the dashboard aiming at the drivers midriff.

These are guide lines for competitors using SPA Design fire suppression systems

IF IN DOUBT, ASK!!!

Example of Cockpit nozzle location
Saloon Cars Only.

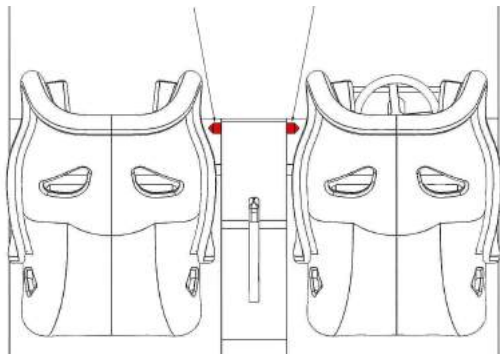

EXAMPLE OF ENGINE NOZZLE LOCATION

Saloon & Single Seaters

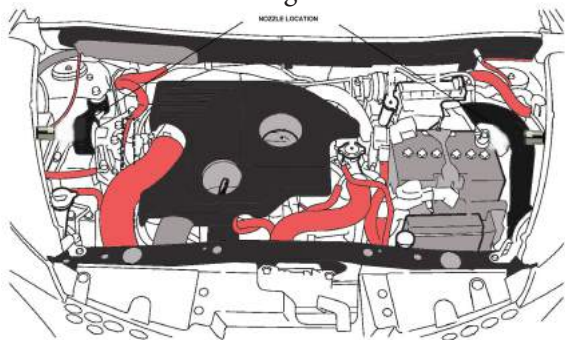

COCKPIT NOZZLE LOCATION FOR SINGLE SEATERS, THIS APPLIES ONLY TO MODELS MFM225A, MFE225A, MFE75A, MFM75A, MFE75S, MFM75S, MFE75A-SL & MFM75A-SL

The SP030 Cockpit nozzles are positioned to aim at the drivers midriff as shown in the image below.

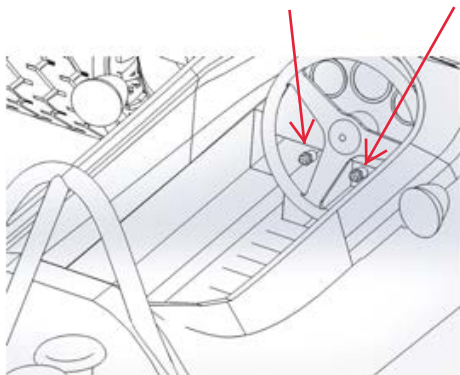

TUBING

Each FireSense-Response System kit is supplied with Decabon tubing which is a coated aluminium tube which can be molded and flexed to suit this application. The FireSense-Response system has been designed and homologated using 10mm & 8mm dia tube. DO NOT substitute this tube for any other type.

TUBE CONNECTIONS

All fittings for tube to nozzles and bottle are of the push-in type. Insert the tube into the fitting, push firmly until it clicks. Once in you should not be able to pull it out.

To remove the tubing, push the tube into the fitting and at the same time push/pull the black collet back towards the fitting and then pull the tube from the fitting.

KIT LISTS

4 LTR & 3.375 Ltr Multi-Flo Electrical

Electrical system comes fitted with firing head.

- 2 x SP144 – 6” Cylinder Retaining Bracket
- 2 x SP319 – 6” Anti Torpedo Mounting Tab
- 1 x SP007H – Power Pack (Hirschman as standard)
- 2 x SP005H – Plug & Lead
- 1 x SP011 – Internal Fire Button
- 1 x SP012 – External Fire Button
- 4.5 x SP032 - 8mm Decabon Tubing (Mtr)
- 0.5 x SP072 - 10mm Decabon Tubing (Mtr)
- 4 x SP031 – 8mm Nozzle
- 2 x SP028 – 8mm Tee
- 1 x SP029 – 8mm Bulkhead Fitting
- 1 x SP183 - 10mm-8mm Y Piece connector
- 1 x SP017 – ‘E’ location sticker
- 1 x SP129 – Small ‘E’ Location Sticker

4 Ltr & 3.375 Ltr Multi-Flo Mechanical

Mechanical System comes fitted with Lever Valve or Mechanical Head

- 2 x SP144 – 6” Cylinder Retaining Bracket
- 2 x SP319 – 6” Anti Torpedo Mounting Tab
- 1 x SP018 - 6ft Pull Cable
- 1 x SP019 – 12ft Pull Cable
- 4 x SP031 – 8mm Nozzle
- 2 x SP028 – 8mm Tee Piece
- 1 x SP029 – 8mm Bulkhead Fitting
- 1 x SP183 - 10mm-8mm Y Piece connector
- 4.5 x SP032 – 8mm Decabon Tubing (Mtr)
- 0.5 x SP072 - 10mm Decabon Tubing (Mtr)
- 1 x SP017 – ‘E’ Location Sticker
- 1 x SP129 – Small ‘E’ Location Sticker

KIT LISTS
MFM225-A

2 x SP147	5" Mounting brackets
2 x SP319	Anti-torpedo mounts
1 x SP018	6 Foot mechanical cable
1 x SP019	12 Foot mechanical cable
1 x SP017	Large E sticker
1 x SP129	Small E sticker
0.5 x SP072	10mm Dekabon Tubing
1 x SP183	10mm-8mm Y piece
1 x SP029	8mm Bulkhead connector
1 x SP028	8mm T piece
3 x SP032	8mm Dekabon tubing
1 x SP184	8mm-6mm Y piece
2 x SP016	6mm Dekabon tubing
2 x SP030	6mm AFFF nozzles
2 x SP031	8mm AFFF nozzles

KIT LISTS
MFE225A

2 x SP147	5" Mounting brackets
2 x SP319	Anti-torpedo mounts
1 x SP007H	Hirschman Style power pack
2 x SP005H	Hirschman plug & Lead
1 x SP011	Internal switch
1 x SP012	External switch
1 x SP017	Large E sticker
1 x SP129	Small E sticker
0.5 x SP072	10mm Dekabon Tubing
1 x SP183	10mm-8mm Y piece
1 x SP029	8mm Bulkhead connector
1 x SP028	8mm T piece
3 x SP032	8mm Dekabon tubing
1 x SP184	8mm-6mm Y piece
2 x SP016	6mm Dekabon tubing
2 x SP030	6mm AFFF nozzles
2 x SP031	8mm AFFF nozzles

MAINTENANCE

To ensure maximum possible performance from your SPA Fire FireSense Response system, the following checks and maintenance procedures should be carried out.

- Regularly check the pressure gauge to ensure they are in the green section.
- Regularly check nozzles for debris or any obstructions externally and internally.
- Regularly check the integrity of the pipe work and fitting.
- Regularly check the cylinder for physical damage or corrosion.
- Regularly check the mounting brackets, retaining straps and bolts are secure.
- Regularly check your power pack control box and condition of the internal alkaline battery, the battery should be changed preferably every 6 months or if system has been fired off.
- Regularly check your wiring and electrical connectors for any damage.
- If the system has been activated the nozzles and pipe work should be washed through with fresh water and then cleared with an air line if possible to avoid residue of the extinguishant crystallizing in the pipe work or nozzles.
- Your SPA fire suppression system must be serviced every 2 years, a service due date is written on the contents label located on your cylinder. It is up to you to ensure the services are carried out at the correct intervals.
- If your system has been discharged or requires a 2-year service you must return it to SPA or an approved agent of SPA fire suppression systems.

NOTES

Please ensure that you monitor the following, as you **may not** pass scrutineering **if**:

- The needle on the gauge is in the red section
- The bottle contents label is worn, damaged or unreadable.
- The unit is not within the service date.
- The system is in a poor condition

BOTTLE DIMENSIONS

Ό [ς ^ ! • Á ς || | , ā * Á ς [á ^ ! •



T Ø01 €€0# €€
T ØT I €€0# €€

T Ø075A-4-A
MFM75A-4-A

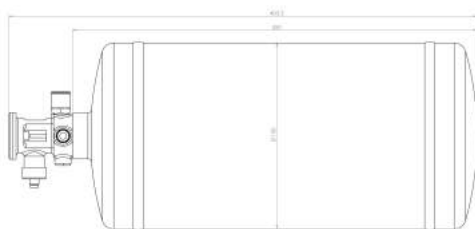

MFE400S-4-A
MFM400S-4-A

MFE75S-4-A
MFM75S-4-A

BOTTLE DIMENSIONS

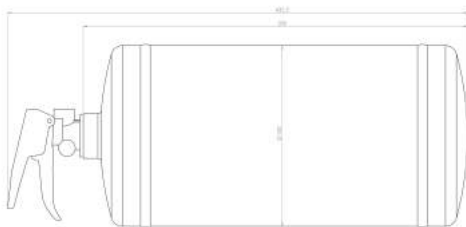

MFM400S-4
MFM75S-4



MFM400A-4
MFM75A-4

BOTTLE DIMENSIONS



MFE75-A-4-A-SL
MFM75A-4-A-SL

MFE225A

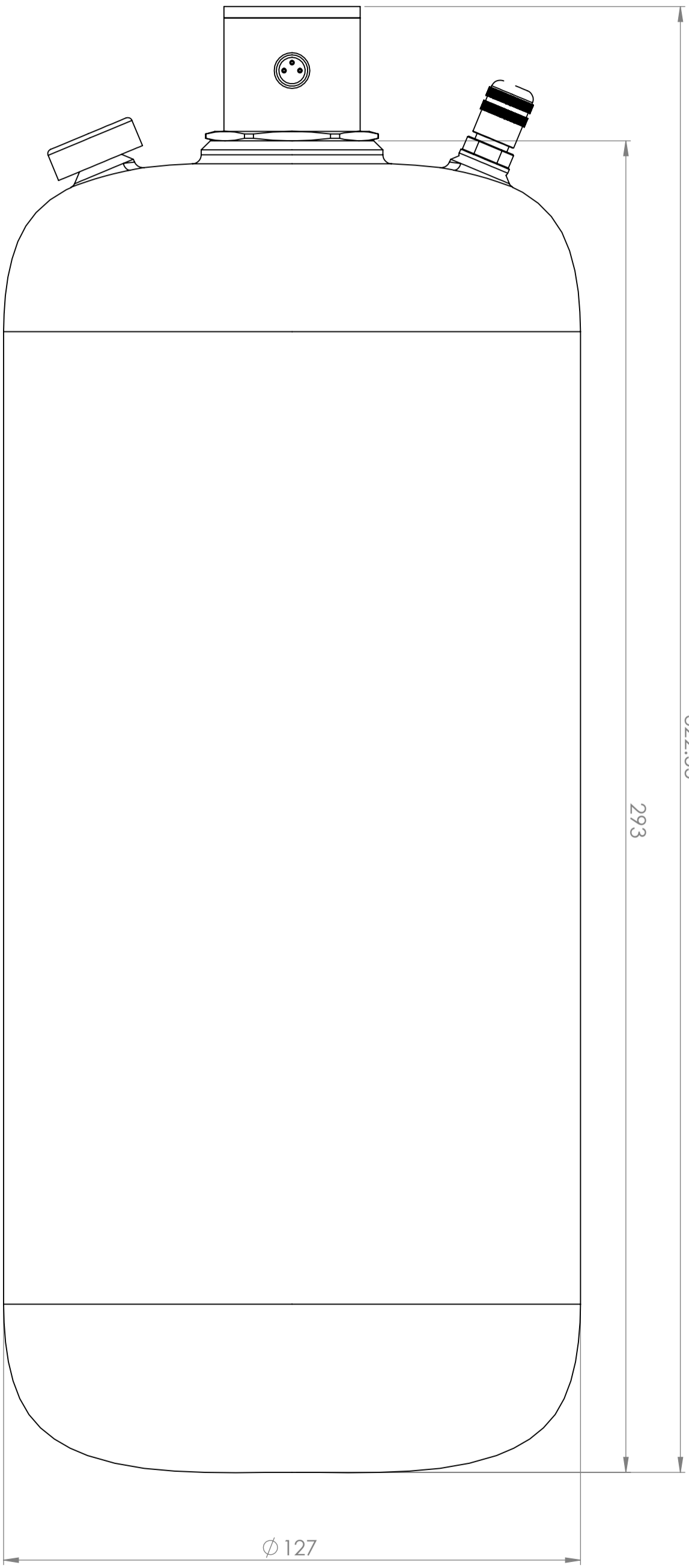

322.55

293

Ø 127

SCALE 1 : 1



APP'VD	NAME	DATE	REVISION	MODIFICATION	NAME	DATE
			XX	± 0.381		
			XX.X	± 0.254		
			XX.XX	± 0.127		
			XX.XXX	± 0.051		
			XX.XXXX	± 0.025		
			ANGULAR ± 0.5°			
			SURFACE FINISH 0.8 µm			

PENSKE RACING SHOCKS UK	
TITLE:	AFFF 2.25L Electrical
DWG NO.:	
FINISH:	
WEIGHT:	
MATERIAL:	
REVISION:	

THIS DRAWING / OR DOCUMENT IS COPYRIGHT AND THE PROPERTY OF SPA AUTOMOTIVE LTD. IT MUST NOT BE COPIED (IN WHOLE OR IN PART) USED FOR MANUFACTURE OR OTHERWISE DISCLOSED WITHOUT PRIOR WRITTEN CONSENT OF THE COMPANY. ANY COPIES OF THIS DRAWING MADE BY ANY METHOD MUST ALSO INCLUDE A COPY OF THIS LEGEND.	IF IN DOUBT - ASK
---	-------------------

DO NOT SCALE DRAWING	SCALE: 1:5	SHEET 1 OF 1	A3
----------------------	------------	--------------	----

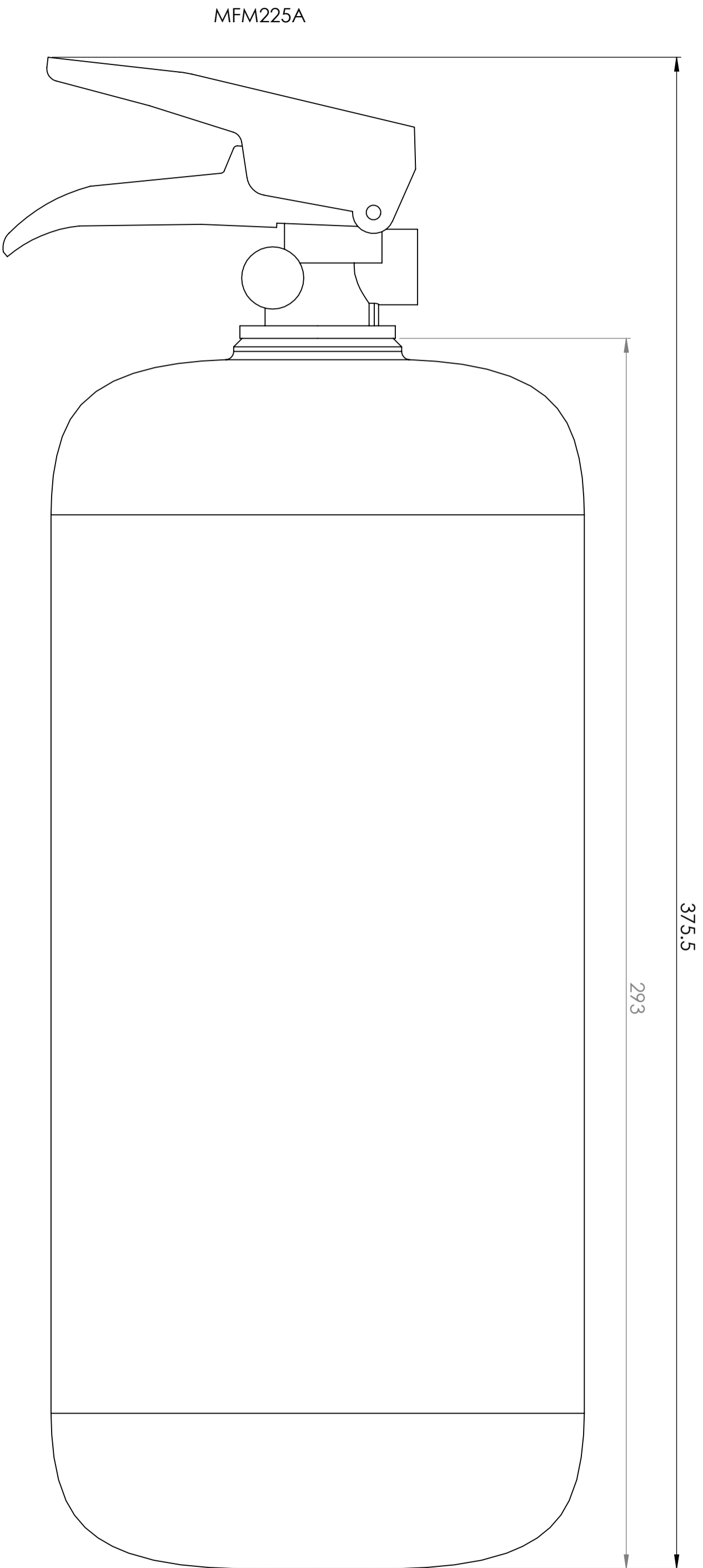

SCALE 1 : 1



APP/VD	NAME	DATE	REVISION	MODIFICATION	NAME	DATE
DRAWN			XX			
			XX.X			
			XX.XX			
			XX.XXX			
			XX.XXXX			
			ANGULAR ± 0.5°			
			SURFACE FINISH 0.8 µm			
				DEBUR AND BREAK SHARP EDGES		
				IF IN DOUBT - ASK		

UNLESS OTHERWISE SPECIFIED:
DIMENSIONS ARE IN MILLIMETERS
APPLY STANDARD PENSKE
TOLERANCES

± 0.381
± 0.254
± 0.127
± 0.051
± 0.025

PENSKE RACING SHOCKS UK

TITLE: Mechanical 2.25L AFFF

DWG NO.:

FINISH:

MATERIAL:

DO NOT SCALE DRAWING SCALE: 1:5

WEIGHT:

REVISION

SHEET 1 OF 1

A3

THIS DRAWING / OR DOCUMENT IS COPYRIGHT AND THE PROPERTY OF SPA AUTOMOTIVE LTD.
IT MUST NOT BE COPIED (IN WHOLE OR IN PART) USED FOR MANUFACTURE OR OTHERWISE
DISCLOSED WITHOUT PRIOR WRITTEN CONSENT OF THE COMPANY. ANY COPIES OF THIS
DRAWING MADE BY ANY METHOD MUST ALSO INCLUDE A COPY OF THIS LEGEND.

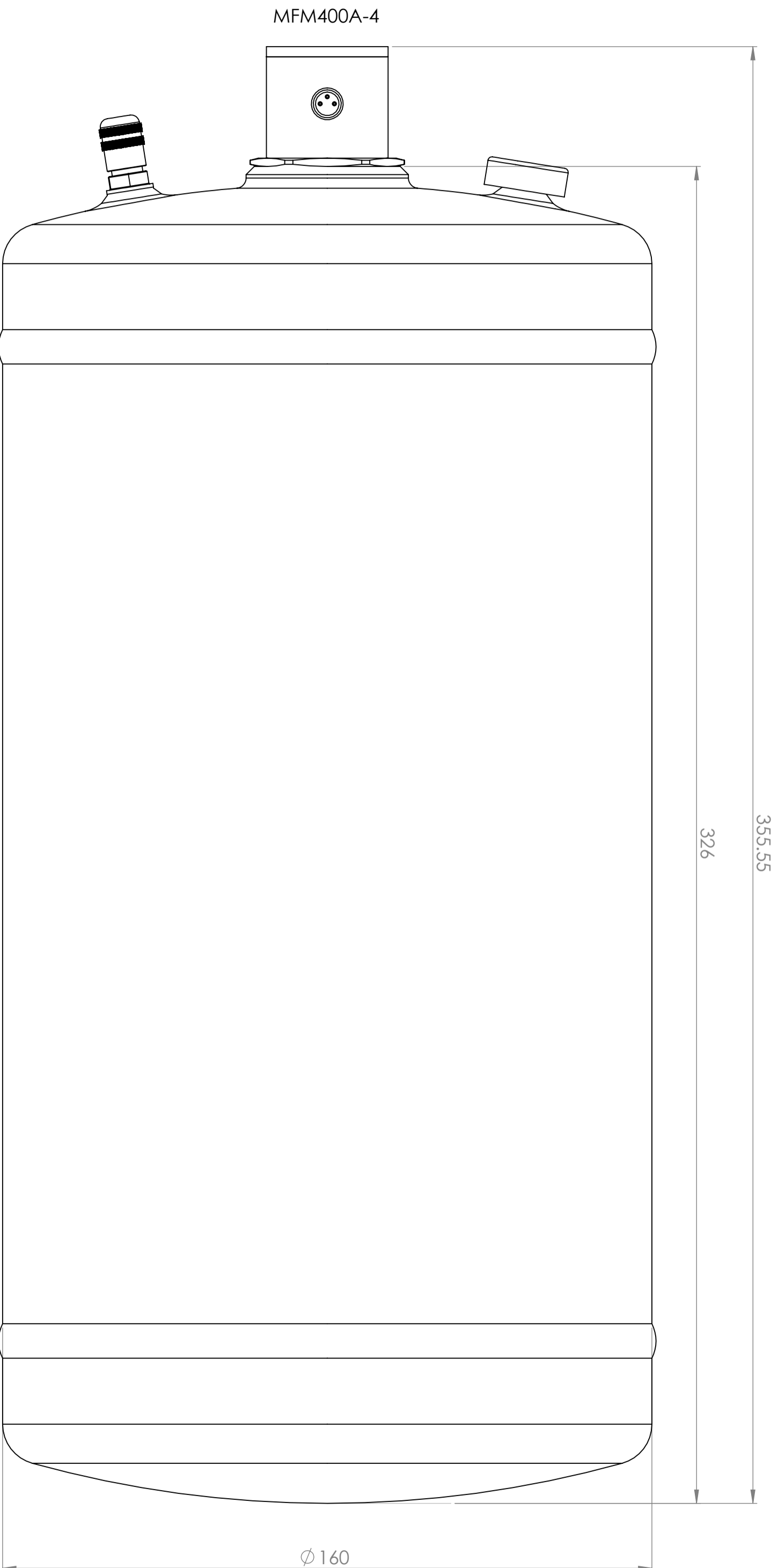

SCALE 1 : 1



APPVD	NAME	DATE	REVISION	MODIFICATION	NAME	DATE
DRAWN			XX			
			XX.X			
			XX.XX			
			XX.XXX			
			XX.XXXX			
			ANGULAR ± 0.5°			
			SURFACE FINISH 0.8 µm			
				DEBUR AND BREAK SHARP EDGES		
				IF IN DOUBT - ASK		

UNLESS OTHERWISE SPECIFIED:
DIMENSIONS ARE IN MILLIMETERS
APPLY STANDARD PENSKE
TOLERANCES

± 0.381
± 0.254
± 0.127
± 0.051
± 0.025

PENSKE RACING SHOCKS UK

TITLE: AFFF 4.0L Electrical

DWG NO.:

FINISH:

MATERIAL:

DO NOT SCALE DRAWING SCALE: 1:5

REVISION

WEIGHT:

SHEET 1 OF 1

A3

THIS DRAWING / OR DOCUMENT IS COPYRIGHT AND THE PROPERTY OF SPA AUTOMOTIVE LTD.
IT MUST NOT BE COPIED (IN WHOLE OR IN PART) USED FOR MANUFACTURE OR OTHERWISE
DISCLOSED WITHOUT PRIOR WRITTEN CONSENT OF THE COMPANY. ANY COPIES OF THIS
DRAWING MADE BY ANY METHOD MUST ALSO INCLUDE A COPY OF THIS LEGEND.

Pipework and Nozzle Layout Electrical and Mechanical Systems

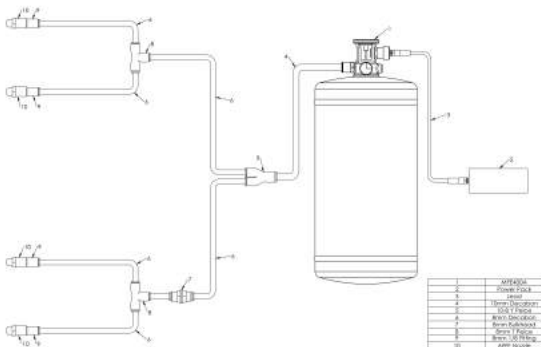

MFE400A-4-A
MFE75A-4-A

MFE400S-4-A
MFE75S-4-A
MFE75A-4-A-SL

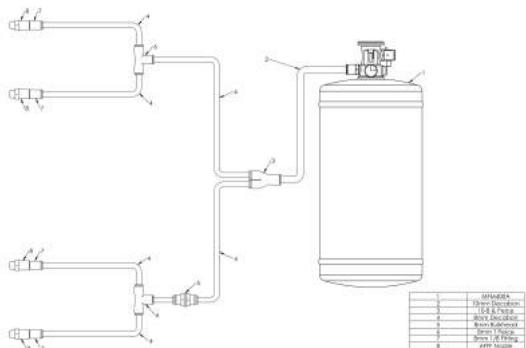

MFM400A-4-A
MFM75A-4-A

MFM400S-4-A
MFM75S-4-A
MFM75A-4-A-SL
MF400A-4

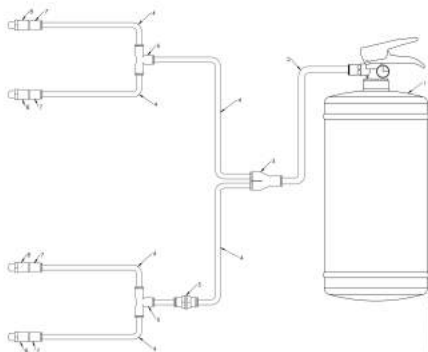

MFM400S-4
MFM400A-4
MFM75S-4
MFM75A-4
MFM75A-4-SL

1	Nozzle
2	Shim Decoupler
3	1/2" Tee
4	Shim Coupler
5	Shim Bulkhead
6	Shim Tee
7	Shim Tee Tee
8	Shim Tee

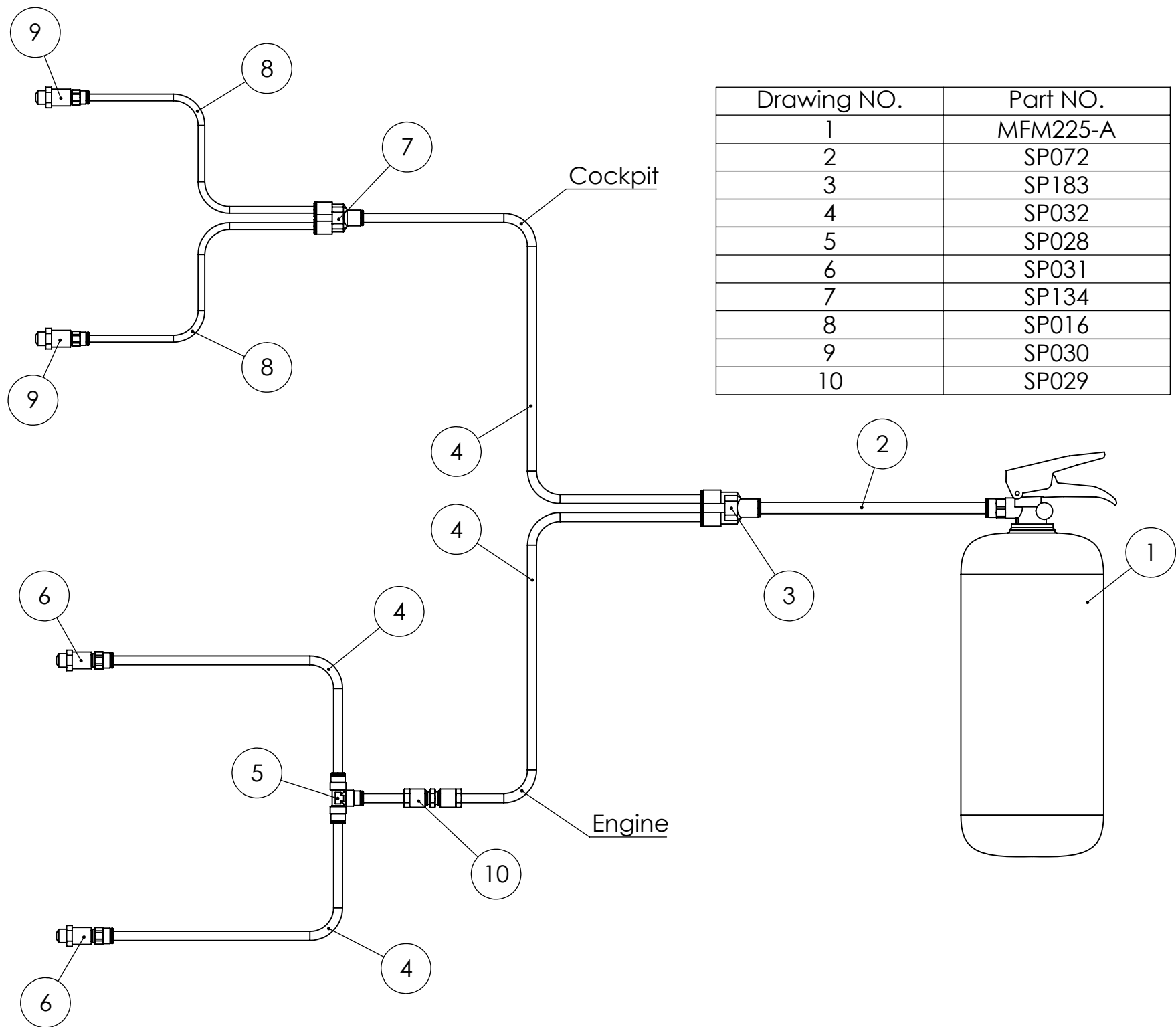

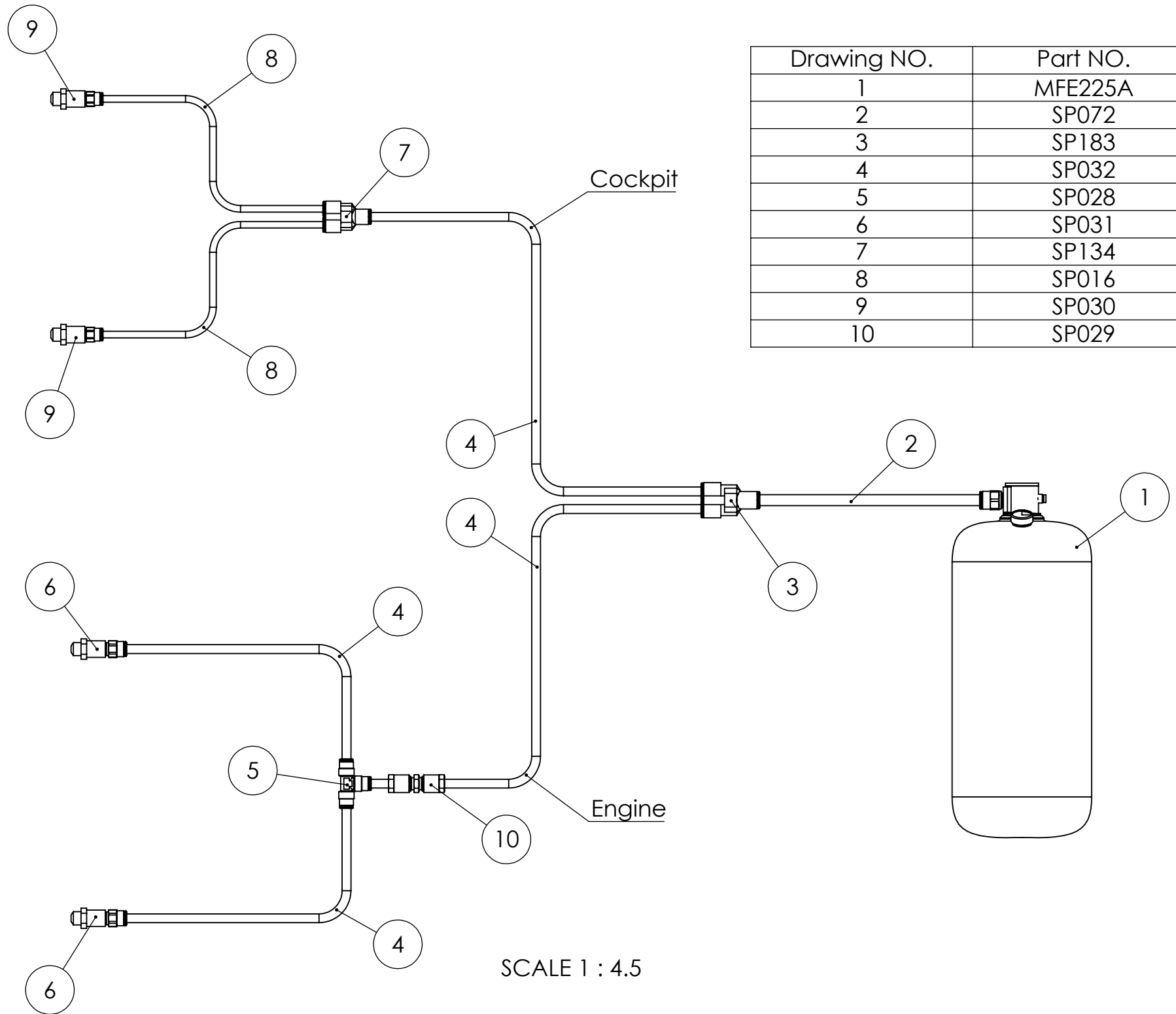

Drawing NO.	Part NO.
1	MFE225A
2	SP072
3	SP183
4	SP032
5	SP028
6	SP031
7	SP134
8	SP016
9	SP030
10	SP029

SCALE 1 : 4.5

SAFETY DATA SHEET FOR AFFF **(Aqueous Film Forming Foam)**

APPLICATION	Autosport industry – including saloon, single seaters and other racing cars.
CONTENTS	Hydral AR 3x3 Low Viscosity AFFF, Water
COMPOSITION	Water, Ethaned ol, Ethylene glycol, Urea, Sod um Monodecylsulfate, Diethylene Glycol Monobutyl Ether, Caprylcapr yl Glucos de
APPEARANCE	Clear Liquid with a hint of blue
pH	Approx. 6.5 – 8.5
BOILING POINT	100°C (initial)
VAPOUR PRESSURE	Approx. 17.6 mm Hg Calc @ 20°C
WATER SOLUBILITY	Miscible
FREEZING POINT	-10°C
PHYSIOLOGICAL PROPERTIES	Non-harmful.

SERVICE AND REFILL AGENTS FOR SPA FIREFIGHTER/FIRESENSE-RESPONSE SYSTEMS.

ATS MOTORSPORT

30 SCHOONGEZICHT RD
BERGBRON
JOHANNESBURG
SOUTH AFRICA
PH : 0027 11 726 6314
FAX : 0027 11 673 5185
E : atsleeke@global.co.za
www. ats-motorsport.co.za

DANIELSON EQUIPEMENT

5 RUE CHAMP MAGNY
58470 MAGNY COURS
FRANCE
PH : 0033 386 212 255
FAX : 0033 386 212 265
E : contact@danielson-equipement.com
www. danielson-equipement.com

R&R LOGISTICS NI LTD

7 CADGER RD
CARRYDUFF
BELFAST
BT8 8AU
Contact: Jonathan Martin / Raymond Moore
PH : 02895 213335
E : jonathan@rr-ni.com
www. raceandrally.com

MURRAY MOTORSPORT

UNIT 20 BEECHLAWN IND COMPLEX
GREENHILLS RD
DUBLIN 12
EIRE
PH : 00353 1 4500555
FAX 00353 1 4500585
E : info@murraymotorsport.ie
www. murraymotorsport.ie

GULFSPORT RACING LLC

UNIT 8
INDUSTRIAL AREA 4
STREET 29
DUBAI, UAE
Contact: Mike Scott
PH : 00971 4 341 5438
FAX: 00971 4 341 5438
E : mike.scott@gulf-sport.com

GIEFFE SRL

VIASAN GIULIANO 39A
15040 CASTELCERIOLO (AL)
ITALY
PH : 0039 0131 216505
FAX : 0039 0131 216506
E : damiano.logiudice@gieffesrl.it
www. gieffesrl.it

KH MOTORSPORT

RAMSASEN
665 91 KIL
SWEDEN
PH : 00465 421040
FAX : 00465 421165
E : kh.msport@swipnet.se
www. khmotorsport.se

ORECA

PARC DACTIVITES DE SIGNES
AVE DE ROME
83870 SIGNES
FRANCE
PH : 0033 494 885 801
FAX : 0033 494 328 001
E : lcourdon@oreca.fr
www. oreca.fr

DES MOORE RALLYING

46 CARRICKADUFF RD
CARNAGH
CO. ARMAGH
BT60 3HZ
PH : 02837 538633
FAX : 02837 539286
E : des@dmrr.net
www. dmrr.net

RECHSTEINER RACING S A

ZONE INDUSTRIELLE DES
PRES MORES
1315 LA SARRAZ
SWITZERLAND
Tel: 0041 21 866 1666
Fax: 0041 21 866 1667
Email: pa.rechsteiner@rechrracing.com
Website: www.rechrracing.com

SERVICE AND REFILL AGENTS FOR SPA FIREFIGHTER/FIRESENSE-RESPONSE SYSTEMS.

BOTH IMPORTS

55 NORTH TERRACE
HACKNEY
SA 5069
AUSTRALIA
PH : 0061 8 8113 0600
FAX : 0061 8836 28811
E : spalite@nttyres.com.au
www. nttyres.com.au

IMPORT PARTS

SEPN 504 BL.C LOJA 34
ED. MARIANA
BRASILIA.DF
BRAZIL
CEP 70. 730 - 523
PH : 0055 61 326 2614
FAX : 0055 61 326 7717
E : ip-parts@uol.com.br
www. ip-part.com

SERVALL INC

GREEN HILL
ST. MICHAEL
BARBADOS
WEST INDIES
PH : 001 246 424 5912
FAX : 001 246 429 4854

MERLIN MAILORDER

THE BRIDGESTONE BUILDING
CASTLE COMBE MOTOR RACING CIRCUIT
NR CHIPPENHAM
WILTSHIRE, SN14 7EX, UK
PH: 01249-782101
FAX: 01249782161

RACER INDUSTRIES

286 SOUTHPORT NERANG ROAD
SOUTHPORT
QUEENSLAND 4215
AUSTRALIA
Tel: 0061 7 5591 8198
Fax: 0061 7 5591 6458
Email: sales@racerindustries.com
Website: www.racerindustries.com.au

NEIL ALLPORT MOTORSPORT

34 OLIVE RD
PENROSE
AUCKLAND
NEW ZEALAND
PH : 00649 579 0113
FAX : 00649 579 0114
E : sales@namSPORT.co.nz
www.namSPORT.co.nz

NOVA ENGINEERING

220 - 1 OHMIKA
OYAMA - CHO
SUNTO - GUN
SHIZUOKA 410 - 1308
JAPAN
PH : 0081 550 780329
FAX : 0081 550 780064
E : nova-eng@mail.wbs.ne.jp

GUNNAR AASKOV MOTORSPORT

CREDITOR 231826
KORNMARKEN 2, GRAVENT
DK-6040 EGTVED.
DENMARK
PH : 0045 75 55 32 90
FAX : 0045 75 55 38 85
E : mail@aaskov-motorsport.dk

SPA TECHNIQUE INC

8225 INDY LANE
INDIANAPOLIS 46214
USA
PH : 001 317 271 4941
FAX : 001 317 271 7951
E : info@spatechnique.com
www.spatechnique.com

MARDI GRAS MOTORSPORT LTD

UNIT 45 SILVERSTONE CIRCUIT
TOWCESTER
NORTHANTS
NN12 8GZ
Tel: 01327 858 006
Fax: 01327 858 800
Email: info@mardigras.co.uk
Website: www.mardigras.co.uk

SERVICE AND REFILL AGENTS FOR SPA FIREFIGHTER/FIRESENSE-RESPONSE SYSTEMS.

ALL FIRE SECURITY

BRANDBEVEILIGING MARLIER
BVBA
ROESELARESTRAAT 180
WEVELGEM 8560
BELGIUM
Tel: 0056 42 32 29
Fax: 0056 42 00 83
Email: info@allfiresecurity.be
Website: www.allfiresecurity.be

H C GROUP

222 SRI WORACHAK BLD NO G8
LUANG ROAD
DOMPRAB, BANGKOK
THAILAND 10100
Tel: 00662 223 1144
Fax: 00662 226 3660
Email: info@hcthailand.com
Website: www.hcthailand.com

MOTORSPORT ASIA

SUITE 22 - 1 LEVEL 22
MENARA PANGLOBAL
NO 8 LORONG P RAMLEE
50250
KUALA LUMPUR
Tel: 00603 2026 1680
Fax: 00603 2026 1681
Email: mal@motorsportasia.com
Website: www.afos.com

SPEEDMASTER

7 HAREFIELD CLOSE
NORTH EPPING
NEW SOUTH WALES 2121
AUSTRALIA
Contact: Tony Dunn
TEL: (02) 9868 5899
Mob: 0404 007 768
Email: tony@speedmaster.net.au

MTEC FORMULA TECHNOLOGY

MAKELA RACING TEAM
URHEILUTE 4
RANTSILA 92500
FINLAND
Contact: Miikka Makela
TEL +358 (0) 40 867 8197
Email: miikka@makelracing.fi

THE CROSSLE CAR COMPANY LIMITED

RORY'S WOOD
OLD HOLYWOOD ROAD
HOLYWOOD
CO DOWN
BT18 9QS
Tel: 0044 (0) 28 9076 3332
Fax: 0044 (0) 28 9076 0676
Email: arnie@crossle.fsnet.co.uk
Website: www.crossle.co.uk

OSATUONTI RACING SHOP

PUROKATU 9
21200 RAISIO
FINLAND
Tel: 00358 500 525342
Email: myynti@osatuontiracingshop.fi
Website: www.osatuontiracingshop.fi

PERFORMANCE RACEGEAR

246 GREAT EASTERN HWY
ASCOT WA 6104
AUSTRALIA
Contact: Mike Nairn
TEL: (08) 6461 6919
Mob: 0424036418
Email: mike@performanceracegear.com.au

AUTOSLANGER

RANTZAUSGAVEVEJ 5
8355 SOLBJERG
DENMARK
Contact: Benjamin Muusmann
PH: +45 228678790
E: benjamin@autoslanger.dk

REVOLUTION RACEGEAR

592 WHITEHORSE ROAD
MITCHAM
VICTORIA 3132
AUSTRALIA
Contact: Tullio Salta
Tel: 03 9873 8700
Fax: 03 9873 8711
Email: tullios@racegear.com.au
Web: www.revolutionracegear.com.au

**SERVICE AND REFILL AGENTS FOR
SPA FIREFIGHTER/FIRESENSE-RESPONSE
SYSTEMS.**

COMPLETE FIRE & SAFETY

43 ALLARDICE STREET
STONEHAVEN
ABERDEEN, AB39 2AB
SCOTLAND
Contact: Garrith Glennie
Tel: 01224 911 148
Mob: 07518 339528
Email: garrith@firesafety247.co.uk

**BERNICO INTERNATIONAL
RACING**

VICTOR DUMONLAAN 6
2830 WILLEBROEK
ANTWERP
BELGIUM
Contact: Raf Van Belle
Tel: +32 34558728
Fax: +32 34550088
Email: magazijn@bernico.be



The Mill House, Tamworth Road, Packington Hayes
Nr Lichfield, Staffordshire, England WS14 9PN

Tel: 01543 434580 Fax: 01543 434581

E-mail: sales@spa-uk.co.uk

Web Site: www.spa-uk.co.uk