



FEDERATION INTERNATIONALE DE L'AUTOMOBILE

Homologation N°

CS.024.2025

Date

21.07.2025

FICHE DE PRESENTATION POUR SIEGE DE COMPETITION (NORME FIA 8855-2021)
PRESENTATION FORM FOR COMPETITION SEAT (FIA STANDARD 8855-2021)

1. GENERALITES / GENERAL

101. FABRICANT / MANUFACTURER

SPARCO S.P.A.

a) Adresse
Address

VIA LEINI 524 – 10088 VOLPIANO (TO) – ITALY

b) Téléphone
Phone

+39 011 22.40.911

c) E-mail
Email

INFO@SPARCO.IT

102. PHOTO DU SIEGE AVEC LES SUPPORTS ¾ AVANT / PHOTO OF THE SEAT WITH SEAT BRACKETS ¾ FRONT

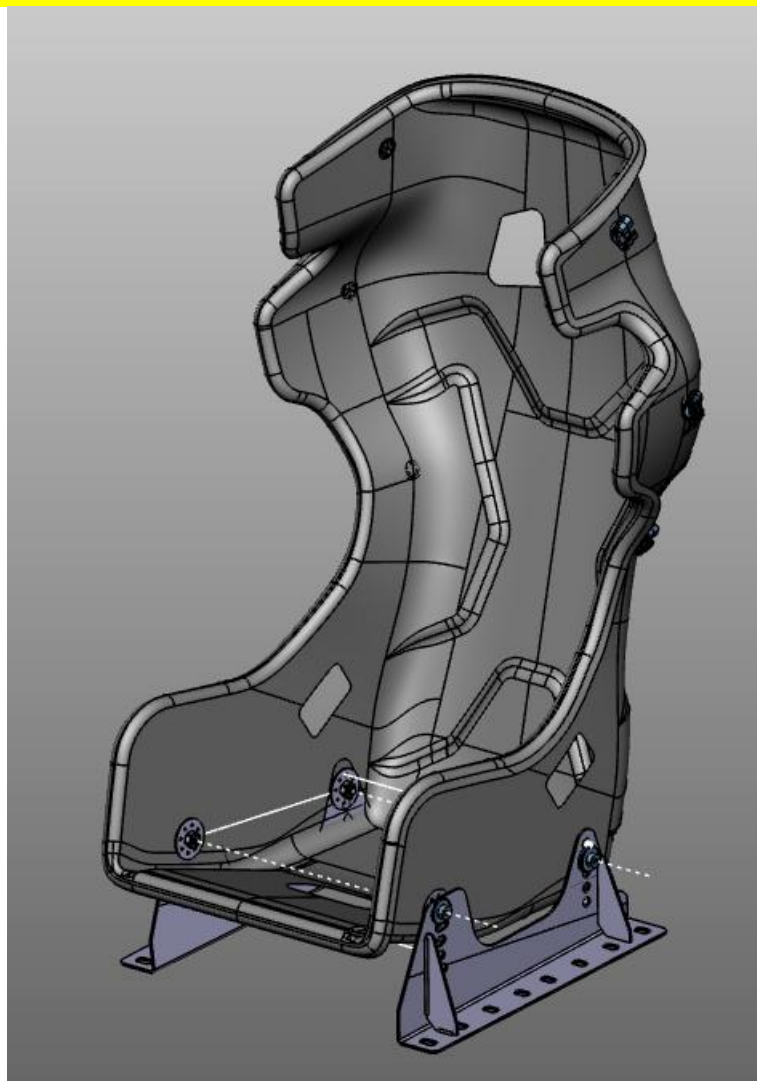

103. MODELE / MODEL

- | | | |
|---|--|---|
| a) Modèle du siège
<i>Seat model</i> | MASTER ADVANCE | |
| b) Fixation
<i>Attachment</i> | Siège 4 points / <i>4-point seat</i> <input checked="" type="checkbox"/> | Siège 6 points / <i>6-point seat</i> <input type="checkbox"/> |
| c) Référence du support de siège au plancher
<i>Floor seat bracket reference</i> | 004926 | |
| d) Matériau du support de siège au plancher
<i>Floor seat bracket material</i> | STEEL | |
| e) Référence du support du dossier
<i>Seat back bracket reference</i> | | |
| f) Matériau du support du dossier
<i>Seat back bracket material</i> | | |
| g) Poids du siège
<i>Weight of the seat</i> | 10KG | |

**104. DESSIN D'ASSEMBLAGE DE LA FIXATION DES SUPPORTS SIEGE-SIEGE (VUE ECLATEE) /
ASSEMBLY DRAWING OF THE SEAT-SEAT BRACKETS FIXATION (EXPLODED VIEW)**

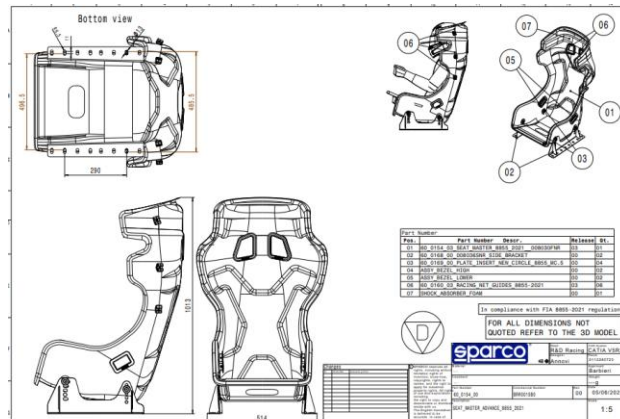

2. DETAILS DU SIEGE / DETAILS OF THE SEAT

201. VUES / VIEWS

A1) Vue de face / *Front view*

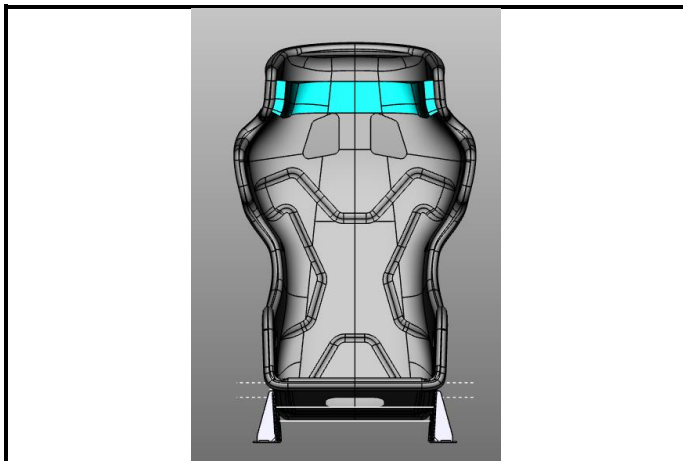

A2) Vue de derrière / *Rear view*

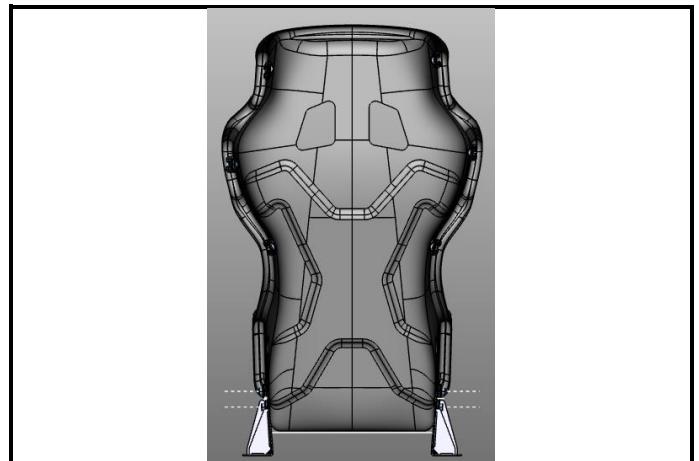

A3) Vue du côté gauche / *Left side view*

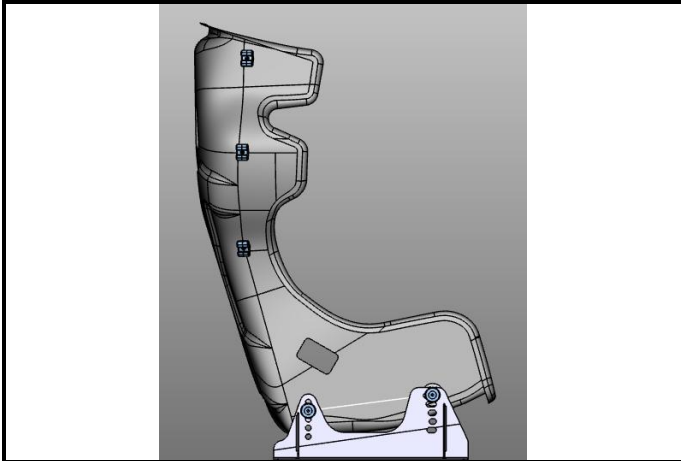

A4) Vue de haut / *Top view*

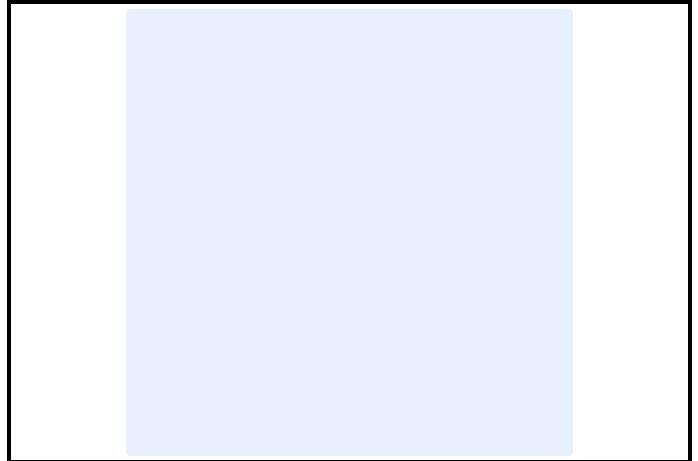

A5) Protection des bords des ouvertures - bassin / *Slot edge cover-pelvis*

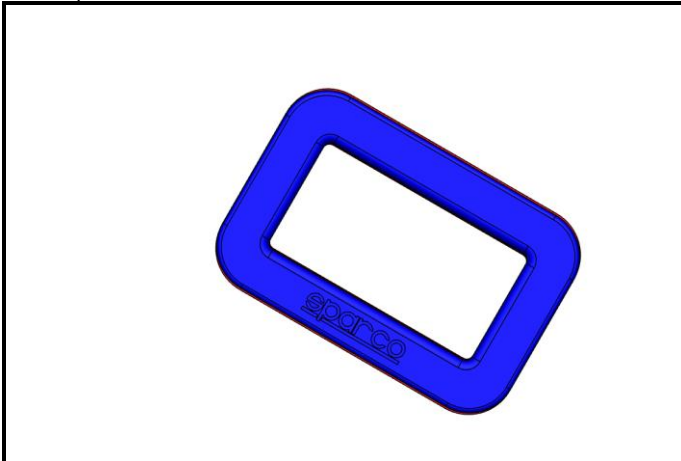

A6) Protection des bords des ouvertures - épaule / *Slot edge cover-shoulder*



A7) Protection des bords des ouvertures - entrejambe / *Slot edge cover-crotch*

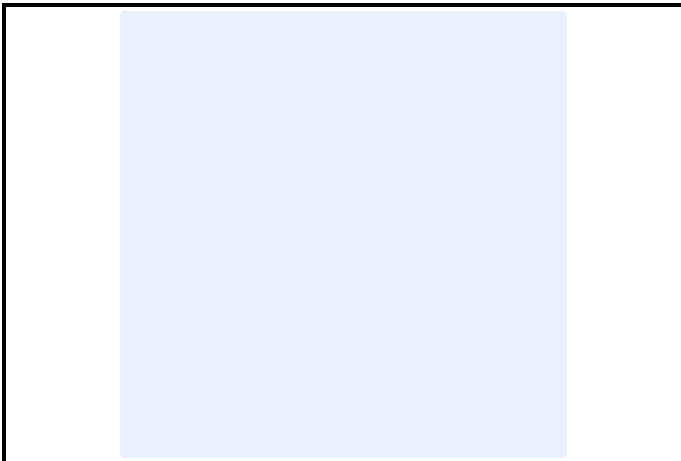

A8) Guides pour filets de course / *Racing nets guides*

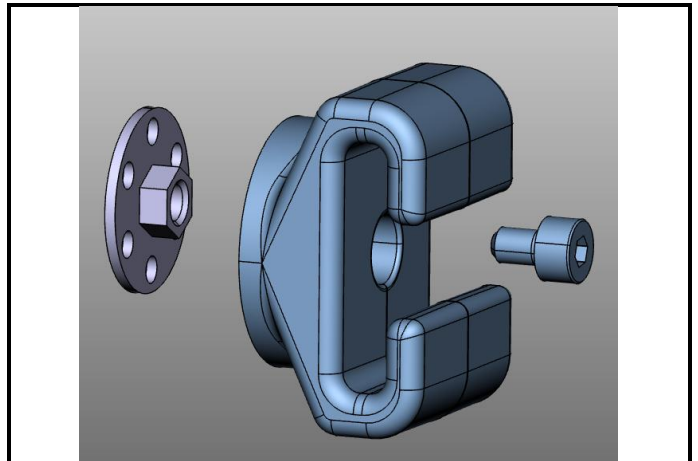

3. DETAILS DES SUPPORTS DE SIEGE / DETAILS OF THE SEAT BRACKETS

301. VUES / VIEWS

B1) Dessin technique / Technical drawing

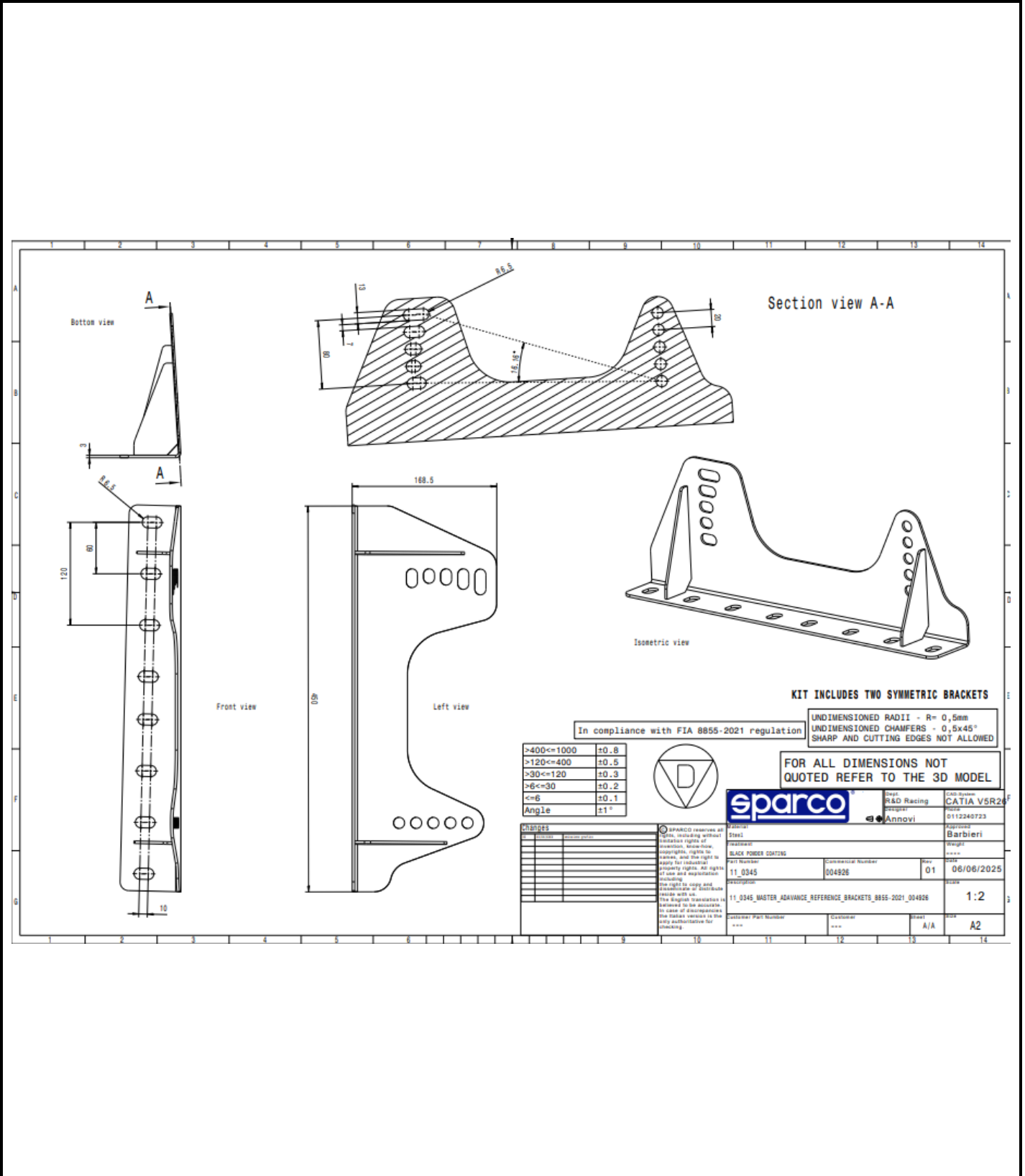

**4. ETIQUETTES D'HOMOLOGATION DU SIEGE ET DES SUPPORTS DE SIEGE / SEAT AND SEAT BRACKETS
HOMOLOGATION LABELS**

401. ETIQUETTES / LABELS

	Etiquette d'homologation sur le siège <i>Homologation label on the seat</i>	Etiquette d'homologation sur le support de siège <i>Homologation label on the seat bracket</i>
a) Dimensions [mm] <i>Dimensions [mm]</i>	34 x 84	34 x 84

1) Etiquette d'homologation et autocollant FIA collés sur le siège
Homologation label and FIA sticker glued on the seat

2) Etiquette d'homologation sur le support de siège
Homologation label on the seat bracket

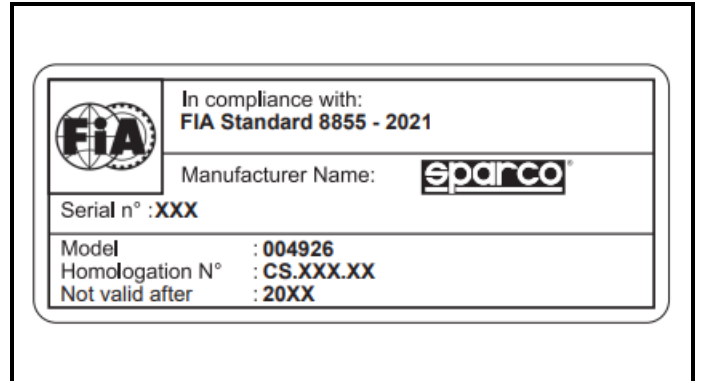
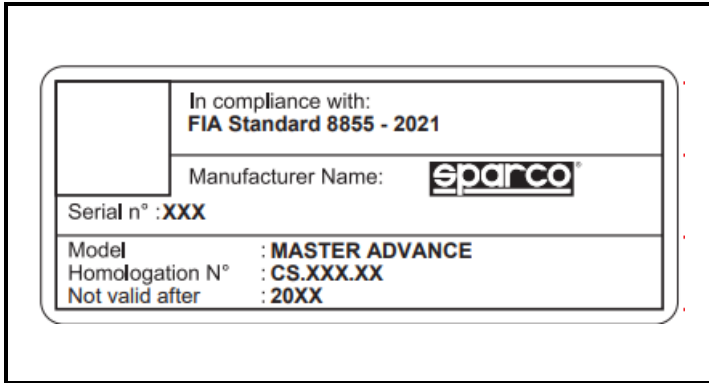

5. SUPPORTS DE SIEGE ALTERNATIFS / ALTERNATIVE SEAT BRACKETS

501. MODELE / MODEL

- | | |
|---|--|
| a) Référence du support de siège au plancher
<i>Floor seat bracket reference</i> | BAA0385B0 CO DRIVER LH / BAA0385B0 CO DRIVER RH |
| b) Matériau du support de siège au plancher
<i>Floor seat bracket material</i> | DOMEX 700 MC |
| c) Référence du support du dossier
<i>Seat back bracket reference</i> | N/A |
| d) Matériau du support du dossier
<i>Seat back bracket material</i> | N/A |

502. VUES / VIEWS

D1) Dessin technique / *Technical drawing*

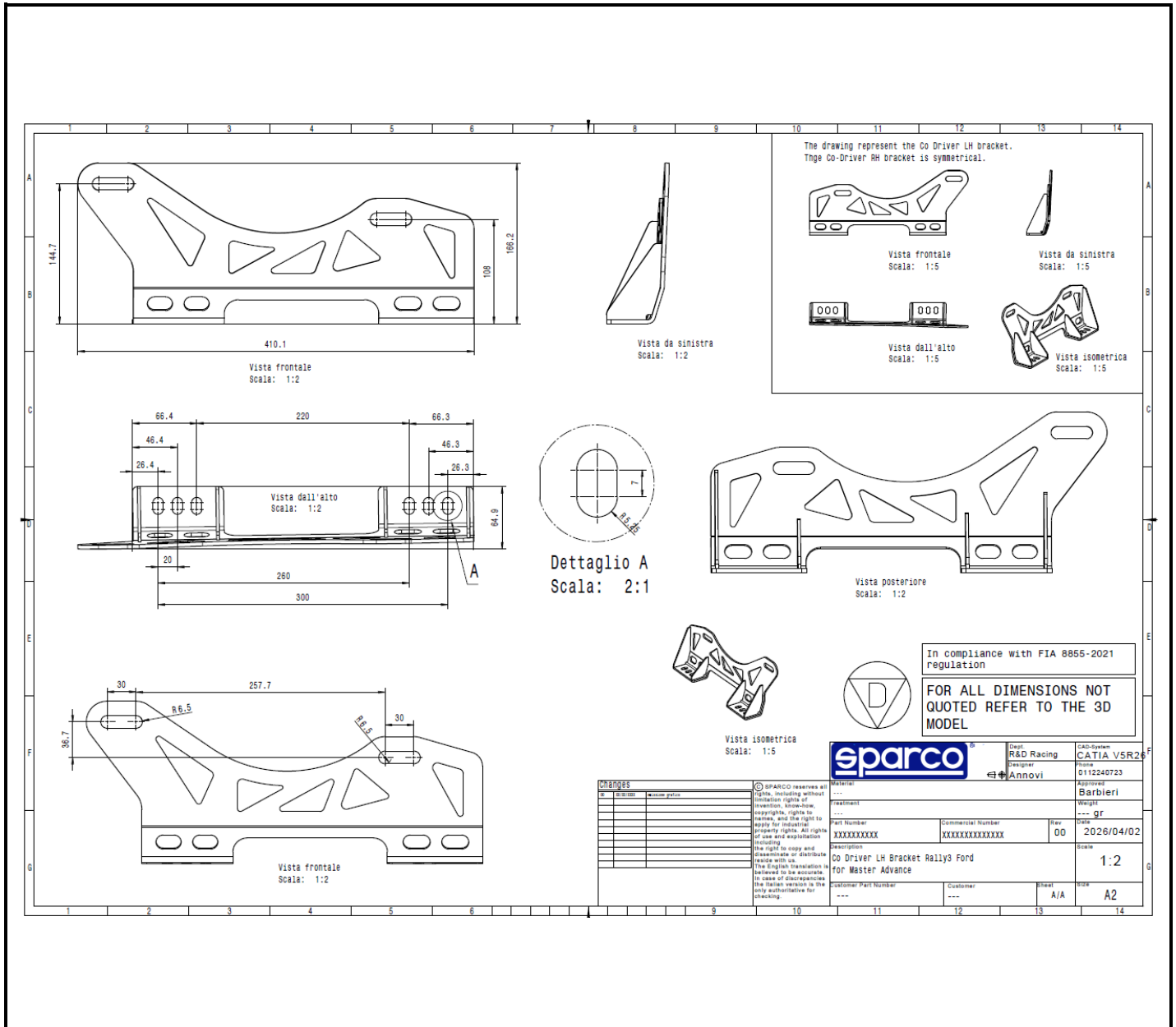

Marque
Make

SPARCO

Modèle
Model

MASTER ADVANCE

Homologation N°

CS.024.2025

