



FEDERATION
INTERNATIONALE
DE L'AUTOMOBILE
WWW.FIA.COM

2018 FIA WTCR Technical Regulations

ART. 1	GENERAL REMARKS
	<p>Article 1 of the WSC TCR Technical Regulations applies. Unless otherwise stated, Articles 251, 252 and 253 of the FIA Appendix J are applicable, but the articles set out in the present regulations and the FIA Technical Passport have predominance. Articles 255 and 263 of the FIA Appendix J are also occasionally referred to. All modifications which are not explicitly allowed by the present regulations are forbidden. An authorised modification may not entail a non-authorised modification.</p>
ART. 2	DEFINITION
2.1	<p>Bodywork</p> <p>See App. J; Art. 251.2.5.2 Any air intake is considered to be part of the bodywork.</p>
2.2	<p>Chassis (Body shell)</p> <p>The main body of the car into which is fitted the engine, transmission, running gear, electrical systems, seats, controls, bodywork, etc.</p>
2.3	<p>Production (part)</p> <p>As fitted to the basic mass production car; the proof rests with the competitors.</p>
2.4	<p>Original</p> <p>As fitted to the WSC -certified car and in compliance with the TCR Technical Form.</p>
2.5	<p>Minimum Weight</p> <p>is the weight of the car without driver, with empty tanks of consumable fluids (fuel, wind screen wash & drinking water, etc.) and with all other tanks filled at the working level.</p>
2.6	<p>Minimum Racing Weight</p> <p>is the minimum weight of the car with the driver with full compulsory equipment (Appendix L) imposed to be respected at any time during the competition. The minimum racing weight can vary following decisions for BoP and the Success Ballast allocation. The minimum racing weight doesn't include the non-compulsory equipment.</p>
2.7	<p>Cockpit</p> <p>The interior volume of the main structure which is reserved for the occupants. Its limits are defined by the roof, the floor, the doors, the lateral parts, the glazed parts and the front and rear bulkheads (or the back plane of the rear seats).</p>
2.8	<p>Turbo Charging</p> <p>Increasing the mass of the charge of the fuel/air mixture in the combustion chamber (over the weight induced by normal atmospheric pressure, ram effect and dynamic effects in the intake and/or exhaust system) using a turbo charger.</p>
2.9	<p>Location</p> <p>A site defined relative to the production: centre line of the car, axles centre (middle of the wheelbase on the centre line), cockpit, luggage compartment and engine compartment.</p>
2.10	<p>Position</p> <p>The site defined by dimensions from the production car data, e.g. axles centre and centre line of the car. For position evaluation will be used a tolerance of $\pm 5\text{mm}$.</p>
2.11	<p>Telemetry</p> <p>The transmission of data between a moving car and the pit or to anyone connected with the entry of that car.</p>
2.12	<p>Mass Production</p> <p>The Minimum Production requested for eligibility of car models and parts coming from other cars like engine, turbocharger, water cooler, intercooler, etc. is 5000 pieces / 12 consecutive months.</p>

2.13	<p>Model of car</p> <p>All the identical cars belonging to a family (see below) and to a production series distinguishable by an identical conception and identical external general lines of the bodywork, and by an identical mechanical conception of the engine and the transmission to the wheels.</p>
2.14	<p>Family of car</p> <p>Different series models belonging to one and the same production series of the same manufacturer.</p>
2.15	<p>Certification</p> <p>The FIA Technical Passport is the official documentation of WTCR Cars certified by the FIA. The Technical Form may have Extensions: Variant Option (VO), Supply Variant (VF) and Erratum (ER).</p>
2.16	<p>OEM (Original Equipment Manufacturer)</p> <p>OEM is a manufacturer of the mass produced cars and the supplier of the original spare parts.</p>
2.17	<p>Reference Part, Component or Unit</p> <p>Certificated part, electronic control unit or aggregate registered with the FIA, which are deposited with the technical delegate and can be installed in the race cars on his decision at any time of the competition.</p>
2.18	<p>OEM Part</p> <p>Component coming from any OEM mass produced car and in normal sale.</p>
2.19	<p>FIA Technical Passport</p> <p>Unique document issued by the FIA to single WTCR cars that:</p> <ul style="list-style-type: none"> - features all the relevant technical information of a model of car according to the present technical regulations - identifies a single car uniquely by its manufacturer's chassis number and an FIA identification number
ART. 3	REGULATIONS
3.1	<p>Eligible cars</p> <p>Eligibility criteria for WTCR cars:</p> <p>Each WTCR car must be the subject of an FIA Technical Passport. The FIA Technical Passport must be applied for by the competitor entered in the FIA WTCR World Touring Car Cup to the FIA Technical Department, provided that the model requested is already certified by WSC and has a valid TCR Technical Form. The FIA will require a technical inspection in order to create the FIA Technical Passport. The date and venue of the technical inspection is at the FIA's discretion. The competitor may be assisted by the manufacturer or authorized tuner.</p> <p>In order to obtain the FIA Technical Passport, competitors must previously be:</p> <ul style="list-style-type: none"> - formally entered in the FIA WTCR World Touring Car Cup. - in possession of the TCR Technical Form of their car. <p>The FIA Technical Passport will be valid only for the year of the present regulations.</p>
3.2	<p>Compliance with the regulations</p> <p>All vehicles must be conformed to these regulations, FIA Technical Passport and to all FIA Notification and Technical Bulletins.</p> <p>All parts not mentioned in these regulations have to remain those from the basic production car or another production model of the same manufacturer and correspond to the Manufacturer's Parts Catalogue for the produced model and may not be modified in any way.</p> <p>In case of doubt about the conformity of any part, the Technical Delegate may ask the replacement with a reference part without any further explanation. All cost of such operations will be covered by the Competitor.</p> <p>Teams will deliver on request to the FIA technical staff the following information regarding cars:</p> <ul style="list-style-type: none"> - Data from team's data logger - Video footage from team's camera - Any other technical documentation <p>Upon request, manufacturers will deliver to the FIA technical staff any technical information regarding the cars.</p> <p>FIA and WSC have the right to archive all information regarding WTCR cars.</p> <p>It is the duty of each competitor to assure the Scrutineers and the Stewards of the competition that his car complies with these regulations in their entirety at all times during a competition.</p> <p>A car, the construction of which is deemed to be dangerous, may be excluded by the Stewards.</p>

3.3**Measurements**

All cars' measurements must be taken while the car is stationary on a flat horizontal surface in the location stated in the Sporting or in the Supplementary Regulations.

3.4**Material**

Titanium or magnesium alloys, ceramic or exotic materials and sophisticated coatings are not permitted unless used for the production part or explicitly authorised by these regulations.

All flexible supports (engine, transmission, sub frames, etc.) may be replaced by stiffer brackets with same functional dimensions. If not otherwise defined by the present regulations the aggregate's position may not be modified. (Certification)

External bodywork parts may be repaired by adding material respecting the certified properties (minimum weight, functional shape, etc.). Such operation needs the approval of the technical delegate.

3.5**Data logging**

The car must be fitted with a scrutineering data logging system () providing the following data:

- Speed of the 4 wheels
- Engine revs
- Longitudinal acceleration
- Lateral acceleration
- Throttle pedal position
- Throttle valve position and of any other control element
- Engine load target & delivered engine load (if the Throttle Valve doesn't follow the Throttle Pedal Position)
- Engine Water Temperature
- Inlet air temperature in the manifold
- Boost pressure (monitored by an additional sensor)
- Front & Rear Brake Calliper pressure
- Lap trigger
- Lambda-signal
- Ignition angle timing
- Injection duration, start & end
- Variable timing positions
- GPS
- Steering wheel angle
- Launch-control button

The Scrutineering Data Logger complete system as defined per the FIA Technical Passport must be installed and operated according to the supplier instructions.

The collected data remain at FIA/WSC disposal.

The use of a Team Data Logger is allowed. The Team will allow access to the Technical Delegate to the data of the Team Data Logger at any time.

The scrutineering data logger may not be used as Team Data Logger and may not be accessed by the team.

3.6**Telemetry**

The use of telemetry is forbidden.

3.7**Driving aids**

Driving aids are not permitted unless featuring in the FIA Technical Passport.

If the race car using mass production engine management cannot be operated without the Driving Aids, the mass production systems including mechanical parts and Electronic Control Units [Anti-lock Braking System (ABS), Electronic Stability Program (ESP) & Traction Control System (TCS) not included] may be used on condition that the original hardware and software are maintained (only changes to the wiring are permitted). It is not allowed to the driver sitting in the car to change settings. The systems may be also switched off or removed.

The pit speed limiter and the launch control (as described below) are permitted. For the launch control 1 (one) additional engine rev-limiter is allowed. The rev-limiter is activated and stopped by the driver and is constant during the launch control phase. There is no closed loop control considering engine revs, wheel speed and clutch actuation allowed.

Other constant rev-limiter(s) is (are) permitted for imposed speed limits (pit speed, virtual safety car, circuit sections with speed limit, etc.).

3.8**Balance of Performance (BoP)**

All Manufacturers must communicate the requested specific car data for the definition of the numeric model for the BoP evaluation.

Parameters which may be modified for BoP at any time of the season:

- Minimum Racing Weight; max. penalty 50kg; max. weight reduction 30kg
- Engine performance level implemented by monitored electronic components (100%, 95% and 90%)
- Smaller boost pressure steps implemented between the aforementioned mentioned Engine performance levels
- Minimum Ride Height

FIA/WSC reserves the right to take further measures in order to guarantee proper BOP.

3.9 Presentation of and modifications to the FIA Technical Passport

Each Competitor must have at the scrutineering the stamped and signed original FIA Technical Passport for each car.

Technical Form's modification will be allowed during the season only for following reasons:

- Safety
- Reliability

ART. 4 BODYWORK

4.1 Chassis (Certification)

The chassis cannot be modified unless permitted by the present regulations.

All chassis modifications including the removal of unused supports have to be certified in the Technical Form.

Following condition must be respected:

- Width of bodywork: Maximum 1950mm
- All chassis modifications have to be approved.
- If not otherwise defined by the present regulations any non-movable element must be attached with the use of tools.
- Wheel arch modifications allowed, for the sole purpose to accommodate race tyres.
- Front bulkhead may not be modified except for a modified passage of the gearshift control, electrical loom(s), brake lines, fuel lines and extinguisher lines.
- No modification of McPherson turrets except of local reinforcement following the original shape and through metal ribs or fins as connection between turrets and front bulkhead for strengthening of strut mounting area. Production reinforcements and openings may be locally reworked without weakening the structure to allow access to the strut.
- Seam welding replacing or reinforcing production part spot welding is authorized.
- Local modifications of the chassis or sub frames are permitted to provide clearance to the exhaust system, transmission and suspension.
- Temporarily removal of the roof outer skin is permitted only to allow the safety cage's correct installation.

Sub frames may not be modified for the fixation on the body shell or for the attachment of suspension elements. All sub frame modifications have to be approved. Reinforcements and the removal of unused supports are permitted.

Strengthening of the suspended parts of the chassis / body shell through the addition of parts and/or material is allowed under the following conditions:

The shape of the reinforcing part/material must follow the surface of the part to be reinforced, having a shape similar to it and the following maximum thickness, measured from the surface of the original part :

- 4 mm for steel parts.
- 12 mm for aluminium alloy parts.

Stiffening ribs are allowed but the making of hollow sections is forbidden.

The reinforcing part/material must not have any other function than that of reinforcement.

Passage for the gearshift control: Local modifications are authorised.

Mountings and bearings of antiroll bars: The main rails may be modified to integrate the anti-roll bar bearings. The new mountings of the anti-roll bars must not have any other function.

Mounting of pedal box and master cylinders: Modifications are authorised provided they have no other function than to allow the fixing of the master cylinders and/or the pedal box.

Central tunnel and/or floor on the driver's side to allow Driver's seat installation for correct driver's position:

Local modifications to the central tunnel and/or the floor on the driver's side are authorised with no other purpose than correctly installing the compulsory racing seat according to this regulation.

Panel on top of fuel tank area for Fuel tank ancillaries' installation: Local modifications of the area situated on top of the fuel tank are authorised with no other purpose than creating a flat surface to install fuel tank ancillaries.

4.1.1 Bonnet and boot lids

It must be possible to open them without use of tools.

The retaining springs (not the hinges) may be removed, but the car must have supports to hold the bonnet and the boot lid in open position.

Openings in the engine bay bonnet are allowed up to a maximum total surface of 1050cm², including any original opening(s) but must be covered by wire netting with maximum mesh surface of 500mm². Trims on the openings can be added to the bonnet provided that they do not protrude from the outer surface more than 15mm outwards and 50mm inwards.

Cut-outs in the original production bonnet for the trims are allowed up to a total surface of maximum 2350cm² including any original cut outs. The production internal reinforcements may be removed in the opening zone.

4.1.2**Doors**

The production door locks, door-hinges, anti-intrusion bars, external door handles, and the driver side window lifters stay as original and in operation.

It must be possible to open all doors from outside (original handles) and the front doors also from the inside.

Controls for opening the rear doors from the inside may be removed.

The other side window lifters may be removed, but the side windows must be locked in place and secured from all movement.

The removal of door soundproofing material and decorative strips is allowed.

Original inner trim panels must be replaced and be made from plastics (including composite materials) at least 1mm thick.

The panels must totally cover the door, its handles, locks and window winding mechanisms.

Air inlets for driver cooling in the area of the external mirrors are accepted.

4.1.3**Engine & Luggage Compartments**

The soundproofing, decorative, insulating material and parts may be removed.

4.2**Windscreen and windows**

The use of the mass production windscreen is permitted.

The use of electric heated glass windscreen of artisanal production is allowed.

Plastic windscreen (polycarbonate or PMMA ensuring the same transparency as the original glass) with the same shape of the reference part, with or without heating with minimum thickness 5.85mm is allowed..

Anti-intrusion arm(s) or support(s) for Plastic Windscreen may be used.

The addition of a maximum of 4 protective transparent films on its external face is permitted.

Plastic rear window min. 3.85mm is allowed.

The internal face of side and rear glass windows as well as that of glass rear-view mirrors must be covered with a transparent and colourless plastic safety film with a maximum thickness of 0.1mm in order to avoid the shattering and spraying of glass in the event of an accident. It must be fitted in a manner that facilitates checking.

4.3**Exterior****Bodywork - General**

A maximum of 3 holes (maximum diameter of 12.5 mm) are permitted in order to use supplementary measuring devices (radio, temperature, pressure, and similar).

If a device is not used during a competition, the corresponding hole must be sealed off and the exterior of the bodywork must retain its original appearance.

The only body parts that can be replaced and changed in shape are:

- Front bumper; Shape resemble the original must be approved prior to production; no dive planes allowed.
- Front fenders' lower edge behind the wheel may not be higher than front door's bottom border. Shape must be approved prior to production (no louvres allowed)
- Side sills (these may be added if not present in the production car)
- Rear wheel arch extensions
- Rear door bulge compatible with the rear arch extensions
- Rear bumper; Shape resemble the original must be approved prior to production
- Wheel arch liners

No flat floor behind the vertical plane tangent to the back side of the front wheels and the foremost point of the rear bumper. Engine bay protection panel between the frame rails are permitted.

It is not allowed to tape the joints between bodywork panels. The hood's and boot lid's original position may not be changed.

Installation of air jacks

The bodywork may be modified over a maximum area of 100 cm² to create housing for the air jack connector.

The connector for the feeding of compressed air must be situated rearward of the rear axle centreline and must not protrude beyond the surface of the bodywork.

Roof Hatch installation without structural parts' modification for access to the cockpit is permitted.

4.4

Aerodynamic devices

Rear wing with brackets

The original car's devices must be removed and must be replaced with one compulsory rear wing made up of:

- One aluminium extruded wing profile (WSC delivery corresponding to the profile defined below)
- Specific part produced following exactly the WSC rear wing dimensions
 - Material: to be defined
 - production drawings will be delivered for certification
 - scrutineering jigs will be delivered on request

Rear wing definition & Dimensions:

- Straight, adjustable, single piece with no flap
- Type BE 183-176 +/- 0.5mm
- Chord = 250 +/- 1 mm
- Width = 1380 +0/-1 mm
- Trailing edge thickness = 2mm +/- 0.5 mm

Be 183-176																	Ro = 2.69	Xo = 2.69	-Yo = 2.79
x %	0	1.25	2.5	5	7.5	10	15	20	30	40	50	60	70	80	90	95	100		
-Yv	2.79	0.53	0.07	0.1	0.62	1.32	2.86	4.35	6.79	8.8	10.02	11.4	11.95	11.8	9.03	5.58	0.1		
-Yo	2.79	7.31	9.4	12.52	14.95	16.94	20.05	22.3	25.01	25.98	25.65	24.39	21.44	17.43	11.43	6.63	0.2		

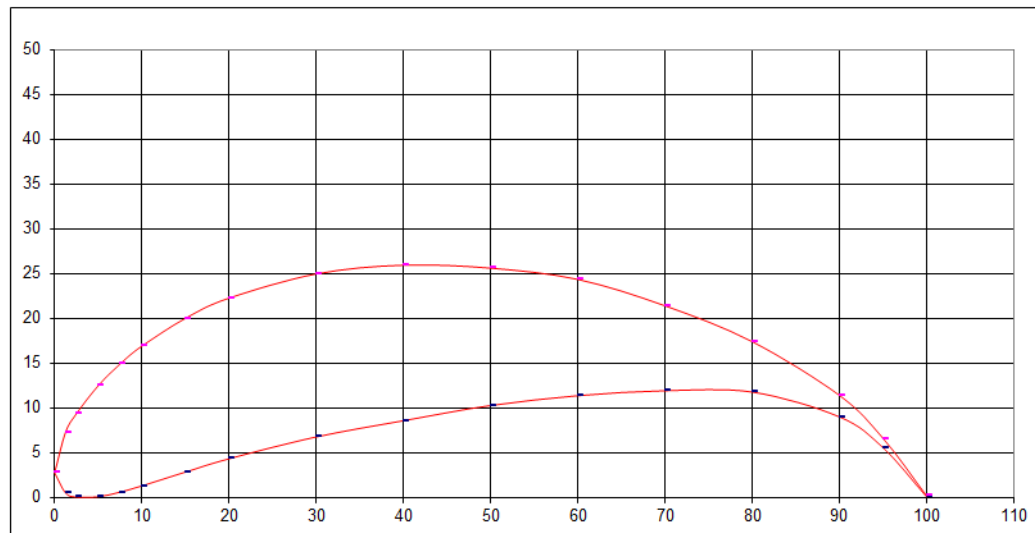

- 2 Brackets

Dismountable, flat, plane surface perpendicular to wing profile surface.

Mounted on the boot lid or on the rear window and to the lower or to the upper wing profile surface.

Min. transversal distance between both supports and between supports and side plates = 100mm.

The leading edge must be rounded with a constant radius.

The trailing edge may be chamfered to a max. of 20 mm (min. thickness at the trailing edge = 2 mm).

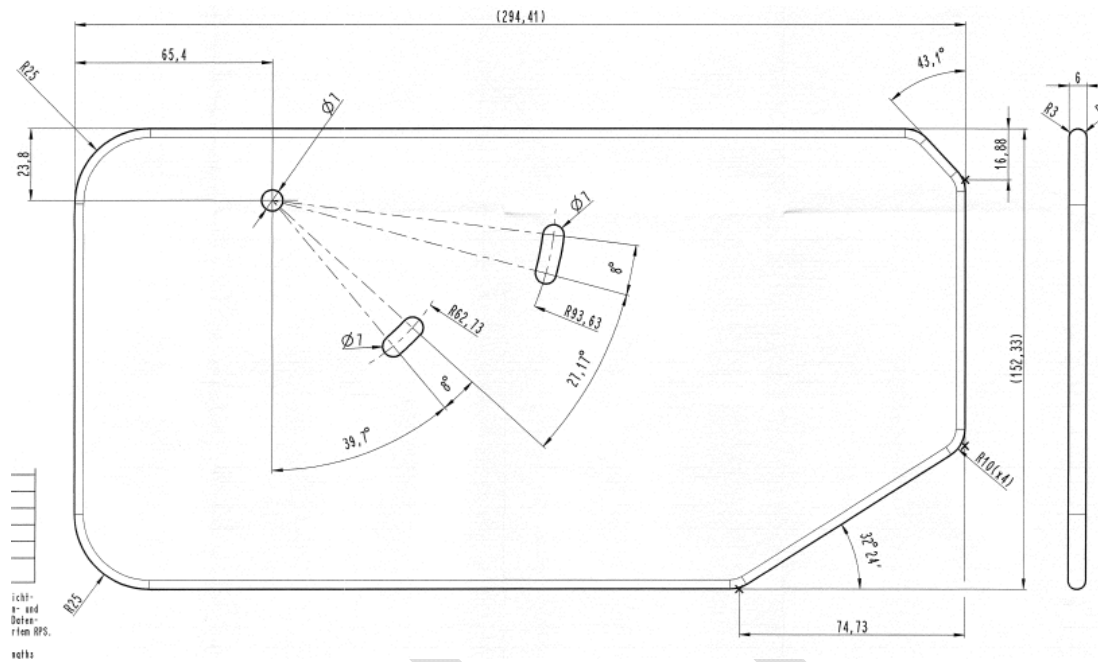

- 2 side plates; All edges will be rounded with at least R3mm
- Dismountable, flat, continuous surface perpendicular to profile centreline.
- Side plates may rotate with respect to the wing profile.
- This device must be rigid and offer no possibility for the penetration of air (groove, hole, opening, etc.).
- Material: to be defined

No element of the rear wing may be located beyond the following limits:

- X = 1050 mm from rear axle centreline.
- Z = Highest point of roof.

The front splitter:

- Specific part produced following exactly the WSC front splitter's dimensions (length, wideness and angles, front overhang, vertical projection, vertical flange's position, sections of areas licked by the airstream)
 - lateral prolongation in "x" for cars with bigger front OH is allowed (max. 50mm in "y")
 - production drawings will be delivered for certification
 - scrutineering jigs will be delivered on request

The foremost edge of the front splitter at $y=0$ will protrude the bumper contour by max. 35mm in vertical projection.

Front Splitter Brackets' design is free.

Adaptation of the WSC front splitter is possible by keeping the effective shape. It will also be possible to reduce the front splitter's protrusion into the wheel arch in case of collision with the front tire's enveloping curve. If adaptation is not possible a new part with similar external shape may be used. (WSC approval and Certification)

Rear diffuser included in the rear bumper:

- One single plane between a vertical plan minimum 380mm behind the rear axle centre line and the bumper's vertical projection
- Hollow area for the exhaust end pipe(s) allowed
- Maximal width: 1650mm
- Max inclination to the doors' lower edge: 25°
- No air circulation over the diffuser

Mass production flexible skirts reducing the ground clearance may be removed. The ground clearance check will consider these parts as bodywork

4.5

Interior

Dashboard trims; Centre console

Trims situated below the dashboard and which are not parts of it may be removed. It is permitted to remove the part of the centre console.

Dashboard

- General shape, appearance, mounting points and position must remain similar to production part.
- Thermoplastic or Fibre Glass plastic materials are free.
- Minimum weight: 2kg including ducting and fixation elements.

Instruments

Display and indicators can be freely fixed on the dash board or to the steering column. The installation shall not interfere with the driver's vision or safety.

Switches

Standard switches may be replaced by switches of different design (robust and reliable) and may be fitted at different locations on the dashboard or on the centre console. Any opening resulting from this must be covered.

Production Pedal Box: metallic pedals may replace the production plastic parts. New master cylinders and new arrangement in the engine bay may be used.

Commercial catalogue pedal box (hanging or floor mounted) and master cylinders in the cockpit: Modifications are authorised provided they have no other function than to allow the fixing of the master cylinders and/or the pedal box

ART. 5 WEIGHT**5.1 Minimum Racing Weight**

The minimum front axle load proportion is 59% to be respected in any conditions during the event.

The Minimum Racing Weight will not include non-compulsory items like driver cooling, team camera, radio, etc.

5.2 Ballast, Success Ballast

Ballast, including success ballast, must be made from metallic plates or blocks and must be fixed in the cockpit and/or in the boot. It is permitted to complete the weight of the car with ballast.

The metallic blocks or plates must be fixed by means of tools, with the possibility of affixing seals.

The ballast must be attached to the body shell/chassis with bolts of at least 8.8-class with a minimum diameter of 8 mm, with counter plates, according to the principle of the following Drawing.

The minimum area of contact between body shell /chassis and counter plate is 40cm² for each fixing point.

Any movable ballast system is forbidden.

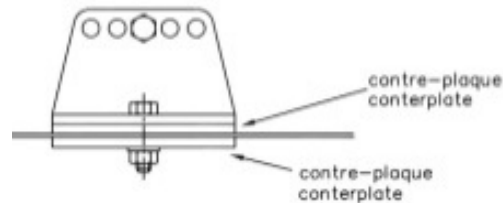

The ballast and success ballast will be declared as such at the scrutineering. The success ballast must be marked and it must be possible to remove separately.

The ballast fixing system must allow to the Technical Delegate to seal the bolts. The ballast must be designed such, that tools are required for its removal.

5.3 Liquids

The weight may be checked at any time during the competition with the quantity of liquids in the tanks, except after qualifying and the races when the car may be emptied of all the consumable liquids before weighing.

ART. 6 ENGINE**6.1 Engine generals**

- The make and type of the spark plugs are free.

Engine position;; The crankshaft's axis may be moved within a cylinder with R=20mm

Only sealed engines by the manufacturers are eligible for FIA WTCR Events.

The engine will have the possibility to seal the oil sump and the cylinder head cover by the Technical Delegate.

It is not allowed to put ice or any other cooling system in the intake pipes or in front of the intercooler.

6.2 Engine CoolingIntercooler

Mass production intercooler from another OEM (maximum core volume 8 litres) may be used.

Air Ducts: free between air inlet and intercooler core

The position and brackets are free without any modification of the bodywork. Air hoses and water pipes are free

Water Cooling

Radiator: mass production part free provided that the radiator is fitted in the production location without any modification to the bodywork (see exception below), brackets, water hoses and water pipes are free

Thermostat: free. The use is optional.

Electric & mechanic fans for radiator cooling: free

Air Ducts: free between air inlet and cooler core

Engine oil cooling

The type of the used oil cooler (air/oil radiators or water/oil heat exchanger) and their connections are free. No modifications to the bodywork are allowed. The parts have to be situated within the perimeter of the bodywork in safe position.

It is allowed to put tape in the grilles of the front bumper to regulate the engine cooler temperature (in car colour).

Only ambient air may be used for heat dissipation.

6.3 Lubrication

Following is allowed:

- Pressure accumulator
- Baffles and deflectors in production oil wet sump; The distance between the planes of the oil sump gasket on the engine block and on the oil sump may not be increased by more than 6mm.

If the lubrication system includes an open type sump breather, it must be equipped in such a way that the oil flows into a catch tank. (App. J, Art. 255. 5.1.14)

6.4 Engine control unit

The choice of the engine Electronic control unit (ECU), engine control software, sensors and engine loom are free.

The software and all data sets are frozen and cannot be overwritten. ECU box will be sealed by the Manufacturer and the access to modify software and parameters will be closed to prevent manipulation.

Manufacturers will deposit on request by the technical delegate free of charge for the duration of participation of their cars to the WTCR Engine Electronic Control Unit(s) (ECU) for all registered engine performance level(s) defined for BoP purposes.

The Technical Delegate may at any time oblige the competitor to use the reference unit registered with the FIA by the Manufacturer.

Any manipulation, modification or disconnection of any certified sensor is forbidden. The Competitor is responsible for the quality of the sensor signals.

The software and the map(s) for the all certified engine performance level(s) are frozen and cannot be modified

Every manufacturer has to provide software tools (free of charge and without limitations concerning the required number of copies and licenses) to allow to the Technical Delegate to monitor the engine control software. The interface cable, that is needed to access the engine control unit while it is installed in the car, has to be provided for the Technical Delegate by all participating competitors free of charge. The engine control software and the datasets have to be provided in a binary format to the Technical Delegate by the manufacturer

The software tools have a minimum functionality of:

- Upload/Download program software and data sets
- Calculate Checksum of program software and datasets after uploading them

6.5 Intake system

One (1) supplementary opening in the front bumper without protrusion above bumper's exterior surface can be made.

The maximum boost pressure will be defined during BoP test. The boost monitoring will be defined smoothing peaks and eliminating the upshifting discrepancies.

The air filter housing and the air filter element may be replaced with a catalogue part. The air feed pipes to the air filter housing and from the filter housing to the turbo are free.

It is allowed to change the impeller in case the Turbo Charger is integrated in the exhaust manifold.

The turbo charger must have the possibility to be sealed.

Antipollution air circulation may be removed and the connections may be closed.

6.6 Exhaust

The exhaust system is free downwards the turbo charger and its regulating system. It will fit FIA homologated catalytic converter(s) (FIA List no. 8), will have nominal wall thickness minimum 1.2mm and will have the exit(s) at the car's rear end below the rear bumper.

If a different turbo charger is certified an adapter between this and exhaust manifold may be used,

The sound level must not exceed 110 dB(A) at 6000 rpm, measured in conformity with the FIA noise-measuring method.

Manufacturers may apply for one option exhaust muffler system for low noise circuits.

6.7

Fly-wheel assembly

Flywheel: production part or modified respecting following conditions:

- Fly wheel can be re-manufactured solely to allow for a replacement clutch.
- Minimum weight 6kg (without fasteners)
- Machined from a single block of steel (no weight reduction bores, pockets or cut-outs)
- The starter gear must have same or bigger dimensions.

ART. 7

FUEL SYSTEM

7.1

Fuel tanks

The fuel cell(s), the filling and ventilation systems must be separated from the cockpit by a fireproof and liquid-proof protective device and must be certified.

The total volume of the fuel cell(s) is max. 100 liters.

Designs have to be approved before implementation.

External refuelling can be used (Art. 253).

For fuel tanks with filler necks FIA homologated non-return valve is mandatory (App. J. Art. 253.14.5).

In-board fuel tank filler must be protected by a fireproof and liquid-proof fire-wall.

The use of safety fuel tanks according to FIA FT3-1999, FT3.5 or FT5 (Technical List n.1) is compulsory. They may be used according to options a) and b) below:

a)

FIA Safety Fuel Cells satisfying the following conditions:

- FIA/FT3 1999, FT3.5 or FT5 homologated
- Comply with the prescriptions of App. J, Art. 253.14
- The fuel tank must be contained in a close-fitting flameproof and liquid-proof lower (external) housing that has no other mechanical function including a crushable structure on all surfaces except the one in contact with the body shell.
- The crushable structure must be a honeycomb sandwich construction based on a fire-resistant core of a minimum crushing strength of 18N/cm². The sandwich construction must include two skins of 1.5 mm thickness having a tensile strength of minimum 225N/mm² and must have minimum thickness of 10 mm.
- Located within the safety cage, forward of the centre line of the rear wheels, no more than 65cm from the vertical plane through the longitudinal axis of the car
- Fuel cell cover's lowest surface should have similar area and position in the car as the production fuel cell.
- The rest of the fuel cell including its cover has to be higher than 40mm in respect to production fuel cell's lowest surface.
- Simple tunnel (no closed opening through fuel cell) for exhaust tube is allowed.
- The level of the fuel cell lowest (external) surface including its cover has to respect the level of the production fuel cell's lowest surface.
- Floor pan cut above the original fuel cell compartment exclusive for the installation of the supplementary fuel cell volume in the cockpit is permitted. Structural panels cannot be cut or modified.
- The upper (internal) housing may be of mild steel 1.5mm minimum nominal thickness bolted or welded to the body shell or be crushable structure with similar properties as the lower housing.
- Fuel cell housing fixation to the body shell will be made using at least 6 (six) fixing points with M8 grade 8.8 bolts installed according to the FIA Drawing 253-65. fixing systems with equivalent solidity may be used if previously approved and certified. An add-on fuel cell (FT3 1999, FT3.5 or FT5) on the top of the main fuel cell and installed in a housing corresponding to this regulation may be used up to the total maximal fuel volume.

b)

It is also possible to use a catalogue rectangular shaped FIA Safety Fuel Cell coming from an FIA-approved manufacturer (FIA FT3 1999, FT3.5 or FT5)..

The Fuel Cell must be fitted as follows:

- located within the safety cage
- forward of the centre line of the rear wheels
- behind the vertical plane tangent to the most rear point of the driver's seat back
- no more than 65cm from the vertical plane through the longitudinal axis of the car
- Installed in a fabricated mild steel vane (housing) 1.5mm minimum nominal thickness bolted or welded to the body shell; or in a housing corresponding to the point a) of this article bolted to the body shell. The housing will follow the fuel tank's shape and will not have any other function.
- Cut-out of the floor pan is permitted.
- Lower surface of the tank vane at least 100mm above road (measured by ride height of 80mm).
- mild steel 1.5mm minimum nominal thickness fuel cell cover bolted or welded to the body shell (fire wall)
- An add-on fuel cell (FT3 1999, FT3.5 or FT5) on the top of the main fuel cell and installed in a housing corresponding to this regulation may be used up to the total maximal fuel volume.
- In case of bolting (fuel cell housing or cover) minimum M6 8.8 bolts spaced at max. 200mm must be used. Different designs have to be approved before implementation.

7.2	<p>Fuel circuit</p> <p><u>Fuel lines:</u> Mass Production Fuel Lines may be used outside the cockpit. The protection will correspond to Appendix J, Art. 253.3.1. Other fuel lines must correspond to the prescriptions of Article 253-3 of Appendix J. The installation is free provided that the prescriptions of Article 253-3 of Appendix J are respected.</p> <p><u>Fuel sampling connector</u> The car must be fitted inside the engine compartment with a FIA approved self-sealing connector for fuel sampling (Technical list n°5) on the fuel feed line directly before the fuel high pressure pump. The competitors will provide to the Technical Delegate on his request a connection hose to this connector.</p>
7.3	<p>Electric Fuel Pumps</p> <p>All Electric Fuel Pumps must stop when the engine stalls.</p>
ART. 8	ELECTRICAL EQUIPMENT
8.1	<p>Windscreen wiper</p> <p>Any production wiper motor system may be used with at least 1 (one) original working wiper blade to clear the screen directly in front of the driver. The windscreen washer tank may be modified (free position) or removed. Complete rear window wiper and washer system may be removed.</p>
8.2	<p>Engine Starter</p> <p>The production starter must be fitted and must be in working order at all times of the competition. The driver must be able to operate the starter when seated normally. Manufacturers may apply for alternative OEM Starter.</p>
8.3	<p>Lighting equipment</p>
8.3.1	<p>The exterior lighting equipment must at least ensure the following functions: headlights, front and rear direction indicators, stop lights, rain light (see 8.3.2) and rear tail lights and must be in working order at all times of the competition. The exterior surface and appearance of the other lights cannot be modified but the interior elements may be removed.. Exception for the fender indicators which are free.</p>
8.3.2	<p>Rain lights: Rain Light is compulsory. Following arrangement may be used:</p> <ul style="list-style-type: none"> - One FIA approved unit (Technical List n°19) located in the tail gate, boot lid or replacing the 3rd brake light placed on the car's centre line. - Production 3rd brake light in combination with the production rear fog light(s).
8.4	<p>Starter Battery</p> <p>Only 1 (one) dry starter battery is allowed. Type: certified (Li-Ion or other exotic types will not be accepted). Capacity: free Make: free as far as the certified capacity, location, protection and fixation are used. Location: In the production location, boot or in the cockpit. If in the cockpit, it must be situated behind a vertical and transversal tangent plane to the rearmost point of driver's seat or in the rear passengers' foot well. Fixation: Should the battery be moved from its production position App. J, Art.255.5.8.3 applies. Insulating cover: The terminals must be electrically protected with an insulating cover. It must be possible at all times to start the engine with the energy of the battery transported on board the vehicle.</p>
8.5	<p>Electric loom (engine, car & data logger)</p> <p>Production or racing loom.</p>
ART. 9	TRANSMISSION
9.1	<p>Transmission system</p> <p>For cars fitted with a paddle shift and/or a power-driven clutch with electronic or pneumatic control, the Technical Delegate may at any time oblige the competitor to use in competition the reference unit(s) registered with the FIA by the Manufacturer.</p>
9.2	<p>Clutch</p> <p>The clutch has to be the mass production one or certified under following conditions:</p>

- Racing Catalogue pressed-type multi-discs sinter-cerametalllic
- Minimum Discs Dia. 183mm (7¼")
- Clutch Control System hydraulic or mechanic actuated by the driver's foot
- Clutch release bearing is free (catalogue parts).

9.3 Gearbox

Mass production gearbox coming from the production model or from another car of the same group may be used. In the latter case a gear box adapter to the engine and gearbox brackets may be used.

The mass production gearbox will be certified and used under following conditions:

- Mass production ratios
- 1 (one) reverse gear, selectable at any moment by the driver while the engine is running and the car is stopped
- Every gear must be able to be engaged and in working order.
- Gear changes must be made mechanically or using Paddle Shift (after-market or catalogue part).
- Interference to Engine Control for shifting allowed (Ignition cut or power reduction)
- Each individual gear change must be separately and solely initiated and commanded by the driver.

The use of paddle shift on mass production gearbox using catalogue (after-market) parts may be certified. The gear box control unit will be sealed and may be at any time be replaced by the technical delegate with the reference part. It is not allowed to alter the certified operating data. Manufacturers will provide to the technical delegate free of charge for the duration of participation of their cars in WTCR transmission Electronic Control Unit(s) (ECU).

One racing sequential gearbox with one set of ratios may be certified under following conditions:

- A maximum of 6 (six) forward gears
- 1 (one) reverse gear, selectable at any moment by the driver while the engine is running and the car is stopped
- Every gear must be able to be engaged and in working order.
- Gear changes must be made mechanically or using Paddle Shift (catalogue part).
- Interference to Engine Control for shifting allowed (Ignition cut or power reduction)
- Each individual gear change must be separately and solely initiated and commanded by the driver.
- Any system that permits more than one gear pair to be engaged to the drive train at any time is prohibited.
- Instantaneous gearshifts are forbidden.
- Gearshifts have to be distinct sequential actions where the extraction of the current dog gear is subsequently followed by the insertion of the target dog gear.
- The dog gear is considered extracted when its position is not able to transmit any torque.

A new gearbox cooling using catalogue parts (pump, filter, cooler, lines, thermostat, etc.) may be certified. Mass Production Gearbox Cooling may be used without modification. Modified mass production gearbox cooling must be also certified.

Each car will have to keep declared transmission.

9.4 Final Drive

The final drive may be production or bespoke.

For each certified gear box one new final drive ratio or one new final drive ratio pair (for transmission using two final gear pairs for gearboxes with 2 lay shafts) in the certified housing may be certified.

Final drive cooling using catalogue parts (pump, filter, cooler, lines, thermostat, etc.) may be certified.

9.5 Limited Slip Differential

Any mass production limited slip differential may be used in mass production gearbox with production parameters but the settings cannot be modified during driving.

The mass production differential fitted in the mass production gearbox may be replaced by a catalogue mechanical limited slip differential inside the drive unit housing.

It is permitted to remove material from the inside of the production housing. It must at all times be possible to clearly recognize the housing as the certified standard housing.

Only one (1) catalogue mechanical limited slip differential may be offered for each racing sequential gearbox.

For each mechanical limited slip differentials 4 (four) pairs of pressure angles machined on one or several pressure rings pairs may be certified.

The use of metallic friction plates & disks is mandatory (no carbon friction plates / disks or CFRP plated parts allowed).

9.6 Drive shafts

For each certified gear box different drive may be certified. Principle of the joint on the wheel side must be as original. Drive shaft's length is free.

ART. 10 AXLES, SUSPENSION AND STEERING**10.1 Generals**

Wheelbase: Nominal wheelbase of the race car must not exceed the nominal wheelbase of the original car + 60 mm with the following constraints:

- The wheels can only be moved towards their end (i.e. front wheel towards the front) by 30 mm maximum.
- This measurement must be taken from a datum-point on the body shell.
- Tolerance on race car wheelbase = +/- 10 mm

Front and Rear overhangs

- Front: Defined by front bumper & Front splitter position.
- Rear: Defined by rear bumper position.
- These measurements must be taken from a datum-point on the body shell.

No modifications of the chassis for new suspension pick up points

- The position of the new pick-up points is free; max ± 20 mm adjustment in all directions
- Bolted brackets for suspension elements are free

Reinforcement bars may be fitted on the McPherson top mounting points to the body shell of the same axle, each side of the car's longitudinal centreline.

The distance between the McPherson top mounting and the anchorage point of the bar cannot be more than 150 mm (Drawing 255-4), unless the bar is a transverse strut homologated with the safety cage.

Reinforcement bars must be removable.

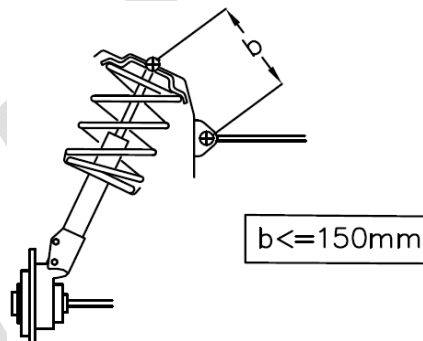

The mounting bracket may be welded or bolted to the body shell.

If bolted, a maximum of three (3) holes (maximum diameter of 10.5 mm) are authorised on each side.

The reinforcement bar must not be mounted elsewhere on the body shell or any mechanical part.

10.2 Wheel Hubs and Bearing

The wheel hubs may be re-machined using similar wheel fixation (number of fixation points, same bolt PCD and thread), to allow the use of a stronger mass production wheel bearing. Mass production wheel hubs may be used.

10.3 Bearings, Silent blocks, Rubber bearing

Production bearing on suspension arms may be replaced by uniballs or bush bearings. No rolling contact bearings accepted.

10.4 Front wishbones/upright/struts

The working principle and the number of pivot points on the wishbones/upright/struts and on the chassis/subframe have to be maintained. The parts are free.

Double-wishbone axle may be changed to triangular control arm axle.

10.5 Rear suspension

Production suspension parts may be reinforced or modified. Suspension arms may be replaced by new parts

Twist beam may be changed into double trailing arm, keeping the same external pivot points and adding two additional points on chassis.

10.6 Anti-roll bars

Anti-roll bars made from ferrous material, their bearings and their actuation are free. Adjustable lever arms (no turning blades) may be used without adjustment from the cockpit.

If the production axle is not fitting anti-roll bar, it may be added.

The anti-roll bars may be disconnected but must remain in the car.

10.7	<p>Springs</p> <p>Cylindrical, linear steel springs are free; the combination of one helper with one suspension spring is allowed.</p> <p>The spring seats are free.</p> <p>Bump stops and packers are free.</p>
10.8	<p>Minimum Ride height</p> <p>The minimum ride height has to be respected at any time during the event.</p> <p>For the checking of the minimum ride height, the pressure of the tyres must not be less than 1.5bars.</p> <p>Minimum Ride Height: 80mm.</p>
10.9	<p>Shock absorbers</p> <p>Only commercial hydraulic 2 way adjustable shock absorbers are allowed.</p> <p>Inertial shock absorbers and rolling contact bearings are forbidden.</p>
10.10	<p>Steering</p> <p>The steering lock must be dismantled and the column adjusting system must be locked with tools. Steering column brackets may be replaced. The new brackets may be connected to the chassis or to the safety cage</p> <p>A catalogue closed steering wheel can be used. The fitting of displays, switches and control lights on the steering wheel is allowed if offered by the steering wheel supplier.</p> <p>It is possible to certificate a new steering rack. All components of the new one must be of OEM mass production origin with minimal modifications for race usage and parts matching. (Origin has to be proved). Chassis firewall could be locally modified to adapt new routing for steering column. Steering column could be modified to be adapted to new steering rack spline.</p> <p>The steering wheel must be fitted with a quick release system.</p>
10.11	<p>Power steering</p> <p>For cars fitted with an automatically variable power steering the Technical Delegate may at any time oblige the competitor to use the reference unit FIA registered by the Manufacturer.</p> <p>In case of using different steering rack the correspondent assistance principle can be used with parts of OEM mass production origin.</p>
ART.11	<p>BRAKES</p>
11.1	<p>Generals</p> <p>Master cylinder(s) are free; The type and make will be certified.</p> <p>Max brake diameter 380mm (width free); certified diameter and bells</p> <p>Steel brake discs (no ceramic coating allowed)</p> <p>Max 6 pistons front calliper</p> <p>Max 2 pistons rear calliper</p> <p>The brake callipers must be made from aluminium materials with a modulus of elasticity no greater than 80Gpa.</p> <p>Simple brake effort repartition system(s) (hydraulic or/and mechanic) is (are) allowed.</p>
11.2	<p>Brake fluid tanks</p> <p>The brake and clutch fluid tanks will be fixed in the engine bay. The brake fluid hoses may pass through the cockpit.</p>
11.3	<p>Brake cooling</p> <p>Ducts may be steel or aluminium sheet, flexible hoses or be made in composite material.</p> <p>Certified apertures in the bodywork may be used to bring the cooling air to the brakes.</p> <p>The connection of the air ducts to the certified apertures in the bodywork is free.</p> <p>Two supplementary openings in the front bumper may be done with no other function:</p> <ul style="list-style-type: none"> - The connection parts to the bumper will have an internal diameter of maximum 100mm, will not protrude more than 15mm above bumper's outer surface having transition radius to the bumper shape max 10mm. - Flexible or firm air ducts with maximal inside dimensions of nominal 100mm diameter for circular versions or the corresponding inside area for non-circular versions may be used. <p><u>Brake disc cooling :</u></p> <p>Ducts must channel air towards the inner face of the brake disc and brake disc bell only and must not be bigger than the disc diameter.</p> <p><u>Brake calliper cooling :</u></p> <p>Ducts may wrap the calliper up to a maximum of 20mm around it.</p> <p>Tape on the external air inlets to regulate the brake temperature is allowed (in car colour).</p>

11.4	<p>Parking brake</p> <p>The parking brake working on the brake system (not on the transmission) is mandatory. The production parking brake may be removed or replaced by a hydraulic valve or master cylinder operated manually by the driver without any intermediate system.</p>
ART. 12	WHEELS AND TYRES
12.1	<p>Generals</p> <p>Any system allowing the car to be driven without pressure in the tyres is forbidden. Pressure and temperature sensors are forbidden.</p>
12.2	<p>Dimensions</p> <p>Wheels:</p> <ul style="list-style-type: none"> - Dimensions of the 4 wheels: identical - Rim's maximum dimensions : 10"x18" (width x diameter) - Complete wheel: Maximum width at 2bars : 280mm - The diameters at inner and outer rim edges must be identical with a tolerance of ± 2.0mm. - Wheel's minimum weight: 11kg - Wheel's material: Cast aluminium alloy - Wheel's Construction: Single unit - Metal inserts are allowed for the passage of the drive to the wheel. - Air extractors are forbidden. - Dry and wet weather tyres will have similar dimensions.
12.3	<p>Wheel visibility</p> <p>The upper part of the complete wheel (flange + rim + tire) in straight ahead position and above the wheel's centre must be vertically covered by the bodywork.</p>
12.4	<p>Wheel attachment</p> <p>Wheel fixations by bolts may be changed to studs fixations respectively knurled-head screws and nuts, provided that the number of fixation points, as mentioned above, remains unchanged.</p> <p>Certified wheel spacers are allowed.</p>
12.5	<p>Pressure control valves</p> <p>Pressure control valves on the wheels are forbidden.</p>
ART. 13	COCKPIT
13.1	<p>Equipment permitted in the cockpit</p> <p>The only components which can be added in the cockpit are:</p> <ul style="list-style-type: none"> - Safety equipment and structures - Seat, instruments and any other controls necessary for driving including the brake balance adjuster - Electronic and electrical equipment; it is permitted to channel air towards the electronic equipment on condition that the ventilation devices comply with the present regulations. - team communication radio - Driver cooling and ventilation equipment - Ballast - Braking and clutch system hydraulic lines with properly secured connectors - Pneumatic jacks and their pipes - Battery - Fuel, hydraulic lines with properly secured connectors (App. J. Art. 253.3.2) <p>None of the above items may hinder cockpit exit or the driver's visibility.</p> <p>The above components must be covered where necessary by a rigid protective material to minimise injury, and their mountings must be able to withstand 25g deceleration.</p>
13.2	<p>Cockpit exit time</p> <p>The driver, seated in his normal driving position, must be able to get out from the cockpit in 7 seconds through the driver's door and in 9 seconds through the passenger's door.</p> <p>For the purposes of these tests, the driver must be wearing all normal driving equipment, the seat belts must be fastened, the steering wheel must be in place, and the doors must be closed.</p>

13.3	<p>Test for helmet removal</p> <p>With the driver seated in his normal driving position in the car with which he is entered, wearing a frontal head restraint system according to FIA Standard 8858-2010 (FIA List No. 29) appropriate to his size and with the seat harness tightened, it must be possible, that the helmet which the driver will wear in the race can be gently removed from his head without bending his neck or spinal column.</p>
ART. 14	SAFETY EQUIPMENT
14.1	<p>Fire extinguishers</p> <p>All cars must be equipped with an extinguishing system homologated by the FIA in accordance with Article 253.7.2. (FIA Technical List 16). (Certification)</p>
14.2	<p>Safety belts</p> <p>The safety belts must comply with FIA Standards N°8853/98. (FIA Technical List 24) and have to use the certified fixing points.</p>
14.3	<p>Rear view mirrors</p> <p>The car must be fitted with 2 (two) production external rear view mirrors.</p>
14.4	<p>Driver Seat</p> <p>The driver's seat must be FIA homologated and not modified:</p> <ul style="list-style-type: none"> - FIA Standard 8855-1999 (FIA Technical List 12) using exclusively WSC certificated seat brackets. (Certification) - Several homologated seats of the certified seat model may be used with certificated seat brackets (Certification) - FIA Standard 8862-2009 (FIA Technical List 40) <p>Maximum total thickness of cushions used between the driver and the homologated seat is 50mm.</p> <p>If the original seat attachments points on the body shell are changed, the new attachments points for seat or seat supports must comply with the provisions of App. J, Art. 253.16.</p> <p>The seat must be mounted by means of at least four (4) M8 bolts of at least 10.9 quality.</p> <p>Seat position</p> <ul style="list-style-type: none"> - Transversally: Seat centreline must not be less than 270mm from the car's centreline. - Longitudinally limit: No part of the seat may be situated beyond the vertical and transverse plane defined by the front edge of the original back seat. The most rear seat position will be documented in the Technical Form related to the chassis.
14.5	<p>General Circuit Breaker</p> <p>The driver, when seated normally at the steering wheel with the safety belts fastened, must be able to cut off all the electrical circuits and switch off the engine by means of a spark-proof breaker switch.</p> <p>The switch must be positioned on the dashboard or in any other place easily accessible and must be able to be handled from inside the car by the driver seated and secured by his safety belts</p> <ul style="list-style-type: none"> - An exterior General Circuit Breaker must be installed in compliance with Article 253.13 of the Appendix J Recommended location: at the lower part of the driver's side windscreen pillar.
14.6	<p>Window Net</p> <p>A protective net is compulsory.</p> <p>It must meet the following specifications:</p> <ul style="list-style-type: none"> - the net must be made up of woven strips at least 19mm (3/4") wide; - the meshes must be a minimum of 25 x 25mm and a maximum of 60 x 60mm. The woven strips must be non-flammable and sewn together at each point of crossing. The net must not be of a temporary nature. - viewed from the side, it must reach from the centre of the steering wheel to the B-pillar. <p>Fixation:</p> <p>The net must be attached either to the safety cage or to the chassis, above the driver's window, by means of a rapid release system that will function even if the car turns over.</p> <p>The net must open from the top downwards when car is on wheels.</p> <p>The use of "Velcro" lock is not permitted.</p> <p>It must be possible to detach the net with one hand. To this end, the handle or lever must have coloured markings ("dayglo" orange).</p> <p>A push-button release system is authorised provided that it respects the prescriptions of this article.</p> <p>The push-buttons must be visible from the outside, be of a contrasting colour and be marked "press".</p>
14.7	<p>Towing devices</p> <p>All cars will be equipped with certified rear and front towing devices. It will be clearly visible and coloured in yellow, red or orange.</p> <p>The towing devices must be within the perimeter of the bodywork as viewed from above.</p> <p>It must allow the passage of a cylinder with a diameter of 60mm.</p>

	<p>It must allow moving the car with blocked wheels using the cars braking system on a dry surface (concrete or asphalt) by applying traction on a plane parallel to the ground, with an angle of $\pm 15^\circ$ to the longitudinal centreline of the car. The car must be fitted with the control dry weather tyres. Flexible towing devices must be always in good condition without abrasions or kinks.</p>
14.8	<p>Fuel system</p> <p>Fuel lines : Flexibles lines inside the cockpit must be of aviation quality (App. J, Art. 253.3.2). The installation is free provided that the prescriptions of App. J, Art. 253.3 are respected.</p>
14.9	<p>Hydraulic pressure lines</p> <p>App. J, Art. 253.3.2 applies.</p>
14.10	<p>Side Protection Panel</p> <p>A side protection panel, made of composite material, fixed to the body shell or the safety cage may be optionally used.</p>
ART. 15	<p>SAFETY STRUCTURES</p>
	<p>Safety cage</p> <p>The safety cage must be homologated or certified by an ASN (App. J, Art. 253.8.1.b), or homologated by the FIA (App. J, Art. 253.8.1.c). Article 253.8.4 of the Appendix J applies.</p>
ART. 16	<p>FUEL</p>
16.1	<p>Fuel specification</p> <p>The fuel complies with FIA App. J, Art. 252.9 however not exceeding guaranteed Super Plus Quality 98 RON and 88 MON with maximum 5% ethanol content (EN228). The fuel must comply with the official samples at any time of the competition. Additives of any kind are forbidden. The fuel temperature may not be more than 20°C lower than the ambient temperature.</p>
16.2	<p>Air</p> <p>Only air may be mixed with the fuel as an oxidant.</p>
ART. 17	<p>FINAL TEXT</p> <p>The binding text of these regulations is the English version.</p>