



FEDERATION INTERNATIONALE DE L'AUTOMOBILE

Homologation N°

SH.022.17-T-6

Date

16.11.2017

FICHE DE PRESENTATION DES HARNAIS DE SECURITE (NORME FIA 8853-2016)
PRESENTATION FORM FOR SAFETY HARNESSSES (FIA STANDARD 8853-2016)

1. GENERALITES / GENERAL

101. CONSTRUCTEUR / MANUFACTURER

SCHROTH SAFETY PRODUCTS GMBH

- a) Adresse
Address IM OHL 14, 59757 ARNSBERG / GERMANY
- b) Téléphone
Phone +49 2932 9742 0
- c) E-mail
E-mail GERMANY@EU.SCHROTH.COM

102. PHOTO DU HARNAIS COMPLET / PICTURE OF THE COMPLETE HARNESS



103. MODELE DU HARNAIS / HARNESS MODEL

- a) Modèle
Model **ENDURO 3X2**
- (6-POINT HARNESS BELT WITH 3" SHOULDER BELTS AND WITH 2" PELVIC STRAPS)**

Marque
Make

SCHROTH SAFETY PRODUCTS
GMBH

Modèle
Model

ENDURO 3X2
(6-POINT HARNESS BELT WITH 3"
SHOULDER BELTS AND WITH 2"
PELVIC STRAPS)

SH.022.17-T-6

2. DETAILS DU HARNAIS / DETAILS OF HARNESS

201. SANGLES / STRAPS

	Matériau Material	Largeur Width (mm)	Position Position
			shoulder straps
201.01 GU 19.10.x (x=colour key)	polyester	3"	
201.02 GU 10.7.x (x=colour key)	polyester	1"	crotch strap loops
201.03 GU 15.7.x (x=colour key)	polyester	2"	pelvic straps
201.04 GU 11.6.x (x=colour key)	polyester	2"	crotch straps
201.05			
201.06			

202. VUES DES PIÈCES DE FIXATION/ ATTACHMENTS VIEWS

A1-1) Position / Position : **right shoulder strap**

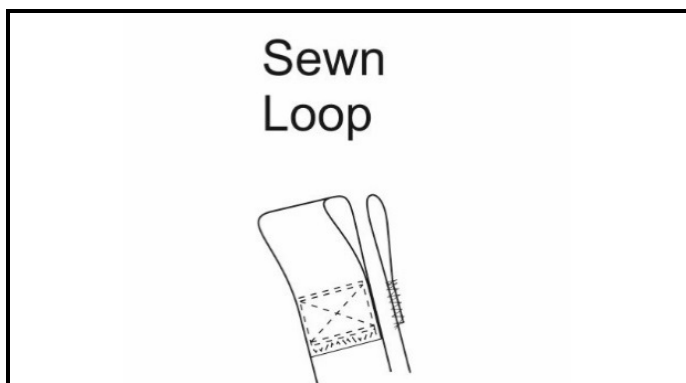

A1-2) Position / Position : **left shoulder strap**

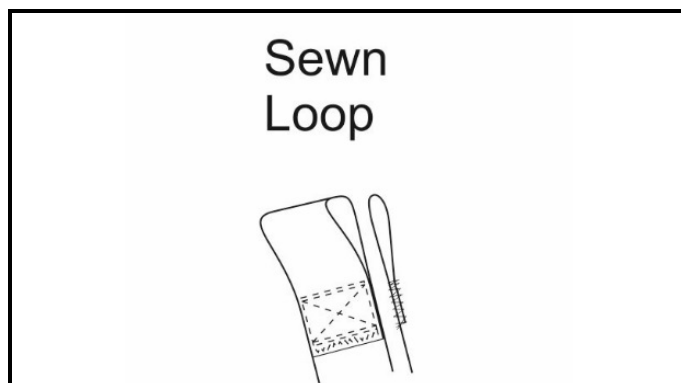

Marque **SCHROTH SAFETY PRODUCTS**
 Make **GMBH**

Modèle
 Model

ENDURO 3X2
(6-POINT HARNESS BELT WITH 3"
SHOULDER BELTS AND WITH 2"
PELVIC STRAPS)

SH.022.17-T-6

A1-3) Position / Position : **right pelvic strap**

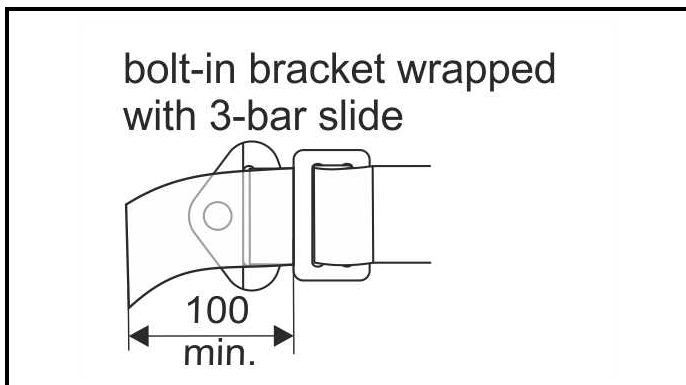

A1-4) Position / Position : **left pelvic strap**

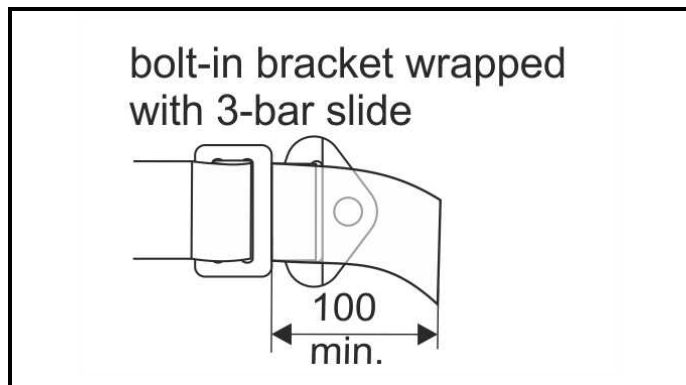

A1-5) Position / Position : **right crotch strap**

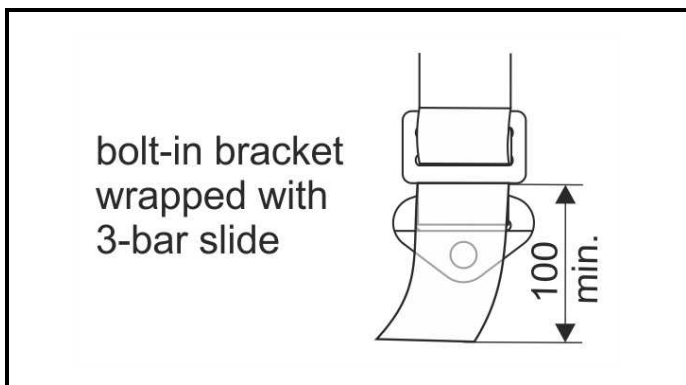

A1-6) Position / Position : **left crotch strap**

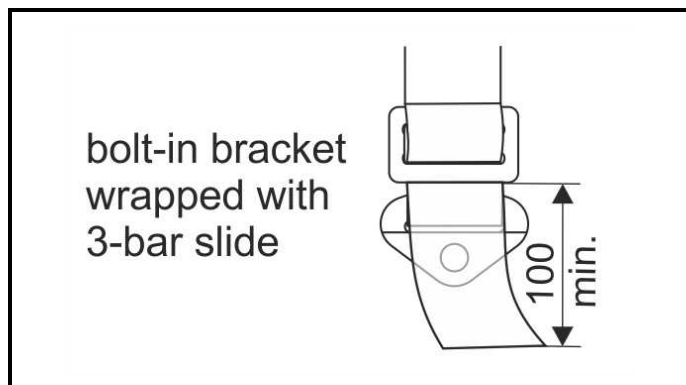

203. VUES DES DISPOSITIFS DE REGLAGE/ ADJUSTING DEVICES VIEWS

A2-1) Position / Position : **3" right and left shoulder (optional release strap)**

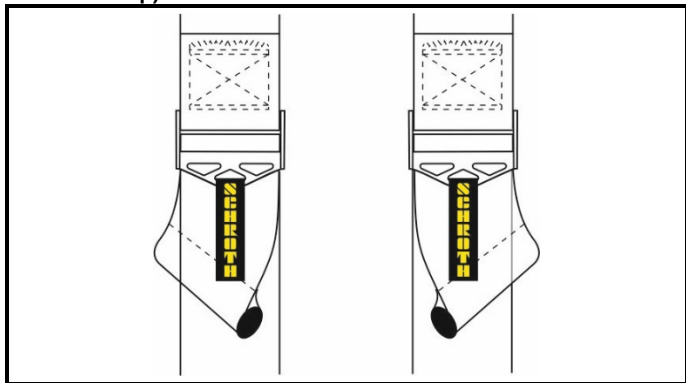

A2-2) Position / Position : **2" right and left crotch strap (optional release strap)**

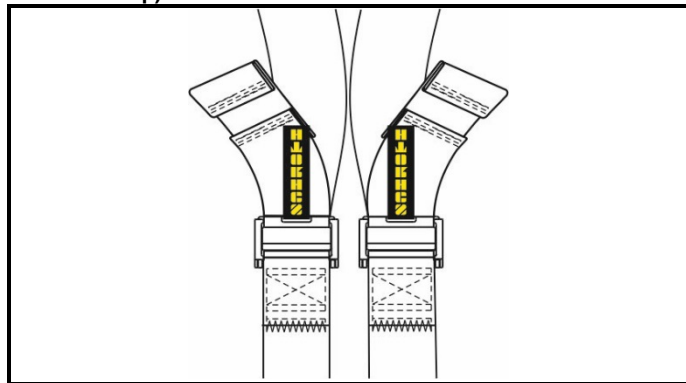

A2-3) Position / Position : **2" right pelvic adjuster latch (opt. release strap) pull-down configuration**

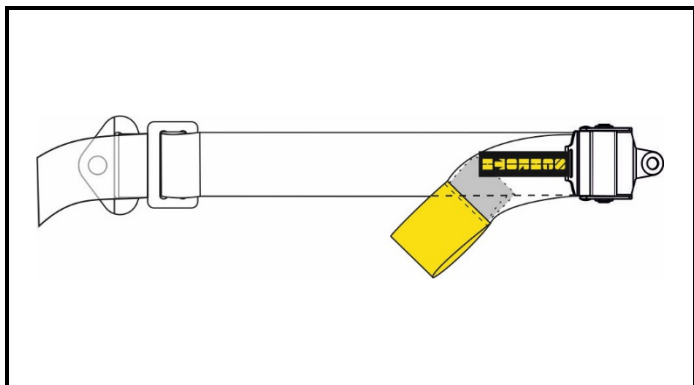

A2-4) Position / Position : **2" left adjuster latch (opt. release strap) pull-down configuration**

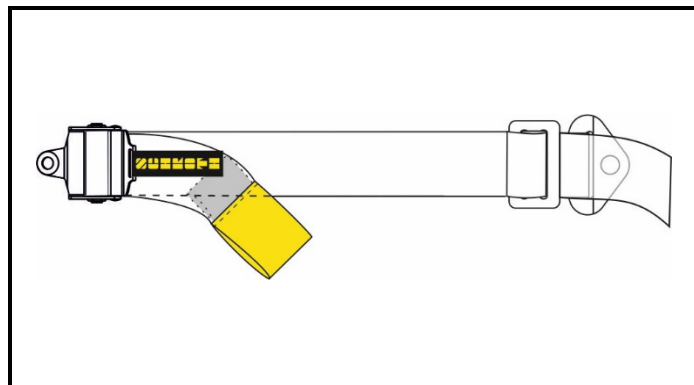

Marque
Make **SCHROTH SAFETY PRODUCTS
GMBH**

Modèle
Model

ENDURO 3X2
(6-POINT HARNESS BELT WITH 3"
SHOULDER BELTS AND WITH 2"
PELVIC STRAPS)

SH.022.17-T-6

204. BOUCLE / BUCKLE

204.1 Boucle à libération complète / Full release buckle Material

Oui / Yes



Non / No



A3-1) Vue de la boucle / Buckle view

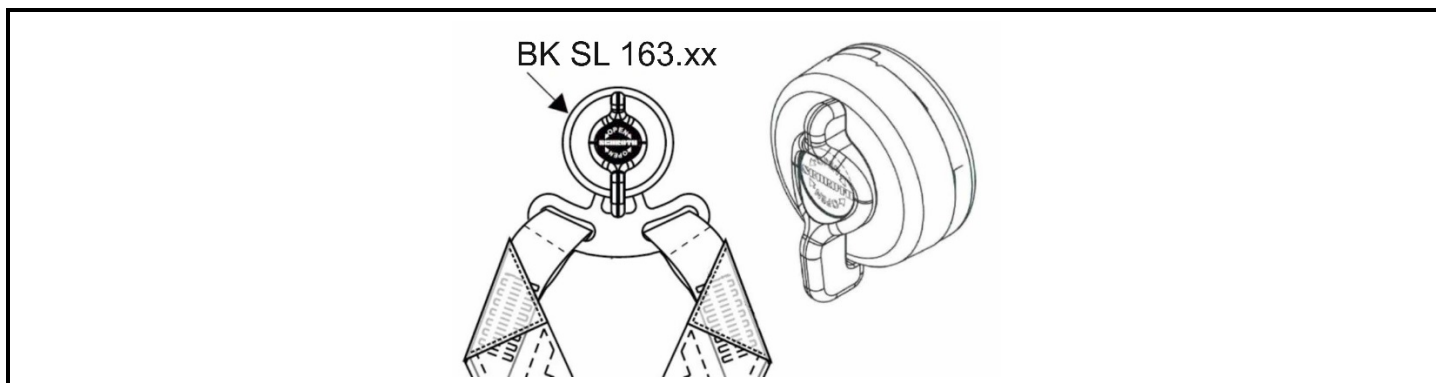

3. ETIQUETTES D'HOMOLOGATION ET DE IDENTIFICATION / HOMOLOGATION AND IDENTIFICATION LABELS

301. ETIQUETTES / LABELS

a) Dimensions [mm]
Dimensions [mm]

Etiquette d'homologation
Homologation label

height 44 x width 84 (+stitching areas)

Etiquette d'identification
Identification label

height 40 (+ stitching areas) x width 44

B1-1) Etiquette d'homologation et autocollant FIA cousus sur le harnais
Homologation label and FIA sticker stitched on the harness

In compliance with: FIA Standard 8853-2016	
Manufacturer Name:	SCHROTH Safety Products GmbH Im Ohl 14 • 59757 Arnsberg • Germany
Serial N°:	BARCODE: EAN Code 39 DHyyzzzzz
Homologation N°: SH.022.17-T-6	
Not valid after : 20JJ	

B1-2) Etiquette d'homologation cousus sur le harnais
Homologation label stitched on the harness

In compliance with: FIA Standard 8853-2016	
SCHROTH	
Homologation N°: SH.022.17-T-6	
Not valid after : 20JJ	

B1-3) Marquages pour boucle a libération complète
Full release buckle marking

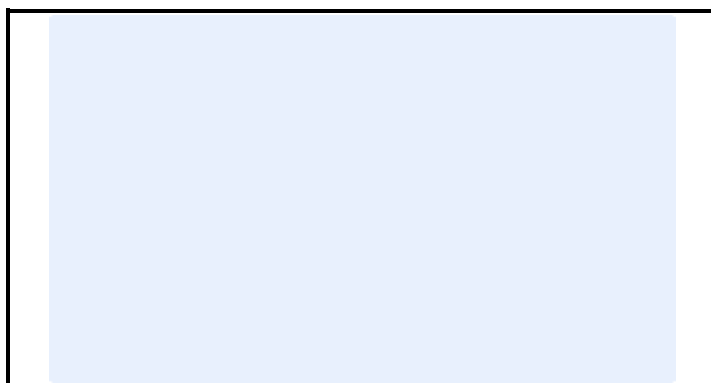

Marque **SCHROTH SAFETY PRODUCTS**
 Make **GMBH**

Modèle **ENDURO 3X2**
 Model **(6-POINT HARNESS BELT WITH 3" SHOULDER BELTS AND WITH 2" PELVIC STRAPS)**





SH.022.17-T-6

INFORMATIONS COMPLEMENTAIRES / COMPLEMENTARY INFORMATION





OPTIONAL PULL-TAB ON ADJUSTERS (with velcro)







ALTERNATIVE ATTACHMENT - CROTCH STRAP

BK B 15 wrapped w. 3-bar slide 	BK B 18.xx.yy sewn 	B 154 sewn 	B 24.xx.yy sewn 	B 24.xx.yy wrapped with 2-bar slide 
---	--	--	---	---

ALTERNATIVE ATTACHMENT - PELVIC STRAP

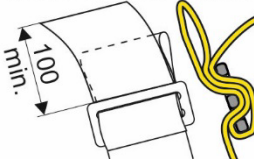
B 24.xx.yy sewn 	B 154 sewn 	B 23 A sewn 	B 43 A sewn 	BK B 15 wrapped w. 3-bar slide 
---	--	---	---	---

ALTERNATIVE ATTACHMENT - SHOULDER STRAP

Wrap Around with 3-bar slide 	BK B 15 sewn 	BK B 15 wrapped w. 3-bar slide 	B 24.xx.yy sewn 	B 24.xx.yy wrapped w. 3-bar slide 
--	--	---	---	--

Marque
Make SCHROTH SAFETY PRODUCTS
GMBH

Modèle
Model

ENDURO 3X2
(6-POINT HARNESS BELT WITH 3"
SHOULDER BELTS AND WITH 2"
PELVIC STRAPS)

SH.022.17-T-6

ALTERNATIVE CROTCH STRAP WITHOUT ADJUSTER

