



FEDERATION INTERNATIONALE DE L'AUTOMOBILE

Homologation N°

SH.021.17-T-6

Date

12.10.2017

FICHE DE PRESENTATION DES HARNAIS DE SECURITE (NORME FIA 8853-2016)
PRESENTATION FORM FOR SAFETY HARNESSSES (FIA STANDARD 8853-2016)

1. GENERALITES / GENERAL

101. CONSTRUCTEUR / MANUFACTURER

SCHROTH SAFETY PRODUCTS GMBH

- a) Adresse
Address **IM OHL 14, 59757 ARNSBERG / GERMANY**
- b) Téléphone
Phone **+49 2932 9742 0**
- c) E-mail
E-mail **GERMANY@EU.SCHROTH.COM**

102. PHOTO DU HARNAIS COMPLET / PICTURE OF THE COMPLETE HARNESS



103. MODELE DU HARNAIS / HARNESS MODEL

- a) Modèle
Model **PROFI 2X2 - GEN II**
- (6-POINT HARNESS BELT WITH 2" SHOULDER BELTS FOR FHR USE ONLY AND WITH 2" PELVIC STRAPS)**

Marque
Make

SCHROTH SAFETY PRODUCTS
GMBH

Modèle
Model

PROFI 2X2 - GEN II
(6-POINT HARNESS BELT WITH 2"
SHOULDER BELTS FOR FHR USE
ONLY AND WITH 2" PELVIC STRAPS)

SH.021.17-T-6

2. DETAILS DU HARNAIS / DETAILS OF HARNESS

201. SANGLES / STRAPS

	Matériau Material	Largeur Width (mm)	Position Position
201.01 GU 11.6.x (x=colour key)	polyester	2"	shoulder straps pelvic straps crotch straps
201.02 GU 10.7.x (x=colour key)	polyester	1"	crotch strap loops
201.03			
201.04			
201.05			
201.06			

202. VUES DES PIÈCES DE FIXATION/ ATTACHMENTS VIEWS

A1-1) Position / Position : right shoulder strap

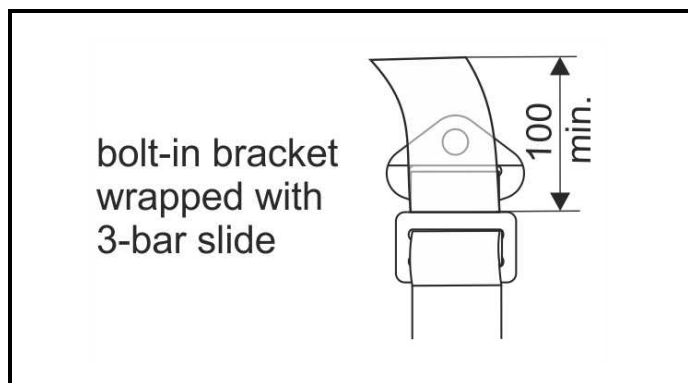

A1-2) Position / Position : left shoulder strap

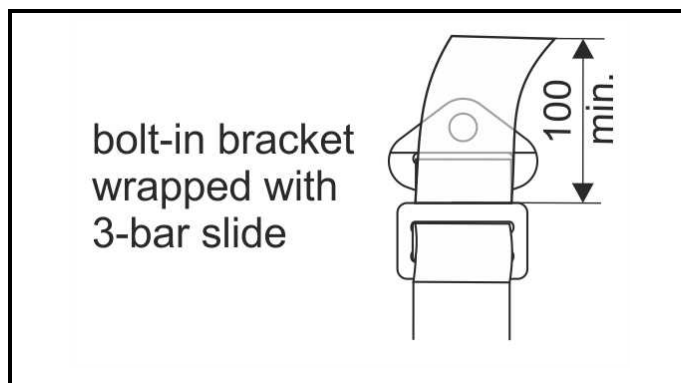

Marque **SCHROTH SAFETY PRODUCTS**
 Make **GMBH**

Modèle
 Model

PROFI 2X2 - GEN II
(6-POINT HARNESS BELT WITH 2" SHOULDER BELTS FOR FHR USE ONLY AND WITH 2" PELVIC STRAPS)

SH.021.17-T-6

A1-3) Position / Position : **right pelvic strap**

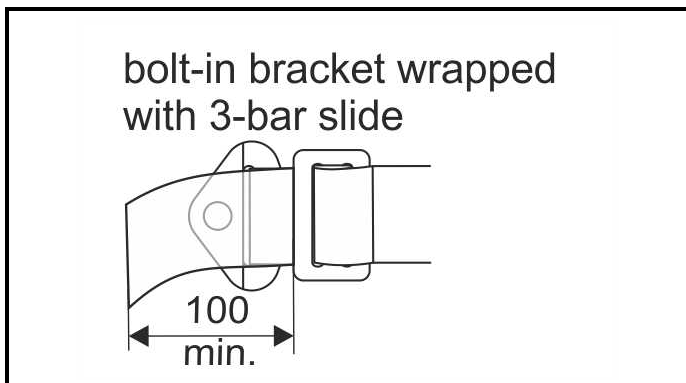

A1-4) Position / Position : **left pelvic strap**

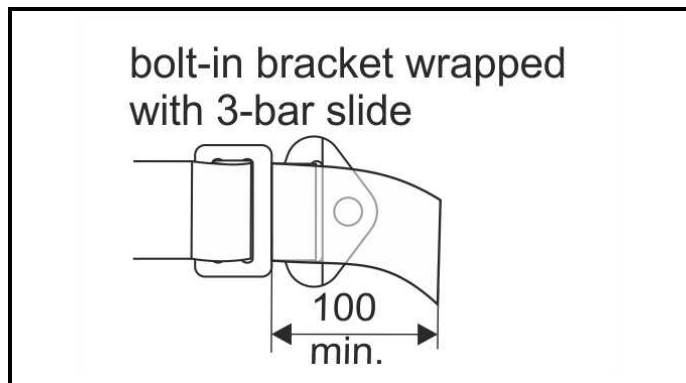

A1-5) Position / Position : **right crotch strap**

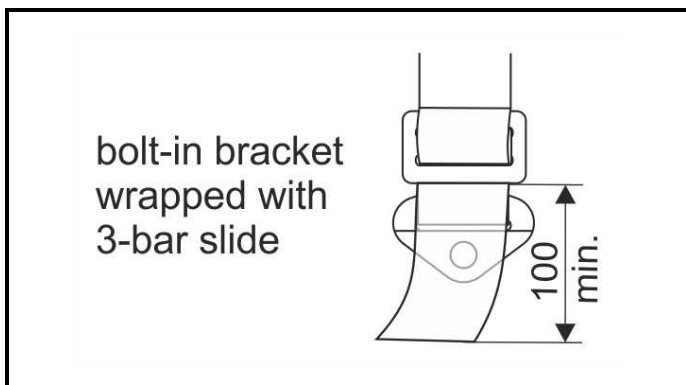

A1-6) Position / Position : **left crotch strap**

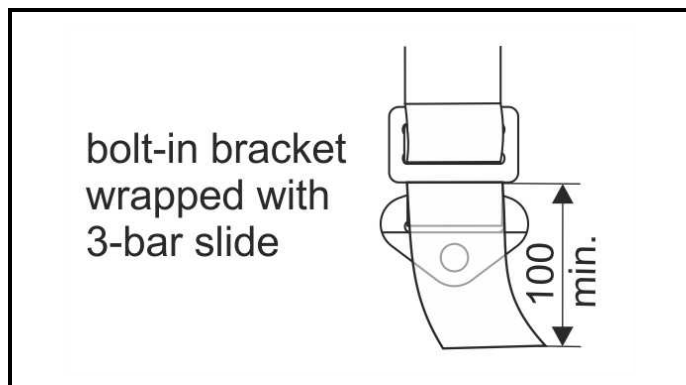

203. VUES DES DISPOSITIFS DE REGLAGE/ ADJUSTING DEVICES VIEWS

A2-1) Position / Position : **2" right and left shoulder strap (optional release strap)**

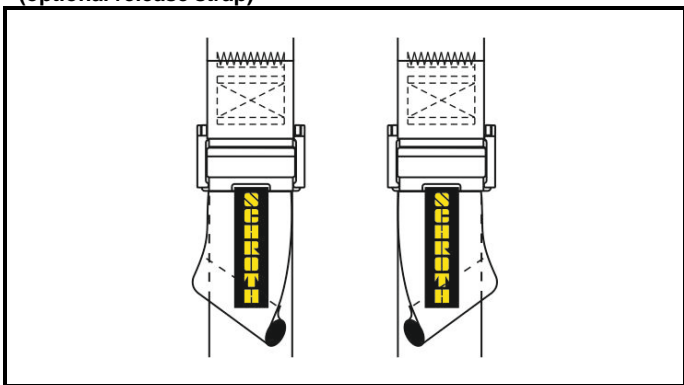

A2-2) Position / Position :

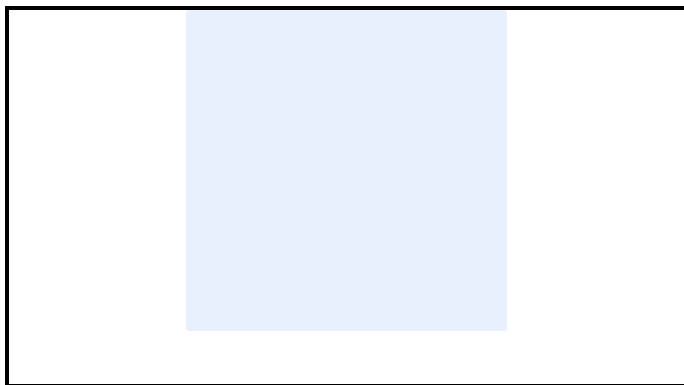

A2-3) Position / Position : **2" right pelvic adjuster (opt. release strap) pull-down configuration**

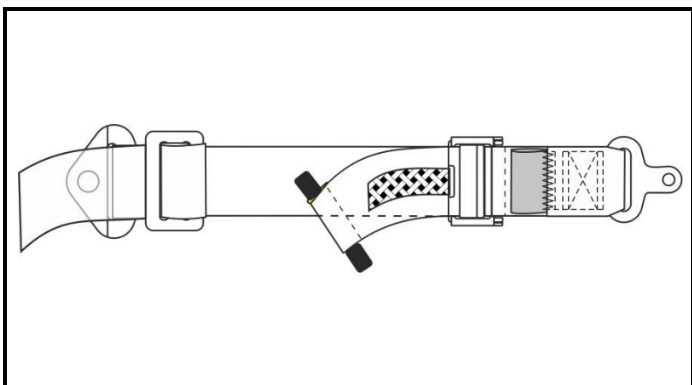

A2-4) Position / Position : **2" left adjuster (opt. release strap) pull-down configuration**

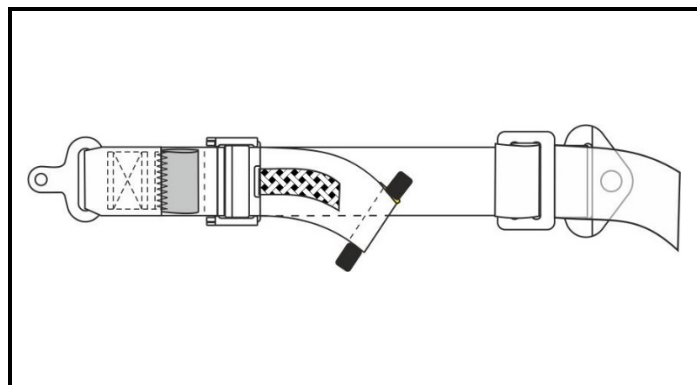

Marque
Make **SCHROTH SAFETY PRODUCTS
GMBH**

Modèle
Model

PROFI 2X2 - GEN II
(6-POINT HARNESS BELT WITH 2"
SHOULDER BELTS FOR FHR USE
ONLY AND WITH 2" PELVIC STRAPS)

SH.021.17-T-6

204. BOUCLE / BUCKLE

204.1 Boucle à libération complète / Full release buckle Material

Oui / Yes



Non / No



A3-1) Vue de la boucle / Buckle view

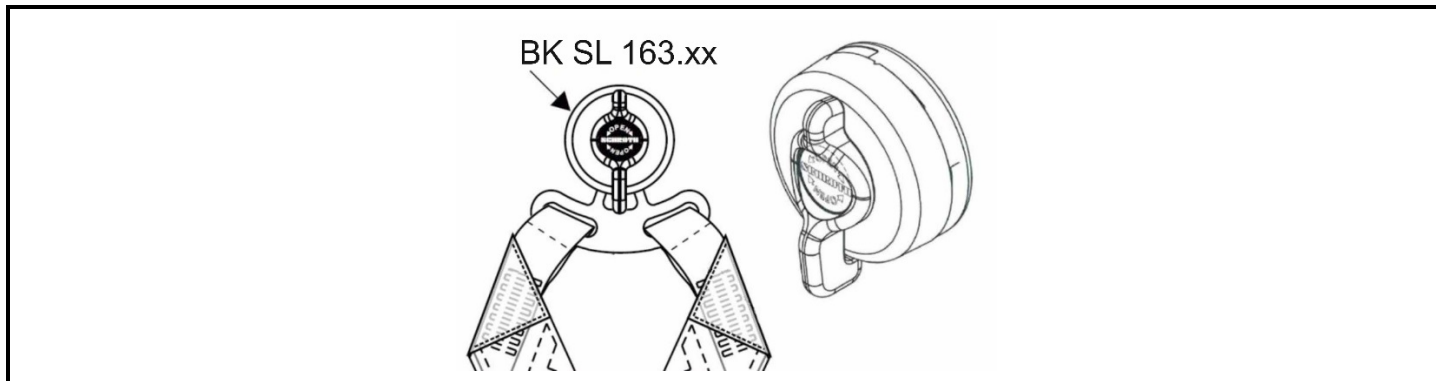

3. ETIQUETTES D'HOMOLOGATION ET DE IDENTIFICATION / HOMOLOGATION AND IDENTIFICATION LABELS

301. ETIQUETTES / LABELS

a) Dimensions [mm]
Dimensions [mm]

Etiquette d'homologation
Homologation label

height 44 x width 84 (+stitching areas)

Etiquette d'identification
Identification label

height 40 (+ stitching areas) x width 44

B1-1) Etiquette d'homologation et autocollant FIA cousus sur le harnais
Homologation label and FIA sticker stitched on the harness

In compliance with: FIA Standard 8853-2016	
Manufacturer Name:	SCHROTH Safety Products GmbH Im Ohl 14 • 59757 Arnsberg • Germany
Serial N°:	BARCODE: EAN Code 39 D1yyzzzzz For FHR use only
Homologation N°: SH.021.17-T-6	
Not valid after : 20JJ	

B1-2) Etiquette d'homologation cousus sur le harnais
Homologation label stitched on the harness

In compliance with: FIA Standard 8853-2016	In compliance with: FIA Standard 8853-2016
SCHROTH	SCHROTH
Homologation N°: SH.021.17-T-6	Homologation N°: SH.021.17-T-6
For FHR use only Not valid after : 20JJ	Not valid after : 20JJ
For right shoulder straps	For pelvic and crotch straps

B1-3) Marquages pour boucle a libération complète
Full release buckle marking

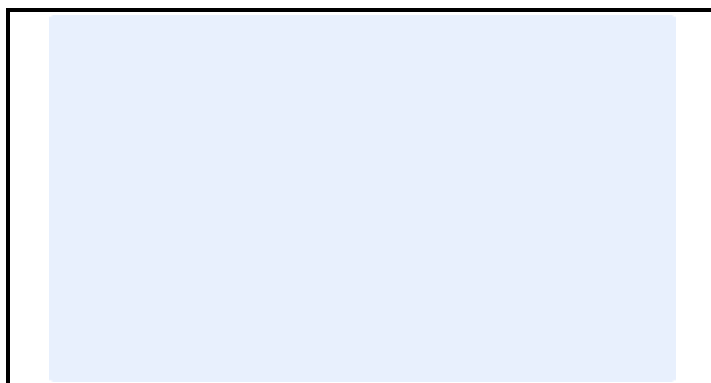

Marque
Make

SCHROTH SAFETY PRODUCTS
GMBH

Modèle
Model

PROFI 2X2 - GEN II
(6-POINT HARNESS BELT WITH 2"
SHOULDER BELTS FOR FHR USE
ONLY AND WITH 2" PELVIC STRAPS)

SH.021.17-T-6

INFORMATIONS COMPLEMENTAIRES / COMPLEMENTARY INFORMATION

OPTIONAL PULL-TAB ON ADJUSTERS (with velcro)

