

Sabelt[®]

zero[®]
360

FITTING INSTRUCTIONS

All Zero 360 FIA Systems

PLEASE READ CAREFULLY BEFORE ATTEMPTING TO INSTALL YOUR SYSTEM

Thank you for purchasing a FIA approved Zero 360 Sabelt fire system. It is important that you read these instructions carefully before attempting to install your extinguisher system.

The system should in no way be modified or tampered with as by doing so you could seriously affect its performance. If you need to replace parts, only genuine Sabelt components should be used.

Sabelt S.p.A. endeavours to provide the most accurate and up to date information for its products and reserves the right to amend specifications without notice.
E & OE.

Should you experience any difficulties installing your system, please do not hesitate to contact Sabelt at:



Sabelt S.p.A.

Via Guido Rossa, 10
Moncalieri (TO) ITALY

Tel: +39 (0) 11 6477899 Fax: +39 (0) 11 6477999

Website: www.sabelt.com

Email: info@sabelt.com

IMPORTANT NOTE

The purpose of any vehicle fire protection system is to provide a time envelope in which to control the fire in order to accomplish evacuation of the occupants. Ideally the fire will be totally extinguished, but this cannot be guaranteed. Holding back the intensity of an engine, or a cockpit fire, to enable the occupants to evacuate, or allow outside assistance to be given, is the main purpose.

CONTENTS

Page No.

3/4	Systems covered by these instructions
4	Fitting Instructions – Zero 360 Systems
5	Mechanical Systems
5	Electrical Systems
7	Wiring Diagram
9	Nozzles & Locations
10	Tubing & Connection
11	Remote Charge Systems – Checking that system has been activated
12	Kit Contents
13	Technical Specification
14	Maintenance
15	Annex – Systems Schematic Diagrams

Systems Covered in these Instructions

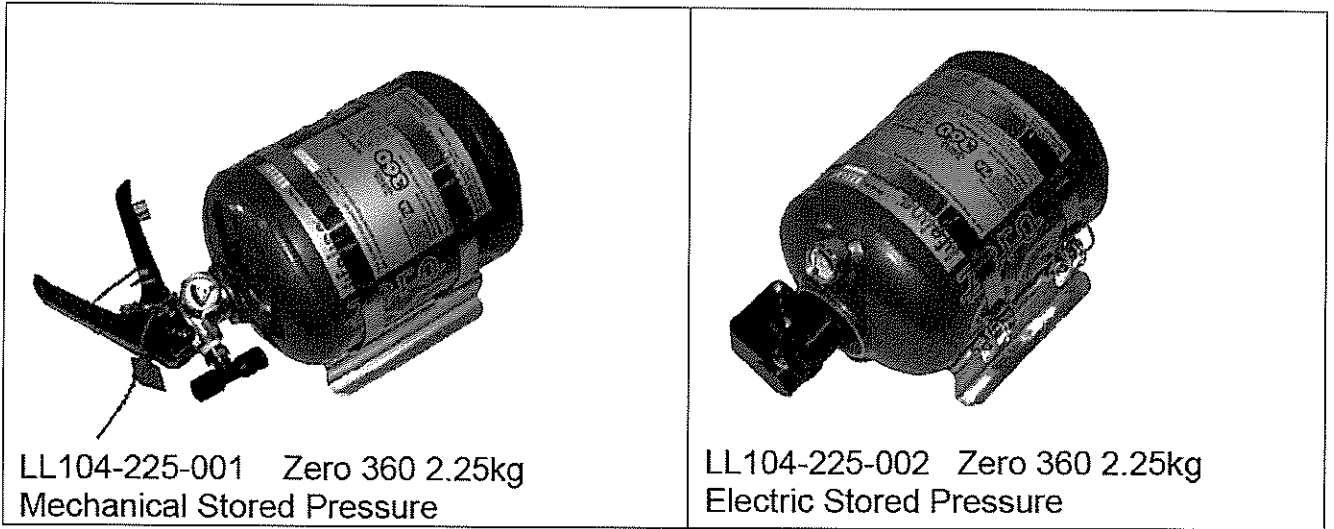

FITTING INSTRUCTIONS - ZERO 360 Systems

Unpack the kit carefully and check that all components are complete and undamaged. Lay out the components so that each may be identified.

See page XX for kit component listings.

Remove the extinguisher from its mounting brackets by undoing the over-centre clips. Decide upon the best position for the extinguisher to be mounted bearing in mind that the extinguisher label showing its contents, etc should be clearly visible.

Securely mount the brackets for the extinguisher and remote charge unit and replace the system. Brackets should be bolted to the vehicle. The extinguisher cylinder should be mounted within the safety structure and in a transverse orientation.

Extinguisher systems should always be located away from sources of high temperature i.e. exhausts.

Mechanical Systems

Mechanical systems are operated using pull cables. Each system is supplied with two cables, one being 6ft in length, and a 12ft length cable. Decide upon the best position for the pull cables to be mounted, bearing in mind that the cable mounted in the cockpit should be accessible to the driver and/or co-driver when seated in the normal driving position and wearing fully fastened seat belts. The external pull cable is normally mounted on the front scuttle of a saloon car (below windscreen) adjacent to the circuit breaker, or by the roll hoop on a single seat car or open top vehicle. When installing the pull cable on a saloon car ensure that you leave sufficient clearance for the bonnet to fully open.

The pull cables should be routed so that there are no sharp bends or S shapes in the cable thus ensuring easy operation of the cables. The end of each cable should be passed through the levers of the extinguisher head and secured using the cable clamps attached to the end of the cables. It is advisable to leave a small amount of slack in the cable to prevent accidental firing of the extinguisher.

It is recommended that the cables are periodically lubricated to prevent seizure and checked for smooth operation. Please remember to disconnect cables at the discharge head when carrying out these maintenance operations and to reconnect afterwards.

Mechanical Discharge Head Detail

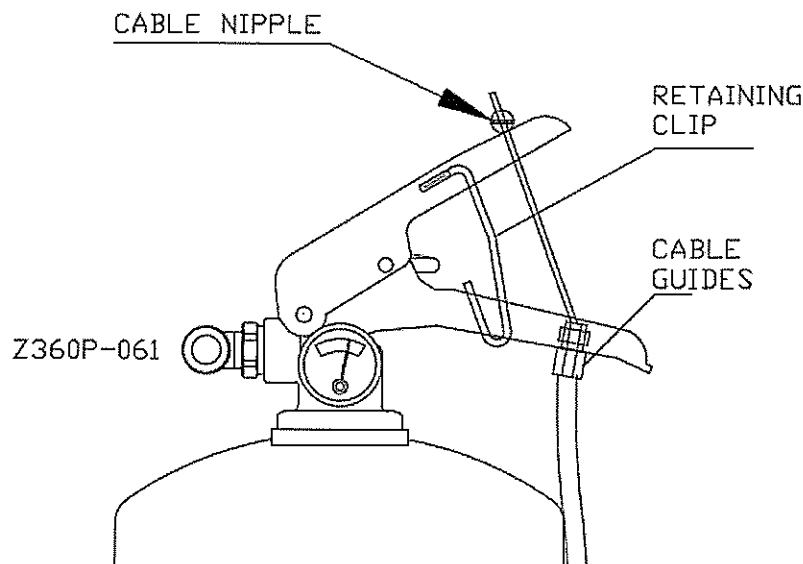

Electrical Systems

Mount the power pack so that it is clearly visible. Mount the switches to the vehicle. The cockpit switch should then be mounted so that it is within easy reach of the driver and/or co-driver when sitting in the normal position and wearing fully fastened seat belts. Where supplied the external waterproof switch is normally mounted on the front scuttle of a saloon car (below windscreen) adjacent to the circuit breaker, or by the roll hoop on a single seater or open top vehicle. The large 'E' decal must be clearly displayed next to the external switch.

Wiring of System

See wiring diagram on page XX.

All Sabelt Zero 360 electrical extinguisher kits have a separate power pack unit to provide the current needed to operate the system. The power pack should be wired independently from the vehicle's electrics as failure to do this may result in the actuation of the system due to electrical interference from the vehicle's power source. Please ensure that all wiring connections are insulated. Heat shrink sleeving is recommended.

Once the system has been wired in accordance with the wiring diagram shown on page XX, a test check should be carried out to ensure that the system will fire properly. Before you start the check procedure, ensure that the bottle and the power pack are connected.

On top of the power pack is a 3-position switch. This provides checking facilities for the battery and wiring. If the switch is pulled against its spring towards the amber LED, the LED will light if there is sufficient current in the battery. IF THE AMBER LED DOES NOT LIGHT, OR IMMEDIATELY GOES OUT, THE BATTERY SHOULD BE REPLACED. THE BATTERY SHOULD BE OF THE MAGANESE/ALKALINE LONG LIFE TYPE ONLY, TYPE PP3. Sabelt recommends that the battery be replaced regularly.

With the switch in the centre ('system isolated') position, and the centre position only, the wiring of the circuit can be checked. With the extinguisher connected, press each of the firing buttons in turn and the green LED should light. If it does not there is a break in the circuit. If the green LED lights before the switch is pressed, there is a short in the circuit and the system is permanently 'live'. If this occurs DO NOT PUT THE SWITCH INTO THE 'SYSTEM ARMED' POSITION, OR YOU WILL DISCHARGE THE SYSTEM.

If for any reason the green LED does not illuminate when the system is tested, check the wiring against the wiring diagram shown on page 7/8. If the problem persists, consult Sabelt or an agent. To arm the system place the switch in to the 'SYSTEM ARMED' position. The red LED will illuminate to indicate the system is armed.

To prolong battery life and prevent accidental activation, it is recommended that the power pack switch be in the 'SYSTEM ISOLATED' position and the plug disconnected when the vehicle is not being used.

Power Pack

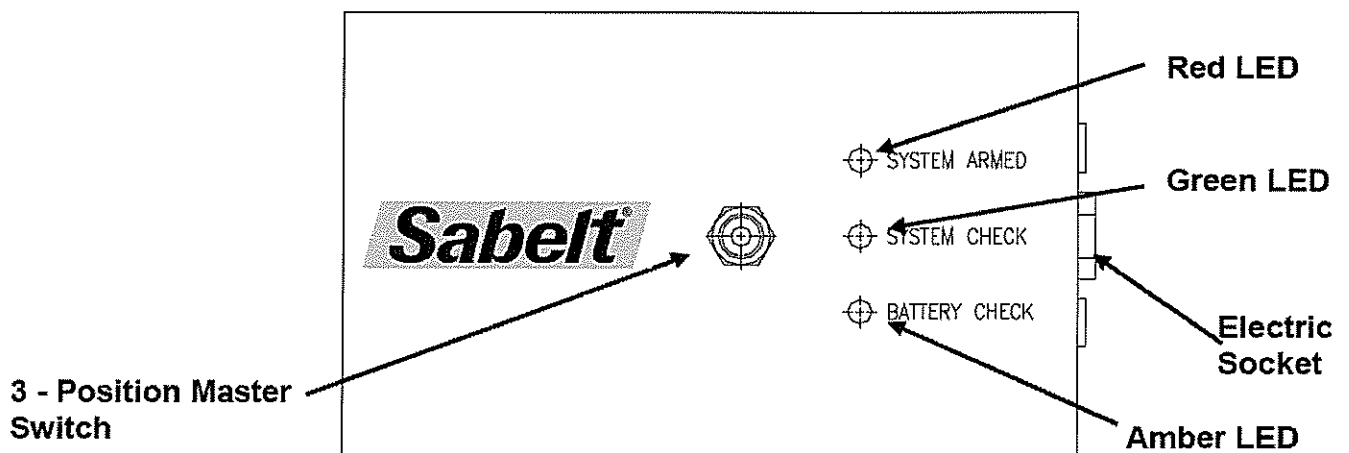

Electric Stored Pressure Systems

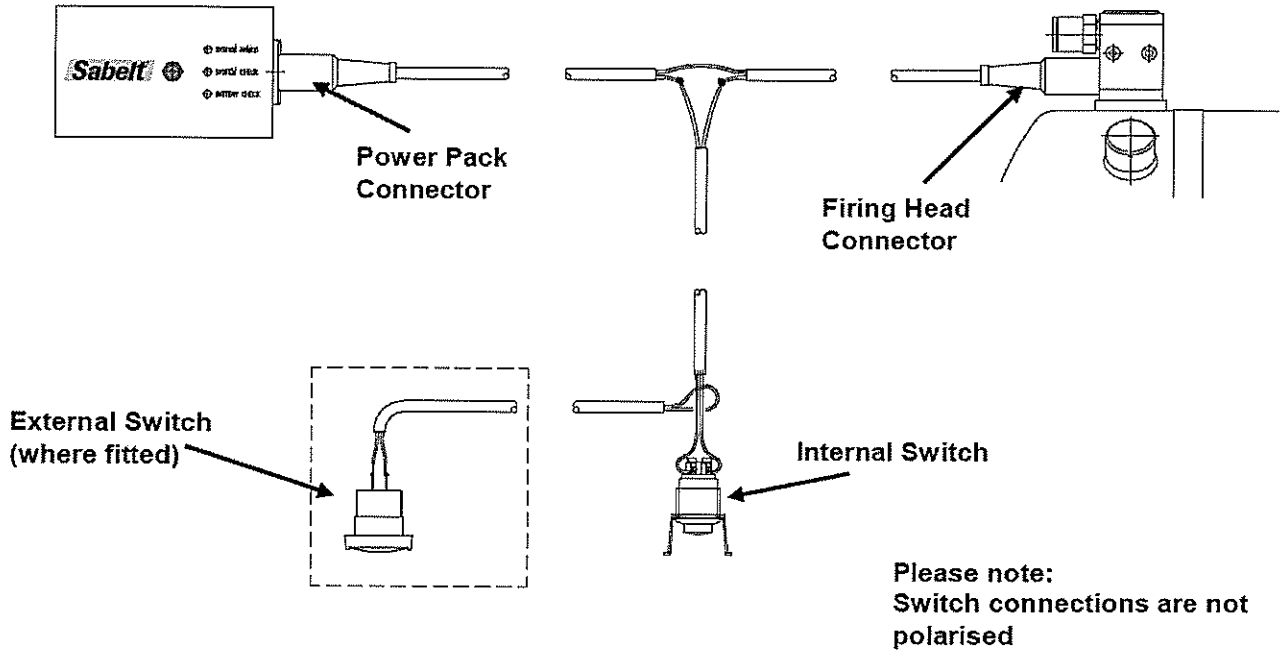

Remote Pressure Discharge Systems

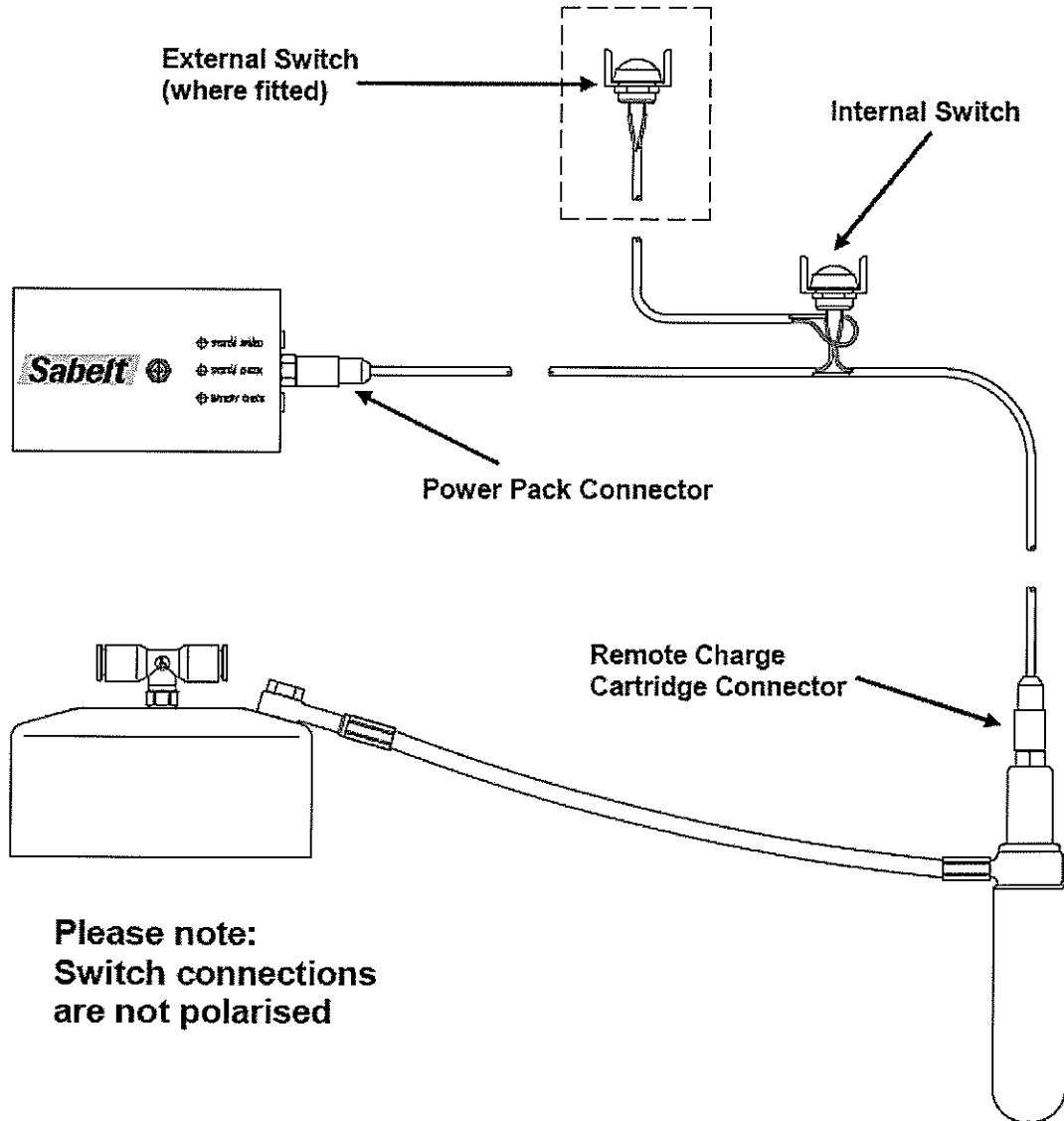

Nozzles

It is important that the correct nozzles supplied with the system are used. The nozzles will produce a flat 110° (Cockpit) spray pattern. The nozzles must be positioned so that the slot through the center axis of the outlet side of the nozzles is horizontal. See diagram below.

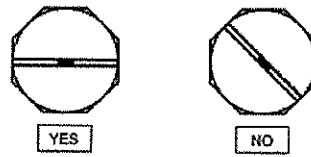

Sabelt nozzles are designed so that they can be mounted through a bulkhead or to a specially made bracket. Nozzles should be mechanically secured and not be simply supported by their own pipe work.

Cockpit Nozzle Location for Closed Cars

Two nozzles must be mounted in the cockpit area. We recommend that these are mounted so that they spray horizontally in to the foot well area of both the driver and passenger compartment. See figure below.

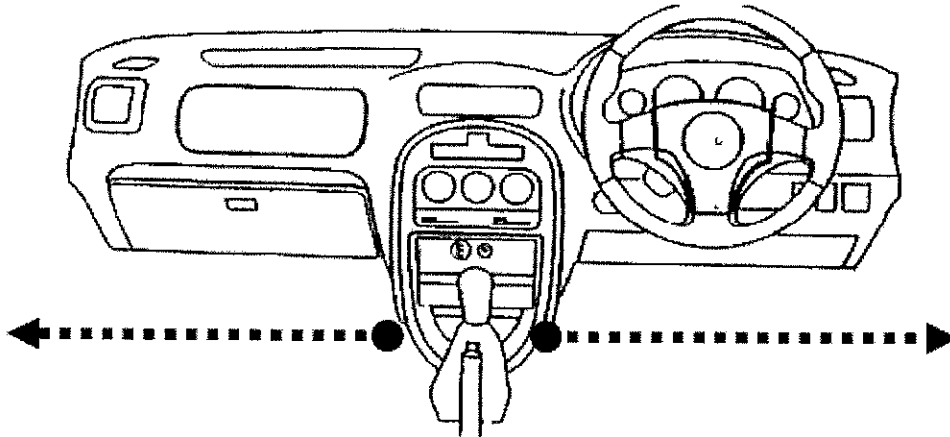

ARROWS DENOTE NOZZLE LOCATION AND DIRECTION ENSURE THE NOZZLES ARE ORIENTATED CORRECTLY

Cockpit Nozzle Location for open cars

Both nozzles should be mounted in the cockpit area of an open car. The nozzle should be aimed at the driver's midriff, in the normally seated position. Special care should be taken to ensure that the nozzle will not spray into the driver's face.

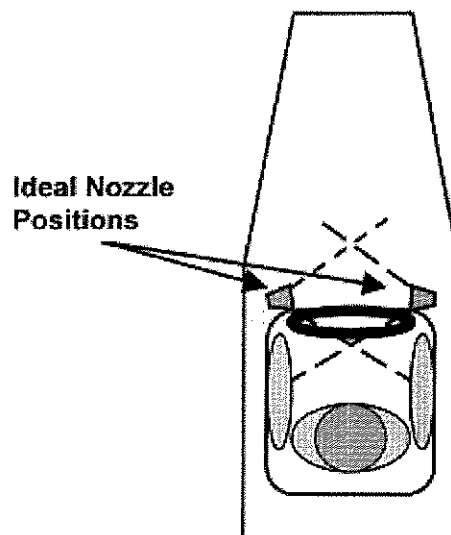

Engine Nozzle Location for both Open and Closed Cars.

Two nozzles must be mounted in the engine compartment. These nozzles spray all around the engine, ensuring full coverage. We recommend that the nozzles are mounted diagonally apart and at least 200mm below the bonnet shut line. See figure Below.

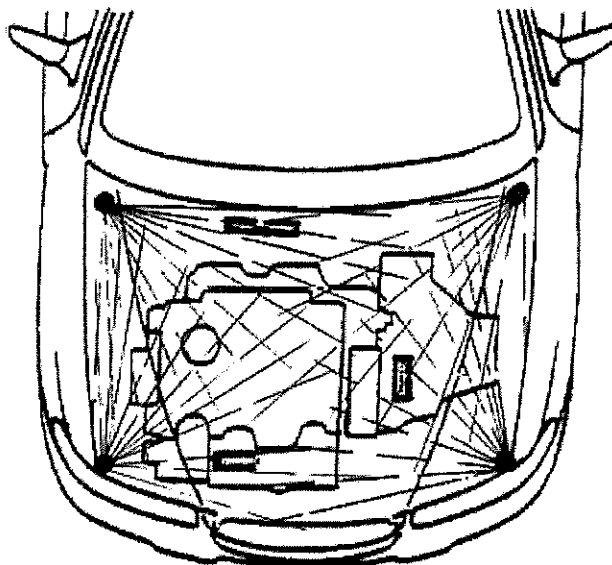

SUGGESTED NOZZLE LOCATIONS

3Kg Systems

These systems are supplied with additional nozzles. These can be positioned at the installer's choice of location, either to provide suppression at other risk areas such as fuel cell or high pressure hydraulic systems, or to supplement the nozzles in the engine compartment or cockpit.

Tubing

Each extinguisher kit is supplied with a roll of plastic coated aluminium tube and a roll of protective heat resistant over braid. We strongly recommend that you use this over braid as it will provide protection up to 450°C. The system has been designed and homologated to use this type of tube. Under no circumstances should the tubing be changed for another type.

Tube connections

To enable a simple installation, the extinguisher and nozzles use push-in fittings for the tube. To attach the tube to the fitting, ensure that the end of the tube is cut at 90° and that the outside diameter has retained its circular shape. Cutting tool P/N: LL991-101-001 is available from Sabelt. Insert the tube into the fitting, pushing firmly until it clicks. You should then be unable to pull the tubing back out of the fitting.

To remove the tubing, push the tube into the fitting and pull the black collar on the fitting in the same direction. Once this is done, pull the tube from the fitting.

Correct orientation of the T piece fitting (where supplied) is critical to the performance of your system. An example is shown here with the feed to the centre leg, and the outlet legs supplying the nozzles.

Remote Charge Systems – Checking that system has been activated

Remote charge systems are normally un-pressurised and therefore not supplied with a gauge. To check for contents or whether the system has been activated the following checks should be regularly carried out.

Weigh the cylinder and compare the actual weight to that stated on the cylinder label. If the weight is greater than 5% less than the weight indicated on the label the extinguisher should be taken out of service for repair.

Installation Kit Contents

2.25 kg Zero 360 Electrical Stored Pressure

- 1 Cylinder complete with operating head, bracket & straps.
- 1 941-000-001 Power pack
- 2 942-100-004 Waterproof Switch with aluminium bezel
- 2 943-101-001 Plug & lead assembly, Standard
- 8m 951-101-008 8mm Semi-rigid tube
- 8m 951-300-001 Overbraid, heat protective
- 4 952-408-001 8mm Equal T Connector
- 1 952-408-002 8mm Bulkhead fitting
- 6 955-300-003 Engine/Cockpit nozzle
- 2 951-200-004 Pipe clip, pack
- 1 990-100-001 Decal pack

TECHNICAL SPECIFICATION OF ZERO 360

USAGE	Racing, Touring and Rally cars - all groups
CONTENTS	3M™ Novec™ 1230 Fire Protection Fluid
DISCHARGE AREAS	Engine compartment and drivers compartment
DISCHARGE TYPE	The product is stored in a container and discharged through spray nozzles, as a liquid turning to gas on contact with fire.
COMPOSITION	Dodecafluoro-2-methylpentan-3-one, (CF ₃ CF ₂ C(O)CF(CF ₃) ₂)
O D P	(Ozone Depletion Potential) NONE
OPERATING TEMPERATURE	- 30 - + 60 °C
FREEZING POINT	- 108 °C
CRITICAL TEMPERATURE	168.7 °C
PHYSIOLOGICAL PROPERTIES	No Observed Adverse Effect Level and Lowest Observed Adverse Effect Level for cardiac sensitisation (halocarbons) and oxygen depletion (inert gas).

A copy of the 3M™ Novec™ 1230 Fire Protection Fluid material safety data sheet can be obtained from Sabelt upon written request.

MAINTENANCE

Sabelt has taken the greatest possible care in designing and manufacturing your fire suppression system. To ensure that you get the best possible performance from your Zero 360 system, the following checks and maintenance procedures should be carried out before the vehicle is used.

- Remote Charge Systems - Check the weight of the cylinder and compare with the weight written on the extinguisher label. If the actual weight is more than 5% less than the weight on the label return the extinguisher for checking.
- Pressurised Systems - Regularly check the pressure gauge indication is in the green sector.
- Check the integrity of the pipework and fittings
- Check the Zero 360 nozzles for no obstructions and foreign bodies
- Check the cylinder for signs of damage

Your Zero 360 system should be serviced every two years and system cylinders have a total service life of 10 years. A service due date is marked on the extinguisher label. It is your responsibility to ensure that the service is carried out at the correct intervals. Servicing of the extinguisher **MUST** only be carried out by Sabelt or one of its official agents. For remote charge systems you will need to return the cylinder together with the remote charge cartridge unit to be serviced.

If your Zero 360 system is discharged, it must be returned to Sabelt or one of its agents for refilling. Your Zero 360 system will be rejected from scrutineering if:

- The gauge reads in the Red sectors
- The tamper proof labels are not intact
- Non genuine Sabelt parts have been used
- The contents are below the specified weight
- The extinguisher label is worn or illegible
- The extinguisher is not within service date
- The system is in poor condition.

Annex - Systems Schematic Diagrams

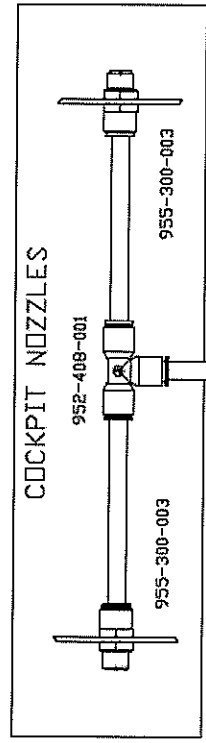
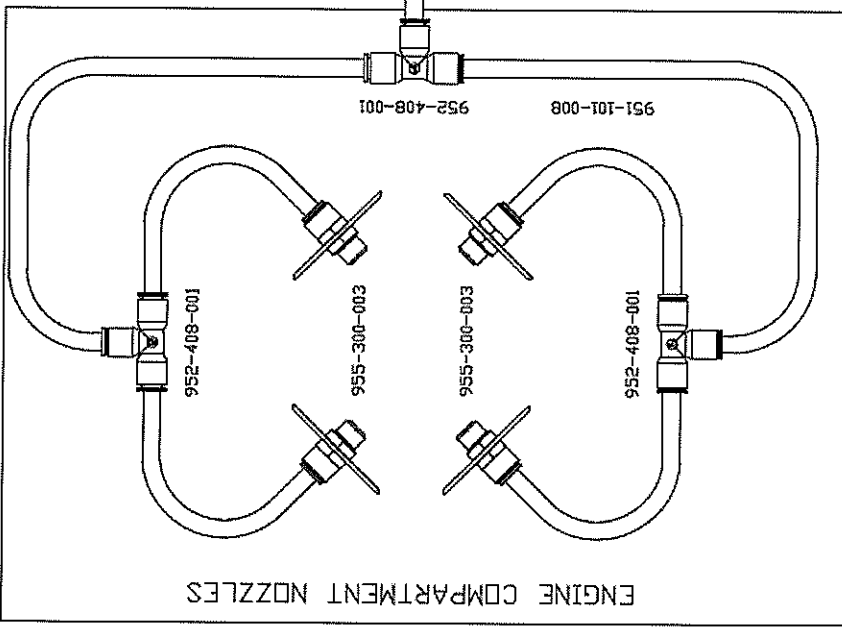

952-408-002

952-408-001

951-101-008

114-225-002

943-101-001

942-100-004

942-108-004

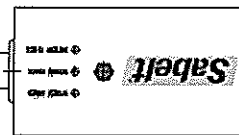

941-000-001

COMPONENT / TITLE	DRG. No.	104-225-002	ISSUE 1	SHT 1 OF 1	DATE	28,7,8	DRWN	MD	THIRD ANGLE PROJECTION AUTHORIZATION SIGNATURE Date 28,7,8	
	104-225-002, Zero 360 FIA 2.25kg Electrical									

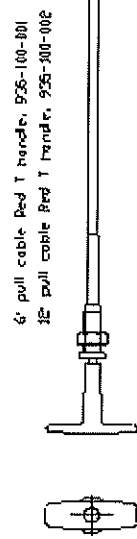
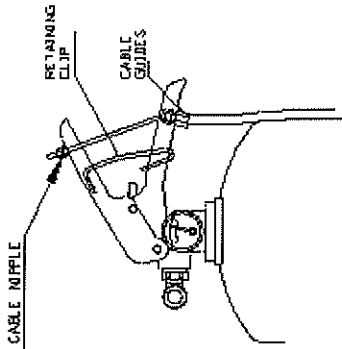
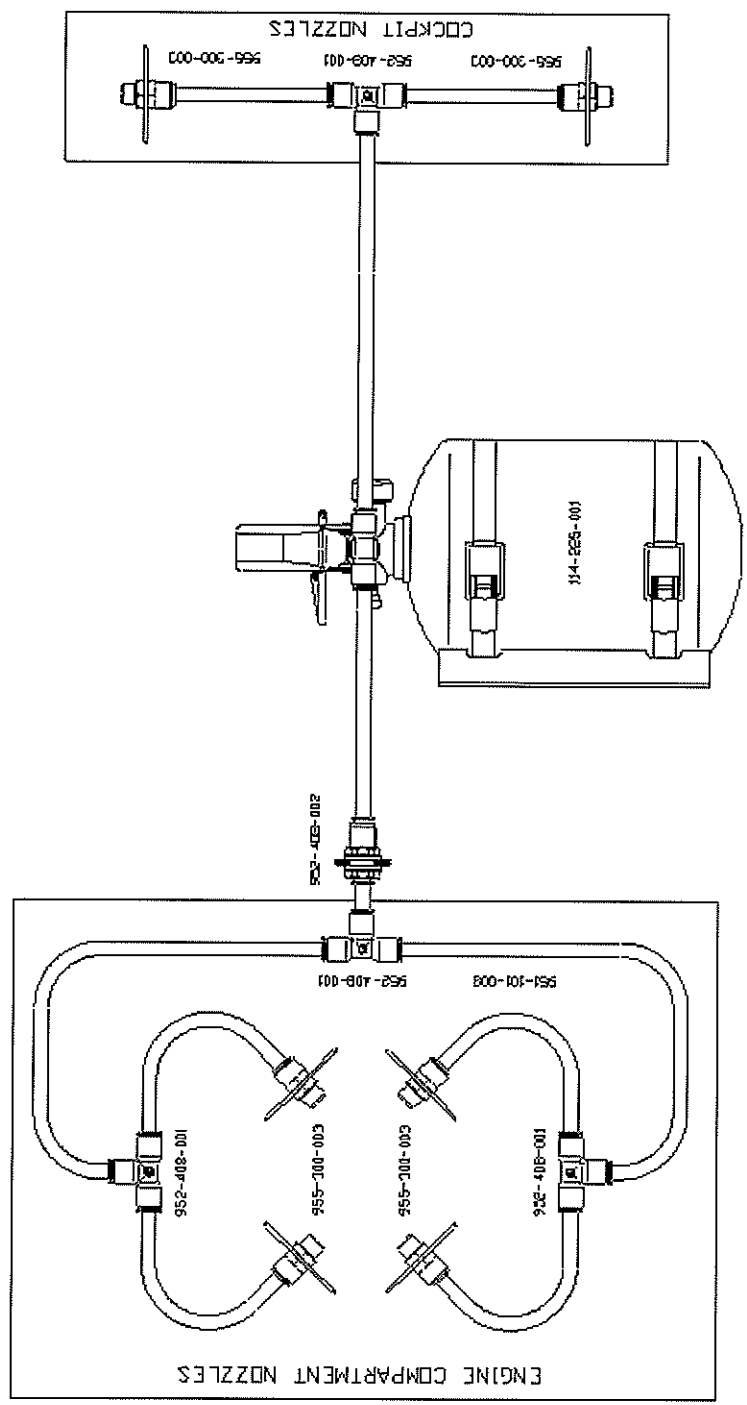

6" pull cable Red T handle, 925-100-001
 32" pull cable Red T handle, 925-100-002

COMPONENT / TITLE

ISSUE 1 SHT 1 OF 2

DATE 24.7.9

MD

DESIGNER

PROJECTION

ALUMINIUM SECTION

SIGNATURE

DATE 24.7.9

Solife 2.25kg Novoc Stored Pressure Mechanical - Aluminium Cylinder



Sabelt S.p.A.

Via Guido Rossa, 10

Moncalieri (TO) ITALY

Tel: +39 (0) 11 6477899 Fax: +39 (0) 11 6477999

Website: www.sabelt.com

Email: info@sabelt.com