

**1969**

**FIA**

**ANNEXE "J" AU CODE  
SPORTIF INTERNATIONALE**

**CLASSIFICATION, DEFINITION ET  
SPECIFICATIONS DES VOITURES**



**APPENDIX "J" TO THE  
INTERNATIONAL  
SPORTING CODE**

**CLASSIFICATION, DEFINITION AND  
SPECIFICATIONS OF CARS**

# APPENDIX J

## TO THE INTERNATIONAL SPORTING CODE

### 1969

#### Classification, Definition and Specifications of cars

---

*Specifications in italics are interpretations or explanations given by the CSI since the introduction of the present Appendix "J" in 1966*

#### TITLE I

#### CLASSIFICATION OF CARS

**Art. 251.—Categories and groups:** cars competing in events shall be distributed into the following categories and groups:

**Category A:** recognized production cars (numbers between brackets are those of the required minimum production in 12 consecutive months).

- Group 1 : series-production touring cars (5,000).
- Group 2 : touring cars (1,000).
- Group 3 : grand touring cars (500).
- Group 4 : sports cars (25).

**Category B:** special cars.

- Group 5 : special touring cars.
- Group 6 : prototype-sports cars.

**Category C:** racing cars.

- Group 7 : two-seater racing cars.
- Group 8 : formula racing cars.
- Group 9 : formula libre racing cars.

#### TITLE II

#### DEFINITIONS AND GENERAL PRESCRIPTIONS

**Art. 252.—Definitions a) Recognized production cars:** cars of which the series-production of a certain number of identical (see definition of this word hereafter) cars, has been completed within a certain period of time, and which are meant for the normal sale (see below) to the individual purchaser. This period of time is of 12 consecutive months. The checking of the existing minimum production enables the ACN to apply to the FIA for recognition (see this word below).

**b) Special cars:** cars which have nothing or which have no more to do with a series-production vehicle, either that only one of the type has been built, or that the number of units which has been built is inferior to what is required for the group for which the minimum number of units annually produced is the smallest, or that although they originate from a series-production car, they have been modified or equipped with new accessories to the point that their series-production nature has been lost.

**c) Racing cars:** cars manufactured solely for speed races on a circuit or a closed course. These cars are generally defined by the international racing formulae the specifications of which are fixed by the FIA for a certain period of

time. Racing cars not being defined by any international formula are said to be "formule libre" and their specifications must in that case be set out in the supplementary regulations of the event.

**d) Identical:** by "identical" cars are meant cars belonging to one and the same fabrication series and which have the same coachwork (outside and inside), same mechanical components and same chassis (even though this chassis may be amalgamated with the coachwork in case of a unitary construction).

"Mechanical components" include all parts for the propulsion, suspension, steering and braking system and all accessories whether moving or not which are necessary for their normal functioning (such as for instance, electric accessories).

By chassis is meant the structure of the car which holds mechanical components and coachwork together, and includes any structural part which is located below the horizontal plane passing through the centre of the wheel hubs.

**e) Minimum production:** this minimum production, different for each group of cars, applies to cars which are identical, the manufacturing of which has been fully completed within a period of 12 consecutive months.

**f) Normal sale:** means the distribution of cars to individual purchasers through the normal commercial channels of the manufacturer.

**g) Recognition:** is the official certification made by the FIA that a minimum number of cars of a specific model has been made on series-production terms to justify classification in group 1, 2, 3 or 4 of these regulations. Application for recognition shall be submitted to the FIA by the ACN of the country in which the vehicle is manufactured and shall entail the drawing up of a recognition form (see below). It must be established in accordance with the special regulations, called "Regulations for Recognition", laid down by the FIA, and a manufacturer wishing to obtain the recognition of his model(s) must undertake to abide by their prescriptions. Recognition will only be granted to car-models which were still in production on 1st January 1968 or the production of which was started after that date. Recognition of a series-produced car will become void 4 years after the date on which the series-production of the said model has been stopped.

Recognition of a model may only be valid for one group. The transferring of a previously recognized model from one group to another will therefore nullify the effect of the said previous recognition.

**h) Recognition forms:** all cars recognized by the FIA shall be the subject of a descriptive form called Recognition form on which shall be entered all data enabling identification of the said model.

To this effect only the standard recognition forms and standard additional form for "normal evolution of the type" and "variant" approved by the FIA shall be used by all ACNs.

The production of the forms at scrutineering and/or at the start may be required by the promoters who will be entitled to refuse the participation of the entrant in the event in case of non-production.

In case of any doubt remaining after the checking of a model of car against its recognition form, the scrutineers would have to refer either to the maintenance booklet published for the use of the make's distributors or to the general catalogue in which are listed all spare parts.

It will rest with the competitor to obtain the recognition form and, if need be, the additional forms concerning his car, from the ACN of the manufacturing country of the vehicle.

*Whenever the scrutinizing of a car shows the complete compliance of it with its recognition form, inasmuch as is required for the group in which it is admitted, there is no need to worry about its year of fabrication.*

**i) Cylinder-capacity classes:** the cars shall be distributed into the following 13 classes, according to their cylinder-capacity

1.	Cylinder-capacity inferior or equal to	500 cc							
2.	Cylinder-capacity exceeding	500 cc	and inferior or equal to	600 cc					
3.	"	"	"	600 cc	"	"	"	"	700 cc
4.	"	"	"	700 cc	"	"	"	"	850 cc
5.	"	"	"	850 cc	"	"	"	"	1,000 cc
6.	"	"	"	1,000 cc	"	"	"	"	1,150 cc
7.	"	"	"	1,150 cc	"	"	"	"	1,300 cc
8.	"	"	"	1,300 cc	"	"	"	"	1,600 cc
9.	"	"	"	1,600 cc	"	"	"	"	2,000 cc
10.	"	"	"	2,000 cc	"	"	"	"	2,500 cc
11.	"	"	"	2,500 cc	"	"	"	"	3,000 cc
12.	"	"	"	3,000 cc	"	"	"	"	5,000 cc
13.	Cylinder-capacity exceeding	5,000 cc							

Regulations intended for specific events may provide one or several sub-divisions of class 13. There shall be no sub-division of the other classes.

The above mentioned classification will apply only to non-supercharged engines.

Unless otherwise specified in special provisions set up by the FIA for a certain category of events, the organizers are not bound to include all the above mentioned classes in the supplementary regulations, and, furthermore they are free to group two or more consecutive classes, according to the particular circumstances of their events.

**j) Formulae of equivalence between reciprocating piston engines and special engines.**

**Rotary piston engines:** cars with rotary piston engines covered by the NSU-Wankel patents will be admitted on the basis of a piston displacement equivalence. This equivalence is twice the volume determined by the difference between the maximum and minimum capacity of the working-chamber.

**Turbine engines:** cars propelled by a turbine engine will be admitted on the basis of a formula of equivalence with regard to alternating piston engines. This formula is the following:

$$A = \frac{C \times 0.09625}{(3.10 \times R) - 7.63}$$

**A** = High-pressure nozzle area—expressed in square centimetres by which is meant the area of the air-flow at the exit from the stator blades (or at the exit from the first stage if the stator has several stages). Measurement is done by taking the minimum area between the fixed blades of the high pressure turbine first stage. In cases where the first stage turbine stator blades are adjustable, they will open to their greatest extent to present the greatest area for the determination of area "A".

The area of the high pressure nozzle is thus the product—expressed in square centimetres—of height by width and by the number of vane spaces.

**C** = Cylinder-capacity of reciprocating piston engine expressed in cubic centimetres.

**R** = The pressure ratio i.e. the ratio of the compressor of the turbine engine. This pressure ratio is obtained by multiplying together a value for each stage of the compressor, as indicated hereafter:

Subsonic axial compressor = 1.15 per stage.

Trans-sonic axial compressor = 1.5 per stage.

Radial compressor = 4.25 per stage.

Thus a compressor with one radial and six axial stages will be designated to have a pressure ratio of:

$$4.25 \times 1.15 \times 1.15 \times 1.15 \times 1.15 \times 1.15 \times 1.15 \text{ or } 4.25 \times 1.15^6.$$

The CSI reserve their right to modify the basis of comparison established between conventional type engines and new type engines, while giving a previous notice of one year to start from January 1st, following the date on which the decision was made.

**k) Supercharging:** if the engine of a car includes a separate device used for supercharging it, the nominal cylinder-capacity will be multiplied by 1.4 and the car will pass into the class corresponding to the fictive volume thus obtained. The new cylinder-capacity of the car shall always be considered as the real one. This shall particularly be the case for assigning the car to its cylinder-capacity class, and the car will be treated in all respects as if its cylinder-capacity thus increased was its real capacity. Especially in regard to its classification per cylinder-capacity class, its inside dimensions, its minimum number of seats, etc.

A dynamic air inlet for ducting the air from the atmosphere into the engine intake will not be considered as a supercharging device.

**l) Coachwork:** by coachwork is meant:

- externally: all parts of the car licked by the air-stream and situated above a plane passing through the centre of the wheel hubs.
- internally: all visible parts of the passenger compartment.

Coachworks are differentiated as follows:

- 1) completely closed coachworks,
- 2) completely open coachworks,
- 3) convertible coachworks: with a hood in either supple (drop-head) or rigid (hard-top) material.

Coachworks of one same minimum series shall be identical with the only exception of a "sun roof".

However, if a model has its coachwork equipped with a specific number of doors and has been recognized on the basis of a given minimum series, similar recognition may be granted to another coachwork with a different number of doors when its minimum production reaches 50% of the figure necessary for recognition of the basic series, providing that both models have the following common characteristics:

- 1) a coachwork of similar shape, i.e. of which the general appearance is basically the same and which has not been modified beyond what is necessary to change from a four door version to a two door version (or vice-versa);
- 2) exactly identical mechanical parts;
- 3) the same wheelbase, track and number of seats;
- 4) at least the same weight;
- 5) an FIA decision to recognize this variant coachwork and to draw up an additional "variant" recognition form.

As far as convertible cars are concerned, these must comply in all respects with the specifications applying to closed cars if they run an event under this form, or with the specifications concerning open cars if they run with the hood down or the hardtop removed.

**m) Minimum weight:** is the real minimum weight of the empty car (without persons or luggage aboard) fully equipped and ready for delivery to the purchaser. It shall consequently include a spare-wheel equipped with a tyre similar to those mounted on at least 2 of the 4 wheels, and none of the accessories normally mounted on the least expensive model of the series concerned being removed, except for the normally supplied repair kit (jack, tool-kit). All liquid tanks (of

lubrication, cooling system, braking, heating system, if need be), except for the fuel tank, must be full.

The minimum weight of the car mentioned on the recognition form shall be strictly respected. Any lightening of the car by removal or replacement of parts, aiming at reducing its weight, is prohibited.

*It is specified that the minimum weight indicated on the recognition form is that of the car as it is described in the basic recognition form.*

*Additional equipment and instruments (revolution counter, tool kits, roll-bar, extra lamps, etc.), whether recognized or not as variants for the model concerned, and fitted on the car for use in certain types of competition, cannot be considered as included in the minimum weight indicated on the recognition form.*

*During a verification of the weight of a car, the said equipments or instruments must therefore be removed from the car. If, for practical reasons, such a removal proves to be difficult, it is recommended that the promoters require the entrants to supply a detailed list of all additional equipments and instruments fitted on the car, with indication of their respective weights. For the technical verification, these weights must then be added to the basic minimum weight indicated on the recognition form concerned.*

### **Art. 253.—Prescriptions common to all cars of categories A and B.**

**a) Chassis, ground-clearance, steering lock:** the car, supplied with enough fuel for starting the event, its oil and water tanks full, must be able to drive over—under the power of its engine and with its driver at the steering-wheel—a mass of 80×80 cm and 10 cm high.

The maximum steering radius shall be 6.75 m which means that the car must be able to make a complete turn in both directions without the wheels going beyond two parallel lines drawn on the ground 13.50 m apart.

**b) Coachwork:** minimum inside dimensions and minimum number of seats: cars shall be equipped with a minimum of two seats or a minimum of four seats according to the group in which they seek recognition and, within a same group, according to their engine cylinder-capacity.

For each group specified in these regulations, the minimum number of seats is listed hereafter and the minimum inside dimensions for both cases are indicated in the following paragraphs.

**1st case** (see diagram 1): car equipped with 4 or (more) seats.

The height at the front (B) is measured between the lowest point of the front seat cushion compressed by a standard mass of 60 kgs (see diagram 2) and the ceiling (the padding if any, may be compressed). Should the backrest of the front seat(s) be inclined backwards, the protected height must also be measured at the same angle as the inclination of the backrest.

— If the front seats are separate, the measurement is made in the middle of the two seats. In case of adjustable front seats, the seats will be placed in medium position.

— If there is a common front seat, the measurement is made at 25 cm from the centre line of the car.

The height at the back (D) is measured between the cushion of the rear seat, compressed by the standard mass, and the ceiling (the padding if any, may be compressed) at 25 cm from the centre line of the car. Should the backrest of the rear seat be inclined backwards, the protected height must also be measured at the same angle as the inclination of the backrest.

The width over the front seats (C) is measured along the vertical plane passing through the centre of the standard mass, 30 cm above the compressed seat, and between the upper strip of each front door.

The width over the back seats (E) is measured along the vertical plane passing

through the centre of the standard mass, 30 cm above the compressed seat and between the upper strip of each back door, or at the same height as for the front seats when there are no rear doors.

The minimum dimensions (in centimetres) are the following:

Cylinder-capacity	B	C	D	E
Up to 700 cc	85	100		
From 700 to 2,000 cc	85	110	85	110
Over 2,000 cc	90	120	85	120

Moreover, in order to be considered as a four-seater, a model must fulfill certain conditions regarding its rear-seating capacity. These conditions are the following (see diagram 3):

- 1.— l must be at least 90% of L;  
m must be at least 85% of M;  
n must be at least 80% of N;  
p must be at least 80% of k+m.

- 2.— k must measure at least 15 cm and the minimum measures for the foot-space of the rear passengers must be: 32 cm long, 5 cm high and (for each one of the two passengers) 25 cm wide.

- 3.— the space available for the rear passengers must meet the following condition:  $k+l+m=95$  cm minimum.

- 4.— cars in which the back of the rear seat(s) is inclined forward beyond the vertical cannot be considered as four-seaters.

The measuring of the above dimensions must be carried out under the following conditions:

- the front seat, if adjustable, must be placed in its normal driving position, i.e.:  $K+L+M$  must measure at least 120 cm.

- if the front seats have reclining backrests, these should be set at an inclination of 15° backwards.

- K is measured horizontally from the brake pedal (at rest) to the foremost point of the front seat; k is measured horizontally at a height equal to l) from the back of the front seat to the foremost point of the rear seat.

L and l are measured vertically from the highest point of the cushion of the seat to the floor of the car. At the front L must be measured at the usual resting-place of the driver's heels.

M and m are measured horizontally from the foremost point of the seat to the backrest to be measured at a height of L (l).

Two specific cases must be distinguished:

- 1) bucket-seats: the measuring must be taken on the centre line of each seat.
- 2) common seat: measuring must be carried out at 25 cm from the longitudinal axis of the vehicle.

However, for the rear seat(s) measuring must be made in the same vertical plane as for the front seats.

N (and n) are measured vertically from the highest point of the backrest to the highest point of the cushion of the seat.

p is measured (in the same vertical plane as m) horizontally from the rearmost point of the backrest of the front seat to the backrest of the rear seat.

For the above-mentioned measurements, seats must not be occupied.

**2nd case** (see diagram 4 and 5): cars with a minimum of 2 seats.

The two seats must be distributed equally on either side of the longitudinal centreline of the car and at the same level, regardless of their normal play for adjusting them to the size of the driver. The location provided for placing or

housing the seats must have a minimum width of 40 cm maintained all along the depth of the seat.

The "protected height" shall be at least 80 cm measured from the cushion of the seat compressed by the standard mass (see diagram 2) to the ceiling (any existing padding being compressed) in cars with closed coachwork and 80 cm from the surface of the seat compressed by the standard mass (see diagram 2) to the upper edge of the windscreen (measured vertically through the centre of the standard mass) in case of open cars.

The minimum interior width over the front seats (see measurement C) shall be of 100 cm in cars with a cylinder-capacity inferior or equal to 700 cc, 110 cm in cars with a cylinder-capacity from 700 cc to 2,000 cc and 120 cm in cars with a cylinder-capacity exceeding 2,000 cc. The minimum width of foot-space (for each person) must be at least 25 cm measured perpendicularly to the centreline of the car, plumb with the pedals.

**c) Windshield—Windshield wiper:** a windshield made of safety glass is compulsory. In all production cars it shall be made of the material originally provided by the manufacturer. It shall be equipped with at least one automatic wiper sweeping a sufficient area to enable the driver to distinctly see the road from his seat.

The windshield shall comply with the following requirements:

- 1) be placed symmetrically with regard to the centreline of the car,
  - 2) have a minimum height of 25 cm, maintained between two points symmetrically placed with regard to the centreline of the car and of which one is determined by the vertical line passing through the centre of the steering-wheel. There must furthermore be at least 45 cm between the two said points,
  - 3) have a minimum width of 90 cm; chord measured at half its vertical height.
- Shall be considered as being the windshield, only the glass area through which one has an entirely free vision towards the front, without being limited by any outside opaque projection apart from the bulge of the mudguards which cover the front wheels.

**d) Mudguards:** shall be of permanent nature and firmly fixed.

They shall project over the wheels and provide efficient covering of at least one third of their circumference, and at least the width of the tyre.

In those cars where mudguards are entirely or partly overhung by the body structure, the combination mudguards-body or the body alone shall nevertheless meet the above protection requirements.

Mudguards must be solid with the body, there being no gap between them.

**e) Hood:** open or convertible cars shall be equipped with a hood fitting exactly, and without any intermediary device, to the windshield the door windows or side panels, and the rear of the coachwork.

The hood may not interfere with the opening of the doors. It shall include a rear window, the minimum dimensions of which are specified in the present article (see below "rear view").

It must be capable of being used during all or part of the event. The supplementary regulations may specify in which state convertible body cars must run (as closed cars or open cars, otherwise it shall be at the discretion of the entrant) but the hood if not fitted on the car must always remain aboard the car during the whole of the event. The hood may be replaced by a hard top subject to the same conditions as for a hood.

**f) Doors:** all vehicles shall be fitted with at least one rigid door on each side, with closing devices and hinges which may not be located on the rear-door post, nor on the door-sill. The dimensions of the lower door panel (the part which is



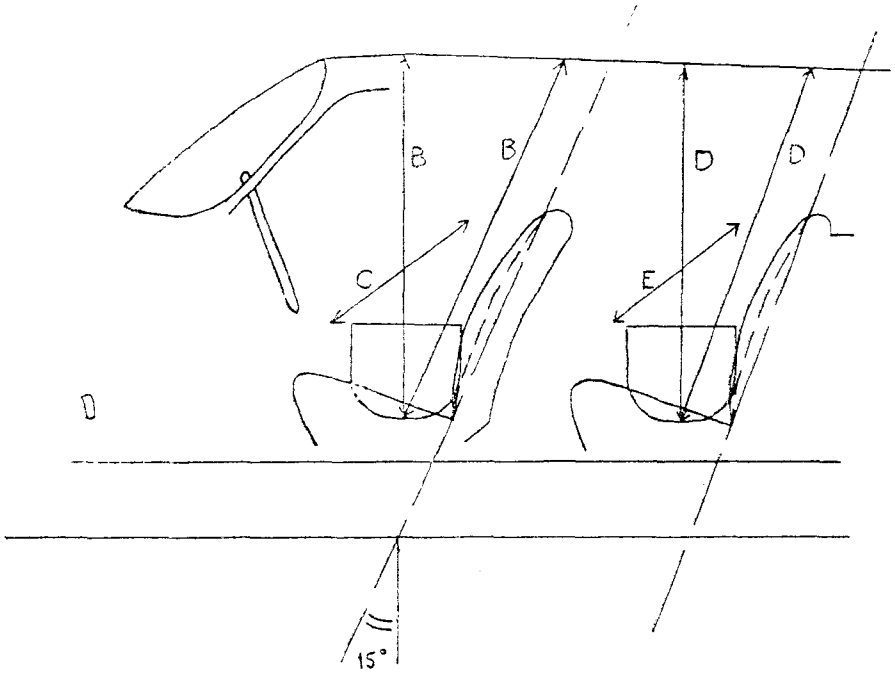

**Dessin/drawing No. 1**

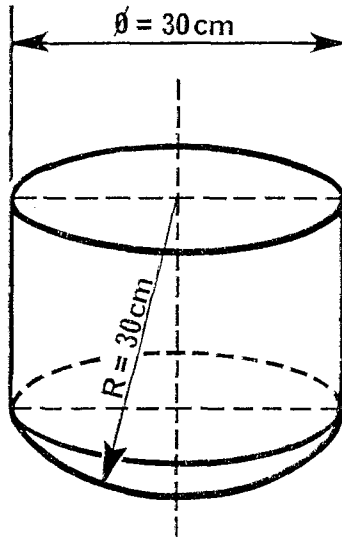

**Weight/tare = 60 kgs  $\pm$  200 grms.**

**Dessin/drawing No. 2**

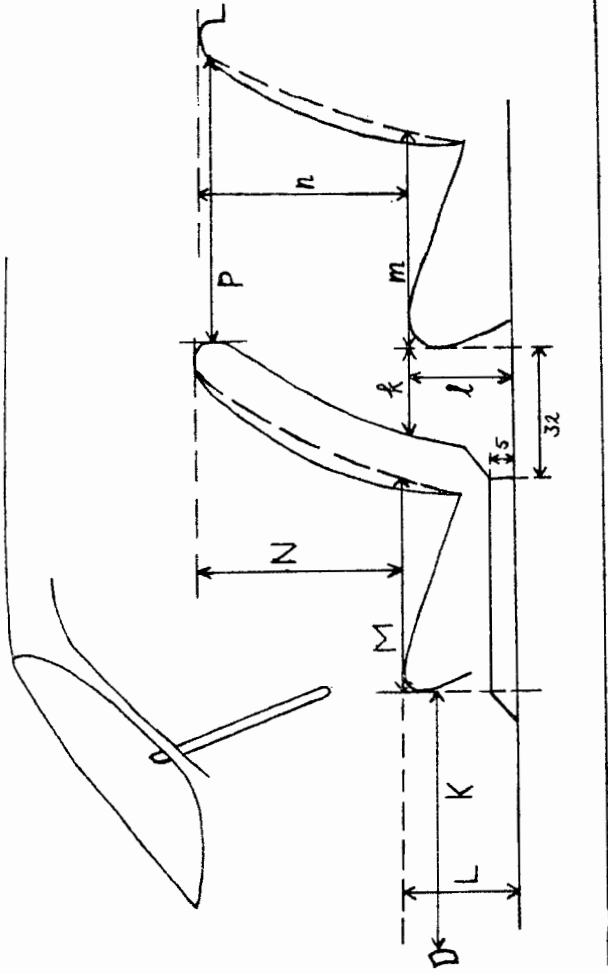

Dessin/drawing No. 3

**Largeur sur laquelle la "hauteur protégée" doit être maintenue**  
**Width where the "protected height" must be maintained**

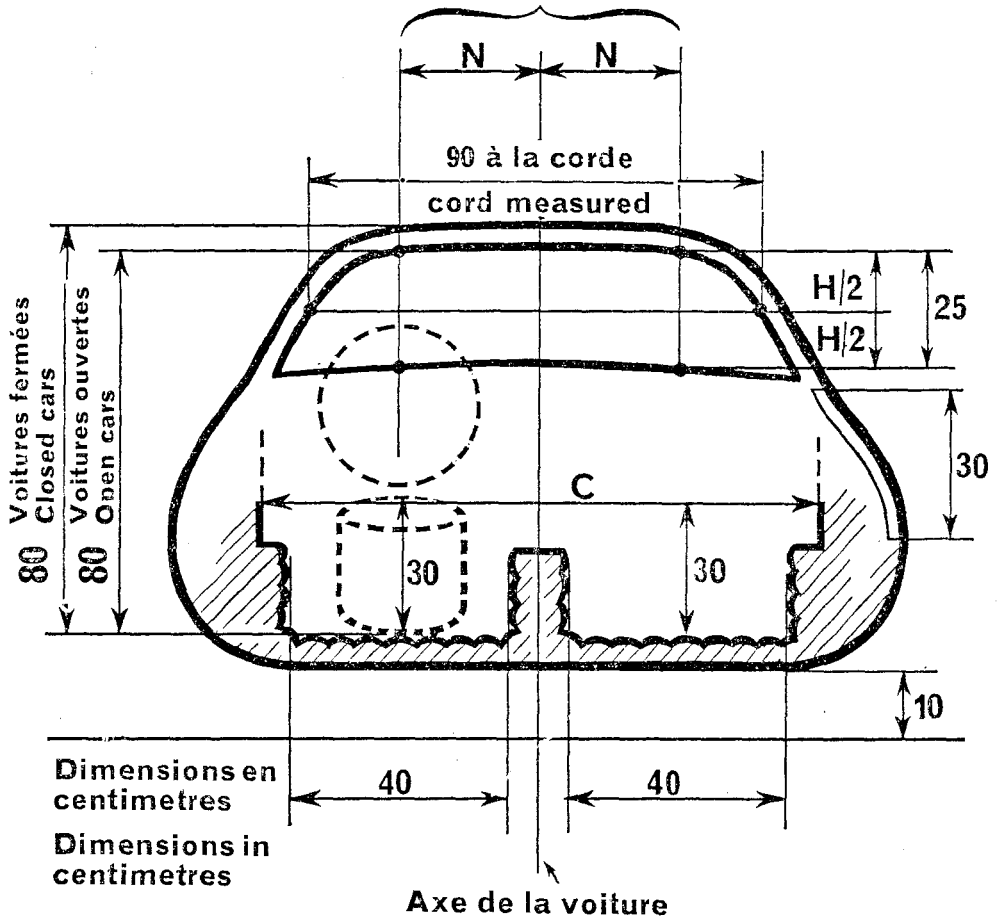

$N = N$

$N + N = 45 \text{ cm min}$

**Axe de la voiture**  
**Centre line of the car**

**Dessin/drawing No. 4**

	0-700 cc	700- 2,000 cc	2,000+ cc
C	100	110	120

En dessous de 20° retro-  
viseur extérieur  
obligatoire

Under 20° rear view  
mirror compulsory

80 Voitures ouvertes  
80 Open cars

80 Voitures fermées  
80 Closed cars

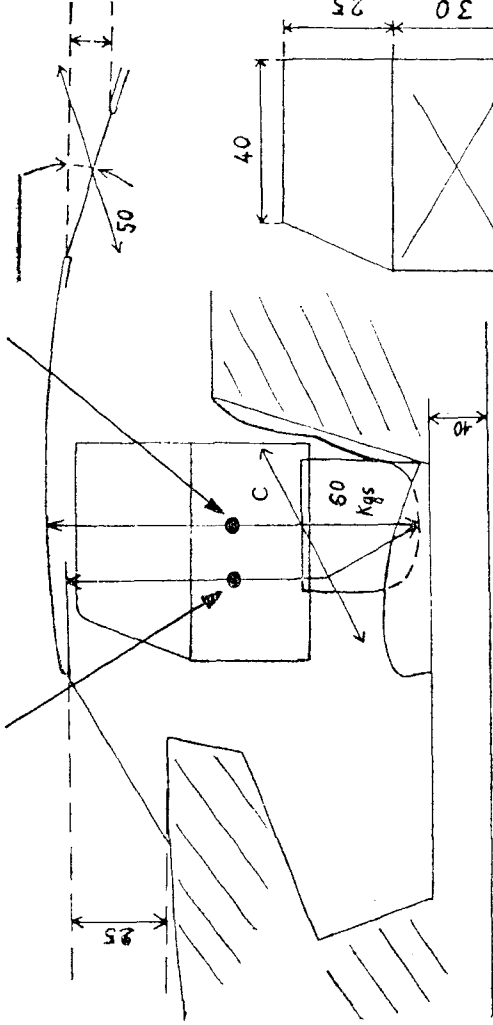

Dimensions en  
centimetres  
Dimensions in  
centimetres

Dimensions portière  
Door dimensions

Dessin/drawing No. 5

normally opaque) must be such as to allow a rectangle of at least 50 cm wide and 30 cm high being inserted in it. The corners of this rectangle may be rounded to a maximum radius of 15 cm. Cars with sliding-doors will not be allowed unless they include a safety system enabling a quick and easy evacuation of the car's occupants in case of an accident.

Cars with closed or convertible coachwork shall have doors equipped with moveable windows of the material provided by the manufacturer for the considered model, liable to be opened over at least one third of their surface in order to provide for ventilation, each window having a minimum width of 40 cm and a minimum height of 25 cm.

When opened, the doors must give free access to the seats. They must be made in such a way that they never restrict the lateral view of the driver.

*By doors should be understood the part of the coachwork opening to give access to the seats.*

**g) Rear view:** this shall be provided by an inside mirror commanding a rear window measuring at least 10 cm vertically maintained along a width of at least 50 cm. However, if the straight line connecting the upper and lower edges of the rear window opening makes an angle inferior to 20° with the horizontal, when the car complies with the same specifications as those required for checking the ground-clearance (see art. 253), the rear view must be efficiently obtained by other means (two outside mirrors or any other system of equivalent efficiency).

**h) Luggage trunk:** a covered space shall be provided which is an integral part of the coachwork but outside the space occupied by the passenger seats.

This space shall be such as to enable to carry without special difficulty a number of suit-cases, sheltered from rain or dirt which varies according to the cylinder-capacity of the engine equipping the car (see below), of the following minimum dimensions: 60 cm×40 cm×20 cm.

Cylinder-capacity inferior or equal to 2,000 cc: 1 suit-case,

Cylinder-capacity superior to 2,000 cc: 2 suit-cases.

However, in cars having inside dimensions which are inferior to the minima laid down in article 253 b to allow classification as a four-seater, but which contain a compartment behind the front seats liable to receive passengers, this compartment may be taken into account as luggage space whether or not it has been equipped for this purpose but without modifying any of the original parts.

**i) Starting:** cars must be equipped with a device and its source of power for automatically starting the engine and able to be actuated by the driver sitting at the wheel.

**j) Fuel tanks:** the total capacity of the fuel tanks (main and additional) must not exceed the following limits:

Cars up to 700 cc of engine cylinder-capacity : 60 l.

Cars from 700 cc to 1,000 cc cylinder-capacity: 70 l.

„ „ 1,000 cc to 1,300 cc „ „ : 80 l.

„ „ 1,300 cc to 1,600 cc „ „ : 90 l.

„ „ 1,600 cc to 2,000 cc „ „ : 100 l.

„ „ 2,000 cc to 2,500 cc „ „ : 110 l.

„ „ 2,500 cc to 3,000 cc „ „ : 120 l.

„ „ 3,000 cc to 5,000 cc „ „ : 140 l.

Cars exceeding 5,000 cc „ „ : 160 l.

Will be considered as a fuel tank any container holding fuel which can flow out by any method either to the main-tank or directly to the engine.

The filling-port(s) (and vents) of each tank must always be outside the passenger-compartment and be entirely leak-proof.

## **Safety type fuel tanks**

*The FIA has followed with great interest the introduction on the car accessory market of safety type fuel tanks, generally in the form of a tank in normal sheet steel with a layer of rubber inside (so called "bladder" type tanks) but sometimes also entirely made of synthetic material.*

*In order to promote the use of these tanks which are a considerable improvement in the drivers' safety, and to avoid any kind of administrative complications (conformity of the cars with their recognition forms, etc.), the use of safety type fuel tanks will be allowed and even recommended for all groups of cars of Appendix J and in all motor sport events.*

*Nevertheless, for cars of groups 1, 2 and 3 of Appendix J, the fitting of safety tanks will be allowed only if the manufacturer of the car has recognized them as such and provided they do not exceed the capacity of the original tanks as stated on the recognition form.*

**Location of fuel tanks:** *The emplacement foreseen by the manufacturer for the fuel tank(s) and the feeding system towards the engine, constitutes one of the principles of series-production, and this implies that no change can be made, unless an authorization is explicitly stated in Appendix J.*

*However, a derogation to the above rule shall be made for cars in which the manufacturer has placed the fuel tank inside the passenger compartment, and close to the occupants.*

*In this specific case, and for the sake of safety, it will be possible, whatever the group of cars, to mount a leak-proof protective barrier between the tank and the passengers, or to change the place of the tank and, if necessary, its accessory parts (filling port, petrol pump, outlet tube).*

**k) Spare-wheels:** all cars shall be equipped with at least one spare wheel with its tyre occupying the position provided for by the manufacturer which may not encroach upon the space provided for luggage.

The spare wheel must be equipped with a tyre of the same dimensions as those fitted on at least two wheels of the car.

**l) Silencer (muffler) and exhaust system:** even when the specific provisions for a group allow replacement of the original muffler, cars competing in an open road event shall always be equipped with an exhaust muffler complying with the road regulations of the country(ies) through which the event is run.

For events run exclusively on closed circuits, the supplementary regulations may authorize modification, replacement or removal of the exhaust muffler.

The outlet pipes of the muffler shall be directed either rearwards or sideways. If the outlet pipes are pointing rearwards, their orifices shall be placed at a height neither superior to 45 cm nor below 10 cm; they shall not protrude by more than 15 cm beyond the overall length of the car. If the exhaust pipes are directed sideways, their orifices must be located aft of a vertical line passing through the wheelbase centre and may not project in any way beyond side of the coachwork. Adequate protection shall be provided in order to prevent heated pipes from causing burns.

**m) Safety devices:** for cars competing in events which are speed races exclusively the following safety devices are foreseen:

1st) for cars with an open coachwork: compulsory fitting of a roll bar being 3 cm higher than the driver's helmet and being wider than the driver's shoulders when seated at his wheel;

2nd) for cars with a closed coachwork: optional fitting in of a roll cage improving the rigidity of the body and meant to prevent it from crushing in the

event of a violent shock or a somersault. This roll-cage must be mounted in such a way that:

- it shall in no way interfere with access to the seats and normally occupying them;
- it shall not encroach on the volume reserved for the driver or any of the passengers;
- the exact weight of the device shall be subject to a statement from the competitor, to be appended to the entry form. This weight must be added to that indicated for the vehicle on the recognition form.

The fitting of the above mentioned safety devices, which is mandatory for speed events (open cars), is authorized and even recommended for regularity trials.

**n) General circuit breaker:** all cars participating in speed races on closed circuits or in hill-climbs must be equipped with a general electric circuit breaker, which must be clearly marked. Closed cars must be fitted with two circuit breakers, one in the driver's compartment and one outside the vehicle in an easily detectable location. The fitting of such circuit breakers which is compulsory for speed events on circuits and hill-climbs is authorized and even recommended for rallies.

**o) Oil catch tank:** when cars are running in events which are only speed races on closed circuits, they must be equipped in such a way as to prevent oil from spilling on the track. In cars of a cylinder-capacity inferior or equal to 2,000 cc, the oil catching device shall have a minimum capacity of 2 litres and of 3 litres for cars with a cylinder-capacity exceeding 2,000 cc. This provision, mandatory for circuit speed events, will be optional for the other events (hill-climbs, rallies, even those including classification tests run on closed tracks) unless required by the supplementary regulations.

**p) Minimum lighting equipment:**

- for speed events on closed circuits and for hill-climbs, cars must be equipped with two "Stop" lights. In addition for events run during the night, cars must be fitted with at least two headlights as effective as those normally fitted on FIA homologated Touring or Grand Touring cars and two direction indicators mounted at the rear.
- for events run on open roads (rallies), cars must comply with the legal requirements of the country of the event; cars from other countries must comply in this respect with the Convention on international road traffic.

**q) Limits of authorized modifications:** certain modifications to the original parts, certain additions and/or removal of accessories normally mounted by the manufacturer of the model concerned, are explicitly authorized by the present regulations. The limits of these modifications are set out for each of the 6 groups of categories A and B. All those not explicitly mentioned as permissible for the group in which the car claims classification and which affect, even secondarily, the mechanical efficiency of the engine, the steering, the transmission, the road-holding and/or the braking, will imply the exclusion of the car from its group.

If these modifications or additions have been the subject of a previous statement by the entrant, the car may be allowed to compete in the event in one of the other groups provided in the supplementary regulations and with the prescriptions of which it complies. Should there be however an obvious case of wilful misrepresentation, the entrant should not be authorized to start or should be stopped if he had already started, with request to the ACN concerned to pronounce his suspension for at least 12 months.

**r) Fuel:** for speed races on circuit and hillclimbs: the fuel defined under Art. 297 hereafter. For rallies: a commercial fuel freely sold in the country(ies) traversed by the event. If in one of the countries the standards of the best com-

mercial fuel are inferior to the fuel having the lowest octane number in one of the three following countries: France, Great Britain, Italy, a special waiver may be granted to the promoters with the approval of the CSI.

Upper-cylinder or two-stroke engine lubricants are authorized on condition there is no increase of the fuel octane number.

**s) Application of general prescriptions:** the general prescriptions must be complied with if the particular specifications of groups of cars of categories A and B do not mention them or do not provide for any stricter prescription.

**Art. 254.—Rule for changing from one group to another and authorized amalgamation of groups:** cars originally belonging to a certain group but which have been subject to duly declared modifications and/or additions that exceed the limits specified for the group concerned, may pass into a higher group, provided for in the supplementary regulations, with the prescription of which it complies and under the following conditions:

- Group 1 passes into group 2.
- Group 2 (or 1+2) passes into group 5.
- Group 3 passes into group 4.
- Group 4 (or 3+4) passes into group 6.
- Group 6 (or 3+4+6) passes into group 7.

## TITLE II

### SERIES PRODUCTION TOURING CARS

**Art. 255.—Definition:** touring cars built on large series production terms. These cars shall compete in an event without having undergone any preparation likely to improve their performances or their conditions of use. The only working authorized is normal maintenance or the replacement parts damaged through wear or accident and the modifications and additions explicitly authorized hereafter under article 257. Except for what is explicitly authorized any part damaged through wear or accident may only be replaced by an original part which must be exactly the same as the one for which it is substituted.

**Art. 256.—Minimum production and number of seats:** series-production touring cars shall have been manufactured in a quantity of at least 5,000 identical units and offer at least 4 seats, except if their engine cylinder-capacity is inferior or equal to 700 cc. In which case the manufacturer may deliver them as two-seaters.

**Art. 257.—Mountings and modifications authorized :**

**a) Lighting devices:** all lighting and signalling devices must comply with the legal requirements of the country of the event; cars from abroad must comply in this respect with the Convention on international road traffic.

Lighting devices which are part of the standard equipment must remain those foreseen by the manufacturer and must comply as far as is concerned their functioning with what the manufacturer has foreseen for the considered model. Thus, if changing from a road beam to a passing beam is produced by merely deflecting the beam inside one same reflector, this system may not be altered.

Freedom is granted with regard to the frontal glass, the reflector and the bulbs.

It is permitted to add at the front only two lighting devices in addition to those normally provided by the manufacturer and mentioned on the recognition form.

The mounting of reverse-lights is authorized provided police regulations are respected but not the fitting of manoeuvrable search-lights on the roof or elsewhere.



Waivers may be granted to these specifications on condition that they be explicitly provided for in the supplementary regulations of the event.

The mounting of additional headlights shall not entail any modification of the coachwork.

The fitting of reverse-lights is authorized, if necessary by embedding into the coachwork, but provided it will only switch on when engaging the reverse-gear.

*To comply with legal requirements of certain countries, it is permissible to re-arrange the casing of front signalling devices in order to house both traffic indicators and parking lights.*

**b) Fuel and oil tanks :** must be those normally provided by the manufacturer for the model concerned, the capacities of which are specified on the recognition form. If, for the same model, tanks of different capacities are normally provided, only those mounted on the required number of cars necessary for recognition will be authorized.

The location and type of filling port for the fuel tank(s) may not be changed.

The use of a fuel tank with a larger capacity may be authorized by the ACN with the FIA's agreement, in the case of events organized under particular climatic conditions (on desert or tropical courses for instance).

**c) Cooling circuit :** if, for the same model, radiators of different capacities are normally provided, only those mounted on the required number of cars necessary for the recognition will be authorized. The addition of a radiator screen is authorized.

The use of a radiator with a larger capacity may be authorized by the ACN with the FIA's agreement, in the case of events organized under particular climatic conditions.

Make and type of thermostat are free, but it may not be removed nor its position changed.

*The radiator screen may be a rigid plate fixed behind the grille.*

**d) Induction :** the carburettor(s) or fuel injector(s) pump(s) normally mounted on the recognized model and described on the recognition form may not be changed or removed.

The elements which control the quantity of fuel fed in the engine may be changed, but not those which control the quantity of air.

**e) Electrical equipment :** the tension (voltage) of the electrical equipment may not be changed.

The make and capacity (amperage) of **battery** and **generator** are free. The manufacturer may provide for one same minimum series the use either of a dynamo or of an alternator on condition that this is explicitly mentioned on the basic recognition form or on an additional "variant" form.

The original battery may be replaced—by the manufacturer or the entrant himself—by another one of larger capacity provided however that the location remains unchanged. By location of the battery is meant the coachwork compartment in which the battery is originally mounted.

**Ignition coil, condenser, distributor and regulator** are free; subject to the ignition system remaining the same as that provided by the manufacturer for the model concerned, and the replacement of the said accessories do not entail any modification of the attachment system provided by the manufacturer for the model concerned.

**Spark plugs :** make and type free.

*In case of an electric circuit under a 12 volt tension, this may be produced either by a 12 volt battery or by two 6 volt batteries connected in series on condition the batteries remain in their original location and that there is no reduction of weight as compared with the original system provided by the manufacturer.*

**f) Transmission:** for one same series of 5,000 cars the following possibilities are given on the express condition that they are those of the series-production and that they are normally sold to the purchaser and entered on the recognition form.

**Gear-box:**

- either two gear-boxes with the same number of ratios but different in their staging,
- or two gear-boxes with a different number of ratios and different in staging provided that at least 50% of the required minimum number of cars have been equipped with either one of the gear-boxes.

The fitting of an overdrive system in addition to the existing gear-box is authorized.

**Final drive:** two different ratios.

Should the manufacturer have provided a greater number of gear-box ratios and/or rear axle ratios, he must, to obtain recognition, prove that he has achieved the required minimum production of the car as many times as he has submitted two different gear-boxes and two different rear-axle ratios. An automatically controlled gear-box is not taken into consideration. The use of it and of its particular rear-axle ratio will always be authorized in addition to the set of two manually controlled gear-boxes.

The gear-box lever must be located as provided by the manufacturer and mentioned on the recognition form. Form and length are free.

*The use of an automatic gear-box is authorized but on condition this gear-box is foreseen by the manufacturer and mentioned on the recognition form. No minimum production is required.*

**g) Shock absorbers:** the make and type are free. However, no addition is allowed, and neither their original purpose nor their number, nor their system of operation may be modified. By system of operation is meant: hydraulic, friction, telescopic, or lever type. The original supports may not be changed in any way.

**h) Wheels and tyres:** wheels must be those provided by the manufacturer for the considered model. They are defined by their diameter, the width of their rim and the track they determine. Wheels which differ by their shape or dimensions may be recognized subject to the following conditions:

- that there are enough cars equipped with such wheels to justify recognition.
- that they are mounted in compliance with the specifications of paragraph "mudguards" of Art. 253.

In any case, the four wheels of a car must always belong to one and the same recognized set of wheels.

Tyres are free (make and type) on condition they are tyres provided by their manufacturer to be fitted on the wheels without any intermediary device. All special or additional non-skid devices for snow or ice may also be fitted.

**i) Brakes:** must be those provided by the manufacturer. The replacement of worn linings is authorized and their system of attachment is free, provided the dimensions of inner friction surfaces remain unchanged. Servo-assistance is only permitted when duly recognized as fitted on a number of identical cars equal at least to that required for recognition.

It is permissible to fit a dual braking system on condition that it be of the same make as that of the hydraulic master cylinder or provided by the manufacturer of the vehicle.

*The material of the brake linings is free provided the dimensions of friction surface of the new linings are the same.*

*The same applies to the clutch linings.*

**j) Supplementary accessories not included in the recognition:** are authorized without restriction provided they have no influence whatsoever on the behaviour of the car, such as those concerning the aesthetics or the inside comfort (lighting, heating, radio, etc.) or those enabling an easier or safer driving of the car (speed-pilot, windscreen washer, etc.) provided they do not affect, even indirectly the mechanical performance of the engine, the steering, the transmission, the road holding and the braking.

All controls and their functions must remain those provided by the manufacturer, but it is permissible to arrange them in such a way as to make them accessible and easier to use, i.e. lengthening of the handbrake-lever, fitting of additional pads to the brake-pedal, etc. The position of the steering-wheel may be indifferently on the left or on the right, provided this only results in a simple transposition of the steering-system linkages as provided and supplied by the manufacturer and without any other mechanical alteration (manifolds, etc.).

*The following is authorized :*

- 1) *The windshield may be replaced by a windshield of same material but with a heater-defroster device incorporated.*
- 2) *The original heater may be replaced by another one provided by the manufacturer and mentioned in his catalogue as available on request.*
- 3) *An electric water thermometer may be replaced by one of capillary type and a standard manometer by another one of high precision type.*
- 4) *The hooter may be changed or an extra one may be added, at the disposal of the passenger if wished.*
- 5) *The mechanism of the handbrake lever may be adapted for obtaining an instantaneous unbolting (fly-off handbrake). All electric switches may be freely changed, inasmuch as is concerned their purpose, their location and—in case of the adding of extra accessories—their number.*
- 6) *Extra relays and fuses may be added to the electric circuit, battery wires may be lengthened, pipes of the braking circuit may be protected by an armoured casing (metallic or other). The original accelerator cable may be replaced by another one, whether supplied or not by the manufacturer.*
- 7) *The original speedometer may be replaced by another one provided it fits exactly in the housing of the original one.*
- 8) *Seat brackets may be altered and any kind of seat-covers may be added, even those which constitute a bucket-seat.*
- 9) *Jacking points may be strengthened, their location may be changed or extra ones may be added.*
- 10) *Head-light covers may be fitted provided they do not influence the streamlining of the car.*
- 11) *Complete freedom is left with regard to the location and appearance of registration number plates, in consideration of the great differences between legal requirements from one country to another.*
- 12) *Safety fasteners (such as straps) may be fixed to the lids of the engine compartment and the luggage boot. The latter may be adapted for better accommodation of the equipment carried (straps for fixing a tool-box, protection of a supplementary fuel-tank, of an additional spare-wheel etc). The attachment system of the standard spare-wheel may be altered provided its original location is not changed.*
- 13) *Extra compartments may be added to the glove-box and extra lateral pockets to the doors.*
- 14) *Plates of insulating material may be added in all places where they may be necessary to protect those carried aboard the car from a risk of fire.*
- 15) *An oil-catch or a water-tank may be fitted.*
- 16) *The radiator filler cap may be locked by any means.*

**k) Coachwork:** none of the normal elements of the coachwork (dashboard, all inside quiltings whatever their location), and none of the accessories normally mounted by the manufacturer on the lowest priced model may be removed or replaced.

However, the modifications deriving from the fitting of the supplementary accessories authorized in the preceding paragraph, such as those necessitated by the addition of a windscreen washer (drilling of a hole into the bonnet) or of a rev. counter (housing in the dashboard), will be allowed.

The same minimum series may comprehend various materials for seats, upholstery and inside quilting (cloth, leather, plastics, etc.) and two different types of front seats (bench type or separate seats). These variants must be stated on the recognition form and in particular the different weights resulting from the mounting of different seats must be specified.

Transparent parts must, in case of damages, be replaced by others made of a material identical to the original one listed on the recognition form. They shall be completely interchangeable with those originally fitted. They must be mounted on the original supports and their original opening system (if any) must be maintained.

*Nuts and bolts may be freely exchanged and locked by pins or wires.*

*Bumper overrides may be removed.*

*When the regulations of an event allow the fitting of an undershield, the fuel and brake system pipes may be protected by all means.*

*On the contrary, the following modifications are prohibited:*

- 1) to change the rake of the steering column,*
- 2) to remove wheel-spats which are part of the coachwork,*
- 3) to add an extra bolting system of the doors,*
- 4) to add extra parking lights,*
- 5) to change the location of the opening handle of the bonnet,*
- 6) to replace the grille bolts by others of "quick-release" type.*

**l) Bumpers, embellishers, streamlining:** bumpers are compulsory on all cars for which the manufacturer has normally provided them. For speed-events on circuit and for hill-climbs, the supplementary regulations may authorize the bumpers of a car to be removed. Failing such an authorization the bumpers must remain. For rallies, any car, normally delivered with bumpers and the recognition form of which shows such an equipment, must retain them.

Wheel embellishers may be removed. The addition of any protective device underneath the car is forbidden unless such a device is mentioned on the recognition form of the model in question or is authorized or made compulsory by the supplementary regulations of the event.

## TITLE IV

### TOURING CARS

**Art. 258.—Definition:** cars of limited series-production which may be submitted to certain modifications aimed at making them better suited to competition. The list of the modifications and additions explicitly authorized is given hereafter under Art. 260.

Moreover in this group may be classed cars of group 1 which have been the subject of modifications and/or additions exceeding the limits of group 1. These cars will then enjoy the same freedom as provided for group 2.

**Art. 259.—Minimum production and number of seats:** touring cars shall have been manufactured in a quantity of at least 1,000 units and be equipped with at least 4 seats; however if their cylinder-capacity is equal or inferior to 700 cc, they may be delivered as two-seaters.

**Art. 260.—Modifications and additions authorized:** all those already authorized in group 1, plus the following ones:

**a) Lighting devices:** the mounting of additional headlights is authorized provided that a total of 6 headlights is not exceeded (parking lights not included). Extra headlights may, if necessary, be fitted into the front part of the coachwork or into the radiator grille, but such openings as needed in this case must be completely filled by the additional headlights. Shall be considered as a headlight any lighting-device throwing a beam towards the front (dipped-beam, long range lamp, anti-fog lamp).

**b) Electrical equipment:** the replacement of a dynamo by an alternator is authorized, provided the attachment system and the driving method remain unchanged. The fitting of a transistorized ignition is authorized provided there is no change of any mechanical part of the engine.

*The location of the ignition coil may be changed if necessitated by the replacement of a dynamo by an alternator.*

*The tension regulator and the fuse box may change place inside of the compartment in which they are originally located.*

**c) Reboring:** maximum tolerance: 1.2 mm, but the resulting increase in cylinder-capacity may not be such as to make the car pass into a higher cylinder-capacity class. This reboring tolerance is valid for any type of engine (with or without sleeves).

**d) Stabilizer:** the fitting of a stabilizer is authorized.

**e) Fan:** complete freedom regarding the number and the dimensions of the blades (or their complete removal) as well as the possibility of temporarily stopping their action by a clutch. The location and the driving method of the fan must remain those provided by the manufacturer and mentioned on the recognition form of the model concerned.

**f) Air-filter:** may be changed or removed.

Dynamic air intakes may be fitted on the carburettor(s) provided it entails no coachwork modification (boring of holes, for instance).

**g) Fuel-pump:** a mechanically controlled pump may be replaced by an electrically controlled one, the location of which may be different.

The type of pump is free and the fitting of a pump even of larger capacity is authorized.

The fitting of an additional pump is also authorized provided it is not connected to the fuel pipe.

**h) Oil filter and cooler:** an oil filter and/or oil cooler may be added when the model provided by the manufacturer has none, or an existing one may be altered.

**i) Carburettor(s):** the carburettor(s) provided by the manufacturer may be replaced by another (others) of a different size, provided:

— the number be the same as that provided by the manufacturer,

— they can be mounted on the inlet manifold of the engine without using any intermediary device and by using the original attachment parts.

*It is specified that the make of the carburettor replacing the original one is free; even a one-off sample is acceptable. Nevertheless, it must always be completely interchangeable with the original one without adaptation works on the inlet manifold and on the attachment parts being necessary.*

*This principle of interchangeability is also applicable to Art. 257 g) and 260 j).*

**j) Springs:** (valves, clutch, suspension, etc.) may be replaced by others of unrestricted origin, but with no modification of the number provided by the manufacturer and on condition they can be fitted without alteration of the original supports.

**k) Transmission:** may be used all gear-boxes, manual or automatic, and all final drive ratios provided and delivered by the manufacturer for the model concerned, which have been granted recognition and are entered on the recognition form. The replacement of a manually controlled clutch by an automatic one is authorized, whatever its operating system may be.

**l) Differential:** it may include a device to limit its normal functioning (limited slip control). This device must be entered on the recognition form or on an additional form (variant). The use of a device which completely blocks the functioning of the differential may not be authorized unless it has been fitted on the same minimum number of cars as necessary for recognition of the basic model.

**m) Pistons and camshaft(s):** all modifications of pistons are permitted. They may be lightened, their shape may be altered and they may even be replaced by others supplied or not by the manufacturer.

The camshaft(s) may also be altered or replaced by others supplied or not by the manufacturer.

**n) Cylinder block and head:** the increase in the compression ratio through machining of the cylinder head or block (or using a thinner gasket or removing it) is authorized.

**o) Muffler:** the make and type are free, on condition that the original exhaust manifold—and particularly its outlet port—remains entirely identical to the original part. The silencing effectiveness shall not be diminished. It shall, in any case, remain within the legal limits of the country where the event is run.

By exhaust manifold is meant the part collecting together the gases from the cylinder-head and extending to the entrance port of the first single pipe.

**p) Finishing off:** all perfecting operations by finishing or machining the original mechanical parts (to the exception of any coachwork element) but not their replacement, except with regard to springs, pistons and camshaft(s) as specified above under paragraphs j and m are authorized. In other words, provided it is always possible to ascertain unquestionably the origin of the series-production part, it may be rectified, balanced, lightened, reduced or modified with regard to the shape through tooling, to the exclusion of any addition of material or any mechanical extension or of any process involving a change of the characteristics of the molecular structure or of the surface of the metal.

*By mechanical parts are meant all those belonging to the systems ensuring propulsion, steering, suspension and braking, and all accessories which are required for the normal functioning of the said parts.*

**q) Wheels and rims:** must retain the dimensions provided by the manufacturer for his series-production model and be mentioned on the recognition form.

One basic series may include wheels of different types (solid or perforated disc wheels, spoke-wheels, etc.) and of different dimensions. But even when the recognition form mentions such difference, all four wheels must have the same dimensions.

**r) Brakes:** the fitting of a dual pump or any type of device providing both a simultaneous action on the four wheels and divided action on two wheels is authorized.

The make and attachment system of linings are free, but no other change is authorized. In particular, the dimensions of inner friction surfaces must remain unchanged.

The mounting of a braking servo-assistance system is authorized.

*Dirt shields of disc brakes may be altered but not removed.*

**s) Coachwork elements:** the steering-wheel and the front seats may be replaced, provided seats of at least the same weight as the original ones be substituted to them.

*In case of the original seats being changed the two new ones must weigh at least the weight as entered on the recognition form for the original ones, but it is not mandatory that they both weigh the same weight.*

**t) Cables and pipes:** it is allowed to entirely modify the arrangement, location and materials of all cables and pipes providing for the passage of fluid elements (air, water, fuel, electric currents, etc.).

*These words apply to the suspension system.*

*The material and location of all cables and pipes may be changed.*

**u) Fuel tanks and radiators:** additional fuel tanks and/or fuel tanks and radiators of larger capacity are authorized, provided:

1) they are provided and supplied by the manufacturer for the model concerned and mentioned on the recognition form or an additional form.

2) the fuel tanks must not:

— be a makeshift installation;

— be fitted inside the passenger's compartment, nor reduce capacity of the luggage-boot beyond the minimum specified in Art. 253, nor encroach upon the space provided for the spare-wheel;

— have a larger filling port than that of the main tank.

However for speed-events on closed circuits, the supplementary regulations may leave the dimensions of filling ports (main and auxiliary tanks) free or authorize larger ones than those provided by the manufacturer.

## TITLE V

### GRAND TOURING CARS

**Art. 261.—Definition:** cars manufactured on a small series-production scale and designed for the drivers who seek the best possible performances and/or the greatest comfort without a special concern about the cost.

**Art. 262.—Minimum production and number of seats:** grand touring cars must have been manufactured in a quantity of at least 500 units identical in all respects (unless authorizations, listed hereafter under Art. 263 specify otherwise) and be equipped with at least two seats.

**Art. 263.—Modifications and/or additions authorized:** exactly the same as those authorized for group 2 (touring cars) (see Art. 260).

## TITLE VI

### SPORTS CARS

**Art. 264.—Definition:** high performance cars which must nevertheless include all equipments normally provided and legally required for vehicles using public roads.

**Art. 265.—Minimum production and number of seats:** sports cars must have been manufactured in a quantity of at least 25 units and be equipped with at least 2 seats (as defined above under Art. 253).

**Art. 266.—Conditions required for recognition:** the 25 cars shall be identical as regards the following points:

**a) Coachwork:** general line, materials of construction, shape of wings and bonnet, number of doors. Small modifications will be allowed when made

necessary by the different uses of the car (circuit or road events), or by the mounting of supplementary equipments authorized by the present regulations.

**b) Chassis:** wheelbase and track.

*It is understood that the 25 identical cars needed for recognition in group 4 must all have the same track measurements with a set of wheels of specific size. However, during the scrutineering for an event, one must take into account the changes in track which could result from the fitting of different wheels or the modification of the suspension and/or brakes such as authorized for this group of cars.*

*The number of headlamps fitted on a car of Group 4, 5 or 6 is free.*

**c) Engine:** cylinder-head, cylinder block, number of cylinders, bore, stroke, number and location of crankshaft bearings, type of bearings and of all rotating parts; number, location and driving system of camshafts.

Number of valves and valve-operating system.

Number and location of the inlet and exhaust ports. (Free: ignition including the number of spark plugs, induction and exhaust: carburettor, filters, manifolds).

Reboring of the engine is allowed up to the limits of the cylinder-capacity class to which the model belongs.

**d) Transmission:** only one series of gears authorized, plus an automatic gearbox. Complete freedom for all gearbox and final drive ratios.

**e) Suspension:** its operating principle and function of its components.

*Four systems of independent suspension must be distinguished:*

a) *McPherson's system;*

b) *independent system by wishbones (two superposed open triangles or one closed and one open superposed triangles);*

c) *independent suspension by one trailing arm for each wheel, the main characteristic being driving axles of variable length and two universal joints for each axle (example: rear suspension of the BMW 1600).*

d) *independent suspension by swing axles, the wheels being fixed on the driving axle, i.e. rear suspension of the Renault Dauphine.*

**f) Braking systems:** the braking system (drums or discs, or drum and disc brakes) must be identical on all cars of the minimum series required for recognition. The braking system must be laid out in such a way that the brake pedal normally controls the four wheels. In case of a leak at any point of the piping or any failure in the braking transmission the brake pedal should continue to operate on at least two wheels.

*As far as the compulsory dual braking circuit for Sports Cars of Group 4 (cf Appendix J, Art. 226 f) is concerned, the following precision is given: for cars of a model originally recognized in the old GT category on the basis of a yearly production of 100 units and reclassified in the sports cars group, the fitting of such a dual braking system is not mandatory unless the supplementary regulations of the event explicitly require so.*

**g) minimum weight:** the weight of the sports cars shall be at least the one stated by their manufacturer on the recognition form of the model concerned, no reduction being allowed. This weight shall be at least equal to the minimum limits mentioned hereafter:

engine cylinder-capacity inferior or equal to	500 cc:	450 kgs
engine cylinder-capacity from	500 to	600 cc: 460 kgs
" " " "	600 to	700 cc: 470 kgs
" " " "	700 to	850 cc: 480 kgs
" " " "	850 to	1,000 cc: 500 kgs
" " " "	1,000 to	1,150 cc: 510 kgs
" " " "	1,150 to	1,300 cc: 525 kgs
" " " "	1,300 to	1,600 cc: 550 kgs





The material of the side and rear windows may be changed from glass to plastic of not less than 5 mm or 3/16th of an inch in thickness. The windscreen must be made of a safety-glass. Bumpers may be removed (though any sharp edges of bodywork left exposed must be covered). No other change in coachwork material is permitted.

Inside the car (passenger compartment) all the trim and mechanism such as window winders, etc must remain unchanged except that the carpets and floor padding can be dispensed with. A roll-over cage, if fitted, may penetrate trim or rear-seats but must nevertheless be in entire conformity with Article 253—Safety devices—of Appendix J.

Instrument panels, steering wheels, seats, etc, may of course be modified as permitted in Groups 1 and 2 of Appendix J. Those parts of the body, which are not in sight, such as wheel arches, the inside of the engine compartment and the inside of the luggage compartment may be modified. This may not result however in the removal of parts, nor lead to the deforming of the coachwork externally or internally.

On the mechanical side, apart from the original cylinder-block, clutch-housing, gearbox casing and axle banjo, which must be retained, everything is free. Moreover the above mentioned parts can be modified to attach other units to them.

So long as the camshaft remains in its original position, the cylinder-head can be changed including the porting (arrangement and number). By position is meant in the cylinder-block or in the cylinder-head.

The number of valves per cylinder may not be changed.

The exhaust system including the manifold is free. On the other hand cars of Group 5 competing in open road events must comply in every respect with the Convention on International road traffic. The number and type of bearings (plain, ball, roller) must remain as original.

The bore and the stroke may be altered so long as the engine remains in its original cylinder-capacity class such as delimited in Appendix J under Article 252.

However an engine can be moved into another class by fitting a supercharger, for then the actual cylinder-capacity will have to be multiplied by a factor of 1.4 to give the car's cylinder-capacity class.

A turbo-charger will also be regarded as a supercharger.

The position and the inclination of the engine are free within the limits of the original engine compartment.

The radiator, including its capacity is free. Its location may be changed provided the interior (passenger compartment) and exterior appearance of the coachwork remains unchanged.

The fuel tank capacity is free within the limits specified by Appendix J under Art. 253. When replacing the original tank it is recommended to fit a safety-type fuel tank.

The location and the dimensions of the filling port and cap may be changed provided the new arrangement is aesthetically acceptable, does not break the line of the coachwork and ensures that any spilled fuel does not enter any internal compartment of the car.

If a car is fitted with a solid axle, this must be retained but leaf springs may be replaced by locating arms and another type of spring. If independent suspension is fitted, the system must not be changed, but the springing medium can be.

Shock-absorbers are free, including their number and mounting.

Transmission ratios are free including the number of gear ratios. It is also permitted to fit a device limiting the normal functioning of the differential, provided it can be fitted in the original differential casing.

Wheels and their method of attachment are free so long as their diameter is one of these recognized for the car.

The track is free but the wings shall cover at least one-third of the circumference of each wheel fitted with its tyre (Appendix J, Art. 253).

Wing-extensions may only be used when duly recognized for the car model concerned. The fitting of wider wheels is subject to the car remaining in compliance

with the specifications concerning maximum turning radius (Appendix J, Art. 253),  
Moreover the ground-clearance of the car may not be inferior to 10 cms (Art. 253, Appendix J).

## TITLE VIII

### PROTOTYPE SPORTS CARS

**Art. 281.—Definition:** experimental competition cars especially manufactured for speed or endurance races on closed circuits. Their use on open roads may be foreseen and in that case, the cars must include all equipments normally provided and legally required for vehicles using public roads.

**Art. 282.—Specifications:** these cars shall meet all general prescriptions concerning cars of categories A and B (see Art. 253) except for the following points:

- a) the protected height of at least 80 cm is optional (Art. 253 b 2nd case),
- b) the windscreen is optional (Art. 253 c), but if there is one, its dimensions are free,
- c) the hood is optional (Art. 253 e),
- d) luggage space is optional (Art. 253 h),
- e) the spare wheel is optional (Art. 253 k).

Furthermore, prototype sports cars must be fitted with a double braking system such as specified under Art. 266 f.

As regards open cars, the following specifications must be complied with:

- if the windscreen height is reduced to such an extent that the driver looks over the top of it instead of through it, it may be considered as a mere wind-deflector. In that case, it may be of transparent plastic material and wipers are optional.
- unimpeded rear view must be ensured (for instance, by a rear-viewing mirror on either side of the vehicle).

## TITLE IX

### NON DEFINED CARS

**Art. 283.—Special ruling for rallies:** promoters may allow participation in an event of cars of any type and which do not correspond to any of the above categories or groups, such as for instance military cars, buses, lorries, etc.

But in this case these non-defined vehicles shall have to be classed separately and may under no condition be mingled with other cars in the general classification of the event.

## TITLE X

### TWO-SEATER RACING CARS

**Art. 284.—Definition:** two-seater competition vehicles built exclusively for speed races on closed circuits.

**Art. 285.—Classification of cars shall be according to engine displacement as follows:**

- |             |                      |                   |
|-------------|----------------------|-------------------|
| 1st series: | inferior or equal to | 850 cc            |
| 2nd series: | from                 | 850 to 1,150 cc   |
| 3rd series: | from                 | 1,150 to 1,600 cc |
| 4th series: | from                 | 1,600 to 2,000 cc |
| 5th series: | from                 | 2,000 to 3,000 cc |
| 6th series: | from                 | 3,000 to 5,000 cc |
| 7th series: |                      | over 5,000 cc     |