

2014 FIA FORMULA E SPORTING REGULATIONS

Art	CONTENTS	Page(s)	Art	CONTENTS	Page(s)
1	REGULATIONS	2	28	SPARE CARS, MOTORS, BATTERIES, GEARBOX	16
2	GENERAL UNDERTAKING	2	29	ELECTRICITY, CHARGING	16
3	GENERAL CONDITIONS	2	30	GENERAL SAFETY	17-18
4	LICENCES	3	31	PRACTICE SESSIONS	18
5	CHAMPIONSHIP EVENTS	3	32	NON-QUALIFYING PRACTICE SESSIONS	19
6	FORMULA E CHAMPIONSHIP	3-4	33	QUALIFYING PRACTICE SESSIONS	19
7	DEAD HEAT	4	34	POST QUALIFYING PARC FERME	19
8	PROMOTER	4	35	THE GRID	19-20
9	ORGANISATION OF EVENTS	4	36	STARTING PROCEDURE	20-22
10	INSURANCE	4-5	37	THE RACE	22
11	FIA DELEGATES	5	38	SAFETY CAR	22-24
12	OFFICIALS	5-6	39	SUSPENDING A RACE	24-25
13	COMPETITORS APPLICATIONS	6-7	40	RESUMING A RACE	25-26
14	PASSES	7	41	FINISH	26
15	INSTRUCTIONS, COMMUNICATIONS TO COMPETITORS	7	42	PARC FERME	26
16	INCIDENTS	7-8	43	CLASSIFICATION	26
17	PROTESTS AND APPEALS	9	44	PODIUM CEREMONY	27
18	SANCTIONS	9	45	PRESS CONFERENCES AND PROMOTION AFTER RACE	27
19	CHANGES OF DRIVER	9			
20	DRIVING	9-10			
21	CAR LIVERY	10	APPENDIX 1:	INFORMATION REQUIRED UNDER ARTICLE 9.2	28-31
22	TRACK TESTING	10-11	APPENDIX 2:	PODIUM CEREMONY	32-33
23	PIT ENTRY, PIT LANE AND PIT EXIT	11-12	APPENDIX 3:	ORGANISATION RULES	34-39
24	SCRUTINEERING AND ADMINISTRATIVE CHECKS	12-13	APPENDIX 4:	TEAM SUPPORT PACKAGE	40
25	TYRES AND TYRE LIMITATION DURING THE EVENT	13-14			
26	WEIGHING	14-15			
27	GENERAL CAR REQUIREMENTS	15-16			

FOREWORD

The FIA will organise the FIA Formula E Championship (the Championship) which is the property of the FIA and comprises two titles of Formula E Champion, one for drivers and one for teams. It consists of the Formula E races which are included in the Formula E calendar. All the participating parties (FIA, ASNs, organisers, competitors and circuits) undertake to apply as well as observe the rules governing the Championship.

1) REGULATIONS

- 1.1 The final text of these Sporting Regulations shall be the English version, which will be used should any dispute arise as to their interpretation. Headings in this document are for ease of reference only and do not form part of these Sporting Regulations. Changes to these Sporting Regulations must be made in accordance with Chapter XV of the International Sporting Code hereinafter "the Code".
- 1.2 These Sporting Regulations come into force from the moment of their publication on the FIA website (www.fia.com), and replace all previous Sporting Regulations.

2) GENERAL UNDERTAKING

- 2.1 All drivers, competitors and officials participating in the Championship undertake, on behalf of themselves, their employees, agents and suppliers, to observe all the provisions as supplemented or amended of the Code, the FIA General Prescriptions, the Technical Regulations and the present Sporting Regulations, together referred to as "the Regulations".
- 2.2 The Championship and each of its Events are governed by the FIA in accordance with the present Regulations. Event means any event counting towards the Championship and registered on the FIA International Calendar for any year, commencing at the scheduled time for scrutineering and sporting checks and including all practice sessions and the race itself and ending at either the time for the lodging of a protest under the terms of the Code or the time when a technical or sporting certification has been carried out under the terms of the Code, whichever is later.
- 2.3 Any special national regulations must be submitted to the FIA with the original application for inclusion of an event on the international calendar. Only with the approval of the FIA can such special regulations come into force for an event. The FIA will ensure that all applicant competitors are informed of such special regulations before entries close.

3) GENERAL CONDITIONS

- 3.1 It is the competitor's obligation to ensure that all persons concerned by his entry observe all the requirements of the Code, the FIA General Prescriptions, the Technical Regulations, the Sporting Regulations and the Organisation Rules.

If a competitor is unable to be present in person at the Event, he must nominate his representative in writing.

Throughout the entire duration of the Event, a person having charge of an entered car during any part of an Event is responsible jointly and severally with the competitor for ensuring that the requirements are observed.

- 3.2 Competitors must ensure that their cars comply with the conditions of eligibility and safety throughout the Event.
- 3.3 The presentation of a car for scrutineering will be deemed an implicit statement of conformity.
- 3.4 All persons concerned in any way with an entered car or present in any other capacity whatsoever in the paddock, pits, pit lane, or track must wear an appropriate pass at all times.

4) LICENCES

- 4.1 Competitors and officials participating in the Championship must hold current and valid E Licences issued by the FIA.
- 4.2 Drivers participating in the Championship must hold current and valid E Licences and, as a minimum requirement, Grade B FIA International driver's licence and, where applicable, valid licences and/or authorisations issued by their ASN.

A driver must also be in possession of a current medical certificate of aptitude, either included on competition licence or on attached document.

5) CHAMPIONSHIP EVENTS

- 5.1 Events are reserved for Formula E cars as defined in the current FIA Technical Regulations.
- 5.2 Each Event will have the status of an international restricted competition.
- 5.3 The Event shall include all practice sessions and races.
- 5.4 The maximum number of Events in the Championship is 12, and the minimum is 6.
- 5.5 The final list of Events will be published by the FIA before 1st January each year.
- 5.6 An Event which is cancelled with less than three months written notice to the FIA will not be considered for inclusion in the following year's Championship unless the FIA judges the cancellation to have been due to force majeure.
- 5.7 An Event may be cancelled if fewer than 12 drivers are available for it.

6) FORMULA E CHAMPIONSHIP

- 6.1 The Formula E Championship driver's title will be awarded to the driver who has scored the highest number of points, taking into account the results of all the competitions in the Championship minus one. A blank result due to an exclusion may not be discounted.
- 6.2 The Formula E Championship team title will be awarded to the competitor which has scored the highest number of points, taking into account the cumulated results from the two drivers of the team.

- 6.3 Points for both titles will be awarded at each Event according to the following scale:

1st	:	25 points
2nd	:	18 points
3rd	:	15 points
4th	:	12 points
5th	:	10 points
6th	:	8 points
7th	:	6 points
8th	:	4 points
9th	:	2 points
10th	:	1 point

Pole position: 3 points

Fastest lap: 2 points

- 6.4 If a race is suspended under Article 39, and cannot be resumed, no points will be awarded if the leader has completed less than two laps, half points will be awarded if the leader has completed more than two laps but less than 75% of the original race distance and full points will be awarded if the leader has completed 75% or more of the original race distance.

Full points will however be awarded if the maximum race time is reached before 75% of the original race distance was completed by the leader.

- 6.5 If required by the FIA to do so the drivers finishing first, second and third, and the Team Principal in the Championship must be present at the annual FIA Prize-Giving ceremony.

7) DEAD HEAT

- 7.1 Prizes awarded for all the positions of competitors who tie will be added together and shared equally.
- 7.2 If two or more drivers or teams finish the season with the same number of points, the higher place in the Championship shall be awarded to:
- a) The holder of the greatest number of first places.
 - b) If the number of first places is the same, the holder of the greatest number of second places.
 - c) If the number of second places is the same, the holder of the greatest number of third places, and so on until a winner emerges.
 - d) If this procedure fails to produce a result, the FIA will nominate the winner according to such criteria as it thinks fit.

8) PROMOTER

- 8.1 An application to promote an Event must be made to the ASN of the country in which the Event is to take place, which will apply to the FIA. It must be accompanied by written evidence that the Promoter has made arrangements to secure the participation of competitors, which arrangements are conditional only upon the FIA entering the Event on the Championship calendar.

9) ORGANISATION OF EVENTS

Each organiser, via its ASN, shall supply the information set out in Appendix 1, part A hereto, to the FIA, in English at least, no later than 60 days before the Competition, together with the detailed timetable and the Organisation Agreement described hereinafter (Part C & D of Appendix 1) and the Medical Questionnaire in accordance with Appendix H of the International Sporting Code, at least two months before the Competition. Part B of Appendix 1 will be completed by the FIA and returned to the ASN concerned no later than 30 days before the Competition. Each Competition will be organised in accordance with the Organisation Agreement entered into between the organiser of the Competition, the ASN of the organising country and the FIA.

A visa is issued by the FIA for each of the Competitions, provided that all the documents required by the present regulations have been duly sent to the FIA by the aforementioned deadlines and that they are in conformity with the regulations applicable to the Championship. Each Competition must be organised in strict compliance with these documents.

If the ENECC Commission considers it necessary, observation of new circuits, or of circuits entered on the calendar of the following year, may be carried out by an Observer designated by the Commission, at a national or international Competition held on that same circuit within the time limit stipulated by the Commission. After this observation, the Observer will draft his report on the Competition. This report is then submitted to the ENECC Commission, which decides whether the Competition is of a sufficiently high standard for an FIA Championship Competition to be held at that circuit.

10) INSURANCE

- 10.1 The organiser of an Event must ensure that all competitors, their personnel and drivers are covered by third party insurance.
- 10.2 Thirty days before the Event, the organiser, via its ASN must send the FIA, at least in English, details of the risks covered by the insurance, which must comply with the national laws in force. This insurance certificate, written in the language of the country as well as in English, shall be made available to the competitors.
- 10.3 Third party insurance arranged by the organiser shall be in addition and without prejudice to any personal insurance policy held by a competitor or by any other natural person or legal entity taking part in the Event.
- 10.4 Drivers taking part in the Event are not third parties with respect to one another.

11) FIA DELEGATES

- 11.1 For each Event the FIA shall nominate the following delegates:
 - a) A technical delegate
 - b) Technical delegate assistants
 - c) A media delegate
 - d) A medical delegate
 - e) A safety car driver
- 11.2 The role of FIA delegates is to help the officials of the Event in their duties, to see within their fields of competence that all the Regulations governing the Championship are respected, to make any comments they deem necessary and to draw up any necessary reports concerning the Event.
- 11.3 The technical delegate nominated by the FIA will be responsible for scrutineering and will have full authority over the national Scrutineers.

12) OFFICIALS

- 12.1 The following officials shall be nominated by the FIA:
 - a) A Race Director.
 - b) A Race Director Assistant.
 - c) A permanent Chairman of the Panel of Stewards.
 - d) A second International Steward of a nationality different to that of the organiser.

In accordance with Article 134 of the Code, the stewards of the meeting will officiate as a body under the authority of their Chairman.
- 12.2 The following officials will be nominated by the ASN exclusively for the FIA Event(s) and their names sent to the FIA at the same time as Appendix 1, Part A, is sent to the FIA:
 - a) A steward.
 - b) A clerk of the course.
 - c) A secretary of the Event.
 - d) A chief national scrutineer.
 - e) A chief national medical officer.
- 12.3 The clerk of the course shall work in permanent consultation with the race director. The race director shall have overriding authority in the following matters and the clerk of the course may give orders in respect of them only with his express agreement:

- a) The control of practice and the race, adherence to the timetable and, if he deems it necessary, the formulation of any proposal to the stewards to modify the timetable in accordance with the Code or Sporting Regulations.
 - b) The stopping of any car in accordance with the Code and with the Sporting Regulations.
 - c) The interruption of practice.
 - d) The starting procedure.
 - e) The use of the safety car.
 - f) The suspending and resuming of the race.
- 12.4** The race director, the clerk of the course, the technical delegate and the national steward(s) must be present at the circuit at the latest from the beginning of the Event as defined by the Code, and the FIA stewards before the end of initial scrutineering. The FIA stewards must not leave before the end of final scrutineering and the appeal procedure in accordance with Article 13.4.1 of the Code.
- 12.5** The race director must be in permanent radio contact with the clerk of the course, the technical delegate and the chairman of the stewards at all times when cars are permitted to run on the track. Additionally, the clerk of the course must be at race control and in radio contact with all the marshals' posts. The Promoter is responsible for the proper functioning of the radio equipment.

13) COMPETITORS APPLICATIONS

- 13.1** Applications to compete in the Championship must be submitted to the Promoter until 22 December 2013.

Application dossiers must be returned to the Promoter, in the original form by post, completed and signed, to the following address, postmarked no later than 22 December 2013.

FORMULA E OPERATIONS

8th Floor
 25 Berkeley Square
 London W1J 6HN
 United Kingdom

- 13.2** Applications shall include:

- a) A proposing letter by the FE Promoter.
- b) Confirmation that the applicant has read and understood the Regulations and agrees, on its own behalf and on behalf of everyone associated with its participation in the Championship, to observe them.
- c) The name of the team.
- d) The make of the competing car.
- e) The make of the motor.
- f) An undertaking by the applicant to participate in every Event with the number of cars and drivers entered.
- g) Confirmation from the team that it has informed all its drivers of the obligation to use an FIA-approved head restraint. Under no circumstances may a helmet be modified after delivery by the manufacturer.
- h) Information about the size of the company, its financial position and its ability to meet the prescribed obligations.

- 13.3** No more than 10 teams will be admitted to the Championship.

- 13.4** The final list of selected competitors in the Championship and two reserves is validated by the FIA FE Committee, composed of the ENECC President, the FIA Technical Director, the FIA Marketing Director and the FIA Sporting Director.

Therefore, all applications will be proposed by the Promoter to the FIA and each dossier will be detailed with information listed in Article 13.2. These dossiers will be studied by the FIA and accepted or rejected at its absolute discretion.

The FIA will publish the list of competitors accepted on or before 1 May 2014, having first notified unsuccessful applicants as set out in Article 13.1. Out-of-time applications will be considered separately.

Selected competitors will from that date be invited to register in the Championship. Competitors will not be considered as definitively admitted to the Championship until payment of the full entry fee (specified under Article 13.5) has been received by the FIA, by 27 May 2014 at the latest.

The FIA reserves the right to reject an entry if the above fees are not paid on or before the due date.

Each driver accepted for the Championship will be allocated a specific start number, which will be valid for the entire Championship. Each team must let FEH know which numbers they would like by 30 June each year. FEH will then send a summary table to the FIA. The FIA will confirm the list of numbers allocated to each competitor by 30 July of each year at the latest.

The number 1 will automatically be attributed to the team that won the Championship the previous year.

In the case of the rejection or the defect of one of the teams selected in the main list, one or several substitute teams will be requested to confirm their application within 5 days.

- 13.5** The entry fee per team per season is €50,000. The entry fee is due upon entry to compete in the Championship.

- 13.6** Each team may enter two drivers in the Championship, each with two dedicated cars, and one reserve driver.

Confirmation that the intended drivers have complied with the requirements of these Sporting Regulations, the full names and record of achievements of each of the drivers, a photocopy of the driver's licence for the year concerned and a copy of the identity card or passport of each driver should be sent to the FIA by 15 July 2014.

- 13.7** If in the opinion of the FIA a competitor fails to operate his Team in a manner compatible with the standards of the Championship or in any way brings the Championship into disrepute, the FIA may exclude such competitor from the Championship forthwith.

- 13.8** The FIA may cancel the Championship if less than 6 Teams are entered for it by the closing date for entries.

- 13.9** Any driver entered in the Championship and who is unable to take part in an Event must inform the FIA in writing before the end of initial scrutineering of the Event in question.

14) PASSES

- 14.1** No pass may be issued or used other than the one issued by the Promoter with the agreement of the FIA. A pass may be used only by the person and for the purpose for which it was issued. Permanent FIA passes will be allowed.

15) INSTRUCTIONS AND COMMUNICATIONS TO COMPETITORS

- 15.1** The stewards or race director may give instructions to competitors by means of special circulars in accordance with the Code. These circulars will be distributed to all competitors, who must acknowledge receipt.

- 15.2 All classifications and results of practice and the race, as well as all decisions issued by the officials, will be posted on the official digital notice board (<http://fiaformulae.alkamelsystems.com/>).
- 15.3 Any decision or communication concerning a particular competitor should be given to him within twenty five minutes of such decision, and receipt must be acknowledged.

16) INCIDENTS

16.1 "Incident" means any occurrence or series of occurrences involving one or more drivers, or any action by any driver, which is reported to the stewards by the race director (or noted by the stewards and subsequently investigated) which:

- a) Necessitated the suspension of a race under Article 39.
- b) Constituted a breach of these Sporting Regulations or the Code.
- c) Caused a false start by one or more cars.
- d) Caused a collision.
- e) Forced a driver off the track.
- f) Illegitimately prevented a legitimate overtaking manoeuvre by a driver.
- g) Illegitimately impeded another driver during overtaking.

Unless it was completely clear that a driver was in breach of any of the above, any incidents involving more than one car will normally be investigated after the race.

- 16.2
- a) It shall be at the discretion of the stewards to decide, upon a report or a request by the race director, if a driver or drivers involved in an incident shall be penalised.
 - b) If an incident is under investigation by the stewards a message informing all teams which driver or drivers are involved will, where possible, be displayed on the timing monitors (if the facilities on the circuit so permit).

Provided that such a message is displayed within 25 minutes of the end of the race, or a message is delivered to any team concerned within this time, the driver or drivers concerned may not leave the circuit without the consent of the stewards.

16.3 The stewards may impose any one of the penalties below on any driver involved in an Incident:

- a) A drive-through penalty. The driver must enter the pit lane and re-join the race without stopping.
- b) A ten second time penalty. The driver must enter the pit lane, stop at the penalty box for at least ten seconds and then re-join the race.

If either of the two penalties above are imposed during the last two laps, or after the end of a race, Article 16.4b) below will not apply and 30 seconds will be added to the elapsed race time of the driver concerned in the case of a) above and 40 seconds in the case of b).

- c) A time penalty.
- d) A reprimand.

If any of the four penalties above are imposed they shall not be subject to appeal.

- e) A drop of any number of grid positions at the driver's next Event.
- f) Exclusion from the results.
- g) Suspension from the driver's next Event.

16.4 Should the stewards decide to impose either of the penalties under Article 16.3a) or b), the following procedure will be followed:

- a) The stewards will give written notification of the penalty which has been imposed to the competitor concerned and, where possible, will ensure that this information is also displayed on the timing monitors.
- b) From the time the stewards' decision is notified on the timing monitors, the relevant driver may cross the Line on the track no more than twice before entering the pit lane and, in the case of a penalty under Article 16.3b), proceeding to the penalty box, where he shall remain for the period of the time penalty.

However, unless the driver was already in the pit entry for the purpose of serving his penalty, he may not carry out the penalty after the safety car has been deployed. The number of times the driver crosses the Line behind the safety car will be added to the maximum number of times he may cross the Line on the track.

Whilst a car is stationary in the pit lane as a result of incurring a time penalty it may not be worked on. However, if the engine stops it may be started after the time penalty period has elapsed.

- c) When the time penalty period has elapsed the driver may re-join the race.
- d) Any breach or failure to comply with Articles 16.4b) or c) may result in the car being excluded.

17) PROTESTS AND APPEALS

17.1 Protests shall be made in accordance with the Code and accompanied by a fee of €2000.

17.2 Appeals may not be made against decisions concerning the following:

- a) Penalties imposed under Articles 16.3 a), b), c) or d), including those imposed during the last two laps or after the end of a race.
- b) Any drop of grid positions imposed under Article 28.4 and 16.3.
- c) Any penalty imposed under Article 31.4.
- d) Any decision taken by the stewards in relation to Article 35.4.

18) SANCTIONS

18.1 The stewards may inflict the penalties specifically set out in these Sporting Regulations in addition to or instead of any other penalties available to them under the Code.

18.2 Any driver who receives three reprimands in the same Championship season will, upon the imposition of the third, be given a ten grid place penalty at that Event. If the third reprimand is imposed following an Incident during a race, the ten grid place penalty will be applied at the driver's next Event.

The ten grid place penalty will only be imposed if at least two of the reprimands were imposed for a driving infringement.

19) CHANGES OF DRIVER

19.1 Changes may be made at any time before the start of the non-qualifying practice session provided any change proposed after 16.00 on the day of scrutineering receives the consent of the stewards. Additional changes for reasons of force majeure will be considered separately.

Any new driver may score points in the Championship.

19.2 Any driver already nominated by one team, who then wishes to drive for another team entered in the Championship, must first satisfy the FIA that this is being done with the consent of the original team. If there is no such consent the FIA will decide, at its absolute discretion, whether such a change may be made.

20) DRIVING

20.1 The driver must drive the car alone and unaided.

20.2 Drivers must use the track at all times. For the avoidance of doubt the white lines defining the track edges are considered to be part of the track but the kerbs are not.

A driver will be judged to have left the track if no part of the car remains in contact with the track.

Should a car leave the track the driver may re-join; however, this may only be done when it is safe to do so and without gaining any advantage.

A driver may not deliberately leave the track without justifiable reason.

20.3 More than one change of direction to defend a position is not permitted. Any driver moving back towards the racing line, having earlier defended his position off-line, should leave at least one car width between his own car and the edge of the track on the approach to the corner.

20.4 Any driver defending his position on a straight, and before any braking area, may use the full width of the track during his first move, provided no significant portion of the car attempting to pass is alongside his. Whilst defending in this way the driver may not leave the track without justifiable reason.

For the avoidance of doubt, if any part of the front wing of the car attempting to pass is alongside the rear wheel of the car in front this will be deemed to be a 'significant portion'.

20.5 Manoeuvres liable to hinder other drivers, such as deliberate crowding of a car beyond the edge of the track or any other abnormal change of direction, are not permitted.

20.6 As soon as a car is caught by another car which is about to lap it during the race the driver must allow the faster driver past at the first available opportunity. If the driver who has been caught does not allow the faster driver past, waved blue flags will be shown to indicate that he must allow the following driver to overtake.

20.7 The driver is not permitted to participate in any additional practice, qualifying or race within the Event.

21) CAR LIVERY

21.1 Each car must carry the race number of its driver as published by the FIA. The race number must be visible on the rear wing side plates of the car in accordance with the requirements of the Team Support Package (Appendix 4).

Race number colours and graphics will be imposed and will be different for each of the two cars available for each driver as:

- For the race numbers of each car: font Neo Sans Bold Italic, 30 cm high and stroke 25 mm.
- For the race number backgrounds of the same driver: black on white for his first car and white on black for his second car.

21.2 Every competitor must display the name of the driver and his national flag on the bodywork or on the outside of the cockpit. These must be clearly legible and, where applicable, in accordance with the requirements of the Organisation Rules.

21.3 Each car must carry the logos of the official partners of the Championship in accordance with the requirements of the Team Support Package (Appendix 4).

21.4 Both cars entered for a competitor must be presented in substantially the same livery at each Event.

22) TRACK TESTING

Testing with Formula E cars is not permitted for drivers and competitors participating in the Championship with the exception of official tests organised by the Promoter.

- 22.1** Track testing should be considered any track running time which is not part of an Event and which is undertaken by a competitor entered in the Championship using cars which conform substantially to the current Formula E Technical Regulations in addition to those of the prior or subsequent year.

The only exception is that each competitor is permitted up to 3 promotional events, carried out using tyres provided specifically by the appointed Championship supplier to a maximum distance of 50 km per event. Rig testing, wind tunnel testing, and CFD studies are strictly forbidden. Competitors agree that the FIA shall send a representative to each of these Events who shall be granted access to the cars at any time (day or night) that they are not under the control of FE.

Testing, which is compulsory for all teams, may only be carried out in accordance with Article 21.2. Any other track running time undertaken by, or on behalf of, a team entered in the Series (or which is suspected of being connected in any way whatsoever with a team entered in the Series) is prohibited.

- 22.2** Testing of Formula E cars must take place in accordance with the following:

Each season, Formula E will organise between 8 and 10 Official Team test sessions of one, two or three-day official tests. At least 6 of these test sessions will take place before the first Event of the Championship.

Testing will consist of a three-hour morning session and a three-hour afternoon session. During these sessions, cars may be divided into groups to avoid traffic.

During each of these tests:

- A maximum of 4 drivers per competitor will be allowed.
- A maximum of 4 cars per competitor will be allowed.
- No more than 2 cars per competitor will be allowed on track at the same time.
- No more than 5 sets of new all-weather tyres per day and per competitor will be allowed.

At the end of each Formula E test, all tyres must be returned to the tyre manufacturer.

- 22.3** During all testing:

- a) Red flag and chequered flag procedures must be respected;
- b) No vehicle type other than Formula E is permitted on the track;
- c) Every reasonable effort should be made to ensure that the recommendations concerning emergency services detailed in Article 16 of Appendix H to the Code are followed.

23) PIT ENTRY, PIT LANE AND PIT EXIT

- 23.1** The section of track between the first safety car line and the beginning of the pit lane will be designated the "pit entry".

- 23.2** The section of track between the end of the pit lane and the second safety car line will be designated the "pit exit".

- 23.3** The pit lane will be divided into two lanes, the lane closest to the pit wall will be designated the "fast lane" and the lane closest to the garages will be designated the "inner lane".

Other than when cars are at the end of the pit lane under Articles 36.2 and 36.8, the inner lane is the only area where any work can be carried out on a car. However, no work may be carried out in the fast lane if it is likely to hinder other cars attempting to leave the pit lane.

23.4 Unless a car is pushed from the grid at any time during the start procedure, cars may only be driven from the teams designated garage area to the end of the pit lane.

Any car(s) driven to the end of the pit lane prior to the start or re-start of a practice session, or any car(s) required to stop at the pit exit during a safety car period, must form up in a line in the fast lane and leave in the order they got there unless another car is unduly delayed.

23.5 Any driver that is required to start the race from the pit lane may not drive his car from his teams designated garage area until the ten minute signal has been given and must stop in a line in the fast lane. Under these circumstances working in the fast lane will be permitted, but any such work is restricted to:

- a) Changes made for driver comfort.
- b) Changing of wheels.

When cars are permitted to leave the pit lane they must do so in the order that was established under Article 35 unless another car is unduly delayed.

At all times drivers must follow the directions of the marshals.

23.6 Other than drying, sweeping of any tyre rubber left when cars leave their pit stop position, competitors may not attempt to enhance the grip of the surface in the pit lane unless a problem has been clearly identified and a solution agreed to by the race director.

23.7 Competitors must not paint lines on, or modify in any way, any part of the pit lane.

23.8 Other than in Article 23.5 above no equipment may be left in the fast lane and or the pit lane. A car may enter or remain in the fast lane only with the driver sitting in the car behind the steering wheel in his normal position even when the car is being pushed.

23.9 It is the responsibility of the driver to leave his car at a pit stop only when it is safe to do so, the ready-to-move mode is deactivated and the white light is off.

It is the responsibility of the driver to release his car after a pit stop only when it is safe to do so, all safety requirements have been fulfilled and his seat belt fastened, before activating the ready-to-move mode, at which time the white light must be turned on.

23.10 Cars may not enter the fast lane of the pits until the pit exit is opened at the start or re-start of each practice or qualifying session. Furthermore, no car may be moved to a position in the slow lane which is closer to the pit exit than the garage which has been assigned to the relevant Team.

23.11 All pit road garage doors must remain open during all qualifying practice sessions and the race.

23.12 Under exceptional circumstances the race director may ask for the pit entry to be closed during the race for safety reasons. At such times drivers may only enter the pit lane in order for essential and entirely evident repairs to be carried out on the car.

24) SCRUTINEERING AND ADMINISTRATIVE CHECKS

24.1 The following documents must be submitted to the clerk of the course by each team during initial scrutineering:

- a) Competitors' FIA E licences.
- b) Driver's licence (minimum Grade B) and specific FIA E licence.
- c) Medical certificate of aptitude.

24.2 Drivers with medical peculiarities (as for example allergies, bleeder, diabetic etc.) are obliged to submit written information to the chief medical officer before the first practice starts. This information must include the name and number of the race car. Participants with injuries or temporary handicaps are obliged to contact the chief medical officer immediately. The chief medical officer will decide if such a driver will be admitted to the Event.

- 24.3 During initial scrutineering, and at any time during the Event, each competitor must have available all documents required by Article 24.1 above in addition to the car's technical passport.
- 24.4 Unless a waiver is granted by the stewards, competitors who do not keep to time limits will not be allowed to take part in the Event.
- 24.5 a) Initial scrutineering of the car will take place in the FIA scrutineering bay or in the team's garages, when practical. The electronic technical passport must have been completed on the dedicated website by noon on the day before the event.
- b) In order that scrutineers have the required access, all pit lane garage doors must be left open during all qualifying practice sessions and the race.
- 24.6 Race numbers and any official advertising must be on the car for inspection during scrutineering.
- 24.7 No car may take part in the Event until it has been passed by the scrutineers.
- 24.8 The scrutineers may:
- a) Check the eligibility of a car or of a competitor at any time during the Event.
- b) Require a car to be dismantled by the competitor to make sure that the conditions of eligibility or conformity are fully satisfied.
- c) Require a competitor to pay the reasonable expenses which exercise of the powers mentioned in this Article may entail.
- d) Require a competitor to supply them with such parts or samples as they may deem necessary.
- 24.9 Any car which, after being passed by the scrutineers, is dismantled or modified in a way which might affect its safety or call into question its eligibility, or which is involved in an accident with similar consequences, must be re-presented for scrutineering approval.
- 24.10 The race director or clerk of the course or his deputies may require that any car involved in an accident be stopped and checked.
- 24.11 After each race and all qualifying practice sessions, cars will be selected and must undergo complete scrutineering.
- 24.12 Checks and scrutineering shall be carried out by duly appointed officials who shall be responsible for the operation of the parc fermé and who alone are authorised to give instructions to the competitors.
- 24.13 The stewards will publish the findings of the scrutineers each time cars are checked during the Event. These results will not include any specific figure except when a car is found to be in breach of the Technical Regulations.
- 24.14 A briefing chaired by the race director will take place on the day of initial scrutineering at a location to be advised. All drivers entered for the Event and their team managers must be present.
- 24.15 Before the end of initial scrutineering each competitor must specify which of its drivers will be driving which cars. After this point, no changes may be made to the original allocation.
- 24.16 After initial scrutineering and before the first practice session, all the cars will be in Parc Ferme regime in the team's garages from During this period, no team member is allowed in the garages. This is the curfew period.

25) TYRES AND TYRE LIMITATION DURING THE EVENT

- 25.1 Only tyres which have been provided at the Event by the FIA appointed supplier may be used throughout the Event.
- 25.2 All tyres must be used as supplied by the manufacturer. Any modification or treatment such as cutting, grooving, scrubbing in, the application of solvents or softeners, the fitting of heat retaining devices or pre-heating is therefore prohibited.

The only acceptable variation from the standard tyre specification will be that made on decision of the tyre supplier and applied to all tyres of the same specification supplied for the Event.

- 25.3 Per Event, each driver may use no more than five new rear and five new front all-weather tyres of the same specification. One front tyre and one rear tyre must come from the previous Event (except for the first race of the Championship where only new tyres will be considered). All tyres must be strictly identical.

At the end of each Event, all tyres must be returned to the tyre manufacturer.

Only tyres which have been provided at the Event by the FIA-appointed supplier and allocated to a car by the FIA technical delegate may be used throughout the Event.

On the sidewall of each tyre, appropriate identification will be applied.

No tyre allocated for one Event may be used at another.

During all practice sessions and races, only allocated tyres are allowed in the pits.

- 25.4 A competitor wishing to replace an already marked unused tyre by another identical unused one must present both tyres to the FIA technical delegate.

- 25.5 All tyres will be supplied with a defined identification (RFID and/or barcode). In case of barcodes, type 39 or 128 will be accepted, composed of 6 digits, only edited with figures starting with 3, 4, 5, 6, 7, 8 or 9 will be accepted.

- 25.6 The use of tyres without appropriate identification may result in a grid position penalty or exclusion from the race.

- 25.7 Tyres may only be inflated with air. Any form of altering the air is forbidden, e.g. de-humidification machine.

- 25.8 All tyres, when under the control of a team, must remain visible within the team's designated garage area at all times.

At his absolute discretion, the FIA technical delegate may enforce parc fermé conditions on tyres at any time. Where this is deemed necessary, details will be published by the stewards.

- 25.9 The scrutineers appointed for marking will supervise tyre changes.

- 25.10 The tyre manufacturer engineers will be allowed to control and measure tyre temperatures and pressures at any time during the Event.

- 25.11 All competitors must respect the working ranges of the tyres (minimum and maximum camber, minimum cold and hot pressure) as communicated by the tyre manufacturer before the end of initial scrutineering.

- 25.12 Each team will be provided with one set of typhoon tyres per car at the beginning of the season. These tyres will be used as transportation tyres and will be kept by the tyre supplier during an event.

In case of extreme wet conditions, typhoon tyres can be used only after a decision by the Race Director.

Once used, the typhoon tyres will be replaced with new ones by the tyre supplier at the next event for all the teams.

26) WEIGHING

- 26.1 a) During each qualifying session and race, cars will be weighed as follows:
- i) At the scrutineering bay, the organiser will provide a flat horizontal surface measuring 10 m x 4 m. This area will be used for the weighing procedure. After qualifying practice, the weight of the cars may also be checked in parc fermé.
 - ii) At the end of each qualifying session, all cars must undergo the weighing procedure.

At the end of the race, cars will be selected at random to undergo the weighing procedure. The FIA technical delegate will inform the driver that his car has been selected for weighing.

- iii) Having been signalled that his car has been selected for weighing, the driver will proceed directly to the weighing area with ready-to-move mode deactivated and the white light switched off.
- iv) The car will then be weighed and the result given to the driver in writing.
- v) If the car is unable to reach the weighing area under its own power, it will be placed under the exclusive control of the marshals, who will take the car to be weighed.
- vi) A car or driver may not leave the weighing area without the consent of the FIA technical delegate.
- vii) If a car stops on the circuit and the driver leaves the car, he must go to the weighing area immediately on his return to the pits in order for his weight to be established.

- b) After any practice session and the race, each car crossing the Line may be weighed.

If a driver wishes to leave his car before it is weighed he must ask the technical delegate to weigh him in order that this weight may be added to that of the car. The technical delegate will then tell the driver his weight and, once the driver leaves parc fermé, this will be deemed implicit acceptance of the figure. The minimum race weight must be 888 kg with the driver.

- c) The relevant car may be excluded should its weight be less than that specified in Article 5.1 of the Technical Regulations when weighed under a) or b) above, save where the deficiency in weight results from the accidental loss of a component of the car.
- d) No solid, liquid, gas or other substance or matter of whatsoever nature may be added to, placed on, or removed from a car after it has been selected for weighing or has finished the post-race scrutineering or during the weighing procedure (except by a scrutineer when acting in his official capacity).
- e) Only scrutineers and officials may enter the weighing area. No intervention of any kind is allowed there unless authorised by such officials.

- 26.2 In the event of any breach of these provisions for the weighing of cars the stewards may drop the driver such number of grid positions as they consider appropriate or exclude him from the race.

27) GENERAL CAR AND PERSONNEL REQUIREMENTS

- 27.1 Electromagnetic radiation between 5 and 6 GHz is forbidden save with the written consent of the FIA
- 27.2 The approved Accident Data Recorder (ADR) must be fitted to the car and be in working order at all times during the Event. At any time following an accident or incident, competitors must make the data recorder available and accessible to the FIA. This unit must be used throughout the Championship by each competitor entered for the season. This unit must be installed in strict compliance with the relevant instructions and must work at all times during the Event.
- 27.3 All cars must be fitted with a car positioning system and a telemetry system which have been manufactured by the FIA designated supplier to a specification determined by the FIA. No other parts which, in the opinion of the FIA, are capable of performing a similar function may be fitted to any car.
- 27.4 During the entire Event, no screen, cover or other obstruction which in any way obscures any part of a car will be allowed at any time in the paddock, garages, pit lane or grid, unless it is clear any such covers are needed solely for mechanical reasons, which could, for example, include protecting against fire.

In addition to the above, the following are specifically not permitted:

- a) Motor, gearbox or radiator covers whilst these parts are being changed or moved around the garage.

- b) Covers over spare wings when they are on a stand in the pit lane not being used.
- c) Parts such as (but not limited to) spare floors, charger units or tool trolleys may not be used as an obstruction.

The following are permitted:

- d) Covers which are placed over damaged cars or components.
- e) A tool tray, no more than 50mm deep, placed on top of the rear wing.
- f) Warming or heat retaining covers for the motor, batteries and gearbox on the grid.
- g) A cover over the car in the team's garage overnight.
- h) A cover over the car in the pit lane or grid if it is raining.

27.5 For each competitor, the number of operational staff members able to work on the cars at an Event must not exceed 12. Each will wear clearly visible and specific identification.

A maximum of 4 support staff per competitor, made available by the manufacturers, will be able to work on the cars. Each will wear clearly visible and specific identification.

All these staff will have access to the reserved areas from the start of initial scrutineering until three hours after the start of the race.

27.6 During an event, the teams shall access the cars during the time period specified in the supplementary regulations.

28) SPARE CARS, MOTORS, BATTERIES, GEARBOX

28.1 Each driver must use two cars at each Event. Spare cars are not permitted. However, any part of the car (excluding the survival cell) may be changed at any time during the Event.

28.2 The decision whether a car has been repaired will be taken by the stewards, based upon a report by the technical delegate.

28.3 Any car which has passed initial scrutineering may not be removed from the confines of the circuit during the remainder of the Event.

28.4 Each driver shall use no more than one motor, one gearbox and one battery pack per car for the entire season.

Unless the driver fails to finish a race (or is unable to start a race for reasons other than a penalty imposed by the stewards) the motor, the gearbox or the battery pack fitted in the car at the end of the first Event must remain in it for the whole of the Championship. Any driver who fails to finish a race, for reasons which the technical delegate accepts as being beyond the control of the team or driver, may start the following race with a different motor, gearbox or battery pack without a penalty being incurred. Any such motor, gearbox or battery pack must then remain in the car for the remainder of that Event and the whole of the Championship.

Should a driver use a replacement motor, gearbox or battery pack, he will drop 10 places on the starting grid for the next race in which he takes part.

28.5 After consultation with the relevant motor, gearbox or battery pack supplier the FIA will attach seals to each motor, gearbox or battery pack prior to it being used for the first time at an Event in order to ensure that no significant moving parts can be rebuilt or replaced.

28.6 Other than the straightforward replacement of one motor, gearbox or battery pack unit with another, a change will also be deemed to have taken place if any of the FIA seals are damaged or removed from the original motor, gearbox or battery pack after it has been used for the first time in any practice session or race.

29) ELECTRICITY, CHARGING

- 29.1** To charge the cars, only energy supplied by the supplier designated by the Event organiser and approved by the FIA shall be used during the Event.
- All competitors will be provided with the energy and the plug-in system specification in advance of each Event.
- Any alteration to the specification of the energy supplied and/or of the plug-in system may result in exclusion from the Event.
- 29.2** Only two individual charging units per competitor will be allowed at an event and will be sealed by the technical delegate. Only these charging units can be connected to the Event plug in system. Charging units can only be powered by energy supplied by the Event organiser.
- 29.3** Charging time is defined as follow:
- From 1:00 pm to 11:00 pm on the Friday before the event
 - From 6:30 am to 8:00 pm on the day of the event, except during Qualifying, Qualifying Parc Fermé, Race and Race Parc Fermé.

30) GENERAL SAFETY

- 30.1** Official instructions will be given to drivers by means of the signals laid out in the Code. Competitors must not use flags or lights similar in any way whatsoever to these.
- 30.2** Drivers are strictly forbidden to drive their car in the opposite direction to the race unless this is absolutely necessary in order to move the car from a dangerous position. A car may only be pushed to remove it from a dangerous position as directed by the marshals.
- 30.3** Any driver intending to leave the track or to go to his pit or the paddock area must signal his intention to do so in good time, making sure that he can do this without danger.
- 30.4** During practice, qualifying and the race, drivers may use only the track and must at all times observe the provisions of the Code relating to driving behaviour on circuits.
- 30.5** Other than by driving on the track, competitors are not permitted to attempt to alter the grip of any part of the track surface.
- 30.6** If a car stops on the track, it shall be the duty of the marshals to remove it as quickly as possible so that its presence does not constitute a danger or hinder other competitors. If any mechanical assistance received during the race results in the car re-joining the stewards may exclude him from the race (other than under Articles 30.13(d) or 39.3).
- 30.7** A driver who abandons his car must switch off the Driver Master Switch and leave it with the steering wheel in place.
- 30.8** Repairs to a car may be carried out only in the garage.
- 30.9** At each pit, the organiser must make available two fire-specific extinguishers of 5 kg capacity according to specifications determined by the FIA Safety Department, and ensure that they work properly.
- 30.10** Save as specifically authorised by the Code or these Sporting Regulations, no one except the driver may touch a stopped car unless it is in the paddock, the teams designated garage area, the pit lane or on the starting grid.
- 30.11** At no time may a car be reversed in the pit lane under its own power.
- 30.12** At no time may a car be driven unnecessarily slowly, erratically or in a manner which could be deemed potentially dangerous to other drivers or any other person. This will apply whether any such car is being driven on the track, the pit entry or the pit lane.
- 30.13** During the periods commencing five minutes prior to and ending five minutes after every practice session and the periods between the commencement of the formation lap which immediately precedes each race and the time when the last car enters the parc fermé, no one is allowed on the track, the pit entry or the pit exit with the exception of:
- a) Marshals or other authorised personnel in the execution of their duty.
 - b) Drivers when driving or on foot, having first received permission to do so from a marshal.
 - c) Team personnel when either pushing a car or clearing equipment from the grid after all cars able to do so have left the grid on the formation lap.
 - d) Team personnel when assisting marshals to remove a car from the grid after the start of the race.
 - e) Team personnel working on a car on the grid during a race suspension in accordance with Article 38.9b.
- 30.14** Drivers taking part in practice sessions and the races must always wear the clothes, helmet and FHR specified in the Code. Crash helmets complying with FIA Standard 8860-2004 are mandatory.
- 30.15** A speed limit of a minimum of 45 km/h and a maximum of 50 km/h will be enforced in the pit lane. Except in the race, any driver who does not respect the limits will be fined €100 for each km/h under or above the relevant limit. During the race, the stewards or race director may impose either of the penalties under Article 16.3 a) or b) on any driver who exceeds the limit.

- 30.16 If a driver has serious mechanical difficulties during a practice session or the race he must leave the track as soon as it is safe to do so.
- 30.17 The car's upper white light and rear red light must be illuminated at all times whenever the ready to move mode is on. It shall be at the discretion of the race director to decide if a driver should be stopped because one or both of his lights is not working. Should a car be stopped in this way, it may re-join when the fault has been rectified.
- 30.18 Only three team members plus the Team Principal per participating driver (all of whom shall have been issued with and wearing special identification) are allowed in the signalling area during practice and the race.
- People under 14 years of age are not allowed in the pit lane.
- 30.19 Animals, except those which may have been expressly authorised by the Organisers for use by security services, are forbidden in the pit area and on the track and in any spectator area.
- 30.20 The race director, the clerk of the course or the FIA medical delegate can require a driver to have a medical examination at any time during an Event; this medical examination may include an anti-doping test (ISC – Appendix L, Chapter II, Article 4).
- 30.21 Failure to comply with the general safety requirements of the Code or these Sporting Regulations may result in the exclusion of the car and driver concerned from the Event.

31) PRACTICE SESSIONS

- 31.1 Save where these Sporting Regulations require otherwise, pit lane and track discipline and safety measures will be the same for all practice sessions as for the race. In every practice session, cars will be deemed to be in conformity with the technical regulations.
- 31.2 During all practices there will be a green and a red light at the end of the pit lane. Cars may only leave the pit lane when the green light is on. Additionally, a blue flag and/or a flashing blue light will be shown in the pit exit to warn drivers leaving the pit lane if cars are approaching on the track.
- 31.3 In the event of a driving infringement during any practice session the Stewards may drop the driver such number of grid positions as they consider appropriate. Unless it is completely clear that a driver committed a driving infringement any such incident will normally be investigated after the relevant session.

Where appropriate, regard will also be given to the provisions of Article 18.1.

- 31.4 Any driver taking part in any practice session who, in the opinion of the stewards, stops unnecessarily on the circuit or unnecessarily impedes another driver shall be subject to the penalties referred to in Article 31.4.
- 31.5 Should it become necessary to stop any practice session because the circuit is blocked by an accident or because weather or other conditions make it dangerous to continue, the race director will order red flags to be shown at all marshal posts and the abort lights to be shown at the Line.

When the signal is given to stop, all cars shall immediately reduce speed and proceed slowly back to the pit lane, and all cars abandoned on the track will be removed to a safe place.

At the end of each practice session no driver may cross the Line more than once.

- 31.6 The race director may interrupt practice as often and for as long as he thinks necessary to clear the track or to allow the recovery of a car. However, only during qualifying practice will the session be extended as a result.

Should one or more sessions be thus interrupted, no protest can be accepted as to the possible effects of the interruption on the qualification of drivers admitted to start.

32) NON-QUALIFYING PRACTICE SESSIONS

- 32.1 Two free non-qualifying practice sessions will take place on the morning of the day of the race. The first will have a maximum duration of 45 minutes. The second will begin at least 30 minutes after the end of the first session and will have a maximum duration of 30 minutes.
- 32.2 For the non-qualifying practice sessions, two cars will be allowed with a maximum total power of 200 kW going out of the RESS.
- 32.3 No driver may start in the race without taking part in at least one non-qualifying practice session.
- 32.4 There will be no Parc Ferme after the non-qualifying practices. Technical Delegates may randomly control any car during or at the end of the practices.

33) QUALIFYING PRACTICE SESSIONS

- 33.1 One qualifying session of no more than 90 minutes duration divided into four groups of five cars each will take place on the day of the race at least two hours after the end of the non-qualifying practice session.
- 33.2 The starting order of the drivers will be determined by a lottery system. Four groups of five drivers will be formed. Each group will have ten minutes of track time. Each driver may use only one car. For this qualifying practice session, the pit out line can be crossed only once during the session. At the end of his session, each driver will return to the pit lane and will place his car in parc fermé according to the instructions of the marshals.
- 33.3 Any driver whose car stops on the circuit during the qualifying will not be permitted to take any further part in the session. Any car which stops on the circuit during the qualifying session and which is returned to the pits before the end of the session will be held in parc fermé until the end of the session.
- 33.4 For the qualifying practice session, one car only will be allowed with a maximum total power of 200 kW going out of the RESS.

34) POST QUALIFYING PARC FERMÉ

- 34.1 Each car used by each driver will be deemed to be in parc fermé from the time at which the car leaves the pit lane for the first time during qualifying practice until thirty minutes after the official results are posted, unless specifically requested otherwise by the stewards. Any car which fails to leave the pit lane during qualifying practice will be deemed to be in parc fermé at the end of the session in which it should have participated.

35) THE GRID

- 35.1 At the end of qualifying practice, the fastest time achieved by each driver will be officially published.
- 35.2 At Events, the grid for the race will be drawn up in the order of the fastest qualifying time achieved by each driver in the qualifying practice session. The grid will be published one hour before the start of the race.

Any driver who is unable to start for any reason whatsoever must inform the stewards at the earliest opportunity and, in any case, no later than one hour before the start of the formation lap.

If one or more cars are withdrawn, the starting grid will be closed up accordingly and the final starting grid confirmed 30 minutes before the start of the race. Should two or more drivers have identical times, priority will be given to the one who set it first.

- 35.3 The fastest driver will start the race from pole position on the grid designated by the FIA Circuits Department.

- 35.4 Any driver whose best qualifying lap exceeds 110% of the pole position time will not be allowed to take part in the race. Under exceptional circumstances however, which may include setting a suitable lap time in a previous non-qualifying practice session, the stewards may permit the car to start the race.

Should there be more than one driver accepted in this manner, their order will be determined by the stewards.

- 35.5 The grid will be in a staggered 1 x 1 formation and the rows on the grid will be separated by 8 metres.

36) STARTING PROCEDURE

- 36.1 30 minutes before the start of the formation lap the pit exit will be opened and cars will be permitted to leave the pit lane. The cars must then be pushed by their teams to the pre-grid.

- 36.2 22 minutes before the start of the race, a warning signal will be given indicating that the end of the pit lane will be closed in two minutes.

20 minutes before the start of the race the end of the pit lane will be closed and a second warning signal will be given. Any car which is still in the pit lane can start from the end of the pit lane. If more than one car is affected they must line up in the order in which they qualified. However, any car reaching the end of the pit lane after the five minute signal must start behind any car already at the pit exit.

All such cars may then join the race once the whole field has passed the end of the pit lane for the first time after the start.

- 36.3 The approach of the start will be announced by signals shown ten (10) minutes, five (5) minutes, three (3) minutes, one (1) minute and fifteen (15) seconds before the start of the race, each of which will be accompanied by an audible warning.

When the five (5) minute signal is shown, everybody except drivers, officials and team technical staff must leave the grid.

- 36.4 When the three (3) minute signal is shown all cars on the grid must have their wheels fitted, after this signal wheels may only be removed in the pit lane, or on the grid during a race suspension.

A penalty under Article 16.3(b) will be imposed on any driver whose car did not have all its wheels fully fitted at the three minute signal.

- 36.5 When the one (1) minute signal is shown, motors should be energised and all team personnel must leave the grid by the time the fifteen (15) second signal is given taking all equipment with them. If any driver needs assistance after the fifteen (15) second signal he must raise his arm and, when the remainder of the cars able to do so have left the grid, marshals will be instructed to push the car into the pit lane. In this case, marshals with yellow flags will stand beside any car (or cars) concerned to warn drivers behind.

- 36.6 When the green lights are illuminated, the cars will begin the formation lap with the pole position driver leading.

When leaving the grid all drivers must respect the pit lane speed limit until they pass pole position.

Marshals will be instructed to push any car (or cars) which remain on the grid into the pit lane by the fastest route immediately after cars able to do so have left the grid. Any driver being pushed from the grid may not attempt to start the car and must follow the instructions of the marshals.

- 36.7 During the formation lap practice starts are forbidden and the formation must be kept as tight as possible.

- 36.8 Overtaking during the formation lap is only permitted if a car is delayed and cars behind cannot avoid passing it without unduly delaying the remainder of the field. In this case, drivers may only overtake to re-establish the original starting order. Any driver delayed in this way, and who is unable to re-establish the original starting order before he reaches the first safety car line, must enter the pit lane and start from the end of the pit lane as specified in Article 36.2.

- 36.9** When the cars come back to the grid at the end of the formation lap, they will stop on their respective grid positions, keeping their motors energised.

There will be a standing start, the signal being given by means of lights activated by the permanent starter.

Once all the cars have come to a halt The five second light will appear followed by the four, three, two and one second lights. At any time after the one second light appears, the race will be started by extinguishing all red lights.

- 36.10** Unless specifically authorised by the FIA race director, during the start of a race the pit wall must be kept free of all persons with the exception of officials and fire marshals.

- 36.11** If, after returning to the starting grid at the end of the formation lap a problem arises, the following procedures shall apply:

- a) If a car develops a problem that could endanger the start the driver must immediately raise his hands above his head and the marshal responsible for that row must immediately wave a yellow flag. If the race director decides the start should be delayed the green lights will be illuminated two seconds after the abort lights are switched on, a board saying "EXTRA FORMATION LAP" will be displayed and all cars able to do so must complete a further formation lap whilst the car which developed the problem is moved into the pit lane.

When leaving the grid to complete the extra formation lap all drivers must respect the pit lane speed limit until they pass pole position.

The team may then attempt to rectify the problem and, if successful, the car may then start from the end of the pit lane. Should there be more than one car involved their starting order will be determined by the order in which they reached the end of the pit lane.

Every time this happens the race will be shortened by one lap.

- b) If any other problem arises, and if the race director decides the start should be delayed, the following procedures shall apply:

- i) If the race has not been started, the abort lights will be switched on, a board saying "DELAYED START" will be displayed, all motors will be stopped and the new formation lap will start five minutes later with the race distance reduced by one lap. The next signal will be the three minute signal.

Tyre changing on the grid is not permitted during such a delay.

Every time this happens the race will be shortened by one lap.

- ii) If the race has been started the marshals alongside the grid will wave their yellow flags to inform the drivers that a car is stationary on the grid.

- iii) If, after the start, a car is immobilised on the starting grid, it shall be the duty of the marshals to push it into the pit lane by the fastest route. Any driver being pushed from the grid may not attempt to start the car.

- iv) Once the car is in the pit lane his mechanics may attempt to start it, if successful the driver may re-join the race. The driver and mechanics must follow the instructions of the track marshals at all times during such a procedure.

- 36.12** Should Article 36.11 apply, the race will nevertheless count for the Championship no matter how often the procedure is repeated, or how much the race is shortened as a result.

- 36.13** Either of the penalties under Articles 16.3a) or b) will be imposed for a false start.

- 36.14** Only in the following cases will any variation in the start procedure be allowed:

- a) If it starts to rain after the five minute signal but before the race is started and, in the opinion of the race director teams should be given the opportunity to make the setup changes, the abort lights will be shown on the Line and the starting procedure will begin again at the ten minute point.

- b) If the start of the race is imminent and, in the opinion of the race director, the volume of water on the track is such that it is unsafe to race, the abort lights will be shown on the Line and information concerning the likely delay will be displayed on the timing monitors. Once the start time is known at least ten minutes warning will be given.
- c) If the race is started behind the safety car, Article 38.15 will apply.

36.15 The stewards may use any video or electronic means to assist them in reaching a decision. The stewards may overrule judges of fact. A breach of the provisions of the Code or these Sporting Regulations relating to the starting procedure may result in the exclusion of the car and driver concerned from the Event.

37) THE RACE

37.1 During the race, drivers leaving the pit lane may only do so when the light at the end of the pit lane is green and on their own responsibility. A marshal with a blue flag and/or a flashing blue light will also warn the driver if cars are approaching on the track.

37.2 The race will be organised at least three hours after the end of the qualifying practice session.

The distance of all races, from the start signal to the chequered flag, will be of a minimum of 60 km and a maximum time of sixty (60) minutes plus one additional lap with a minimum of one mandatory change of cars. The number of laps will be established and announced in the supplementary regulations of the events.

37.3 FanBoost will be allocated to the three drivers who have received the greatest number of votes on the FE app and on other social media.

For each of their cars, the winning drivers will be allocated a boost of power exceeding 170 kW in 1 shot for 5 seconds.

The three drivers who will benefit from Fanboost will be notified by the Chairman of Stewards a maximum of 15 minutes before the start of the race. More details are specified in Appendix 3.

37.4 Each driver shall use his two respective cars. The change of car shall take place in his box.

37.5 For each race, a reference time for the mandatory change of car will be established. This reference time will take into account the time taken between the Pit entry and Pit exit loops including the time required for the obligatory stop to change cars.

The total time will be published in a bulletin from the FIA stewards the evening before the event

The mandatory change of car must take place inside the box allocated to the driver. It will be performed observing as a minimum the above-mentioned reference time, which shall be published in the stewards' bulletin. A maximum of two (2) team personnel can help the driver.

Before leaving his pit, the driver must fasten his safety harness and comply with the safety rules.

Any other pit stops must be made in front of each team's designated pit or location under the responsibility of the designated Team Manager and no reference time will apply.

A timing loop will be positioned at the Pit entrance and Pit exit to control the duration of stops.

37.6 It is not permitted to change a car during the race.

37.7 Both cars used by each driver will be deemed to be in Parc Fermé after the first car crosses the finish line at the end of the race until sixty (60) minutes after the official results are posted, except in the case of a specific request from the stewards.

38) SAFETY CAR

38.1 The safety car will be driven by an FIA approved driver and will carry an FIA approved observer capable of recognising all the competing cars who is in permanent radio contact with race control.

- 38.2** Twenty minutes before the start of the formation lap the safety car will take up position at the front of the grid and remain there until the five minute signal is given. At this point (except under Article 38.15 below) it will cover a whole lap of the circuit and take up position.
- 38.3** The safety car may be brought into operation to neutralise a race upon the order of the race director. It will be used only if competitors or officials are in immediate physical danger but the circumstances are not such as to necessitate suspending the race.
- 38.4** When the order is given to deploy the safety car the message "SAFETY CAR DEPLOYED" will, where possible, be displayed on the timing monitors and all marshal's posts will display waved yellow flags and "SC" boards for the duration of the intervention.
- 38.5** No car may be driven unnecessarily slowly, erratically or in a manner which could be deemed potentially dangerous to other drivers or any other person at any time whilst the safety car is deployed. This will apply whether any such car is being driven on the track, the pit entry or the pit lane.
- 38.6** The safety car will join the track with its orange lights illuminated and will do so regardless of where the race leader is.
- 38.7** All competing cars must reduce speed and form up in line behind the safety car no more than ten car lengths apart.
- 38.8** With the exception of the cases listed under a) to h) below, no driver may overtake another car on the track, including the safety car, until he passes the first safety car line for the first time when the safety car is returning to the pits. However, if the safety car is still deployed at the beginning of the last lap, or is deployed during the last lap, Article 38.14 will apply.

The exceptions are:

- a) If a driver is signalled to do so from the safety car.
 - b) Under Articles 38.12 or 38.15 below.
 - c) When entering the pits a driver may pass another car remaining on the track, including the safety car, after he has reached the first safety car line.
 - d) When leaving the pits a driver may overtake, or be overtaken by, another car on the track before he reaches the second safety car line.
 - e) When the safety car is returning to the pits it may be overtaken by cars on the track once it has reached the first safety car line.
 - f) Whilst in the pit entry, pit lane or pit exit a driver may overtake another car which is also in one of these three areas.
 - g) Any car stopping in its designated garage area whilst the safety car is using the pit lane (see Article 38.11 below) may be overtaken.
 - h) If any car slows with an obvious problem.
- 38.9** When ordered to do so by the race director the observer in the car will use a green light to signal to any cars between it and the race leader that they should pass. These cars will continue at reduced speed and without overtaking until they reach the line of cars behind the safety car.
- 38.10** The safety car shall be used at least until the leader is behind it and all remaining cars are lined up behind him.
- Once behind the safety car, the race leader must keep within ten car lengths of it (except under Article 38.12 below).
- 38.11** Under certain circumstances the race director may ask the safety car to use the pit lane. In these cases, and provided its orange lights remain illuminated, all cars must follow it into the pit lane without overtaking. Any car entering the pit lane under these circumstances may stop at its designated garage area.
- 38.12** When the race director decides it is safe to call in the safety car, the message "SAFETY CAR IN THIS LAP" will, where possible, be displayed on the timing monitors and the car's orange lights will be

extinguished. This will be the signal to the teams and drivers that it will be entering the pit lane at the end of that lap.

At this point the first car in line behind the safety car may dictate the pace and, if necessary, fall more than ten car lengths behind it.

In order to avoid the likelihood of accidents before the safety car returns to the pits, from the point at which the lights on the car are turned out drivers must proceed at a pace which involves no erratic acceleration or braking nor any other manoeuvre which is likely to endanger other drivers or impede the restart.

As the safety car is approaching the pit entry the yellow flags and SC boards will be withdrawn and, other than on the last lap of the race, replaced by waved green flags with green lights at the Line. These will be displayed until the last car crosses the Line.

38.13 Each lap completed while the safety car is deployed will be counted as a race lap.

38.14 If the safety car is still deployed at the beginning of the last lap, or is deployed during the last lap, it will enter the pit lane at the end of the lap and the cars will take the chequered flag as normal without overtaking.

38.15 Under certain circumstances the race may be started behind the safety car or resumed in accordance with Article 40.5(a). In either case, at the ten minutes signal its orange lights will be illuminated, this being the signal to the drivers that the race will be started (or resumed) behind the safety car.

When the green lights are illuminated the safety car will leave the grid and all drivers must follow in grid order, no more than ten car lengths apart, and must respect the pit lane speed limit until they pass pole position. During a race start there will be no formation lap and the race will start when the green lights are illuminated.

Overtaking is only permitted if:

- a) A car is delayed when leaving the grid and cars behind cannot avoid passing it without unduly delaying the remainder of the field, or
- b) There is more than one car starting from the pit lane and one of them is unduly delayed.

In either case drivers may only overtake to re-establish the original starting order or the order the cars at the pit exit were in when the race was started.

Any driver delayed in either way, and who is unable to re-establish the original starting order before he reaches the first safety car line, must enter the pit lane and may only join the race once the whole field has passed the end of the pit lane.

39) SUSPENDING A RACE

39.1 Should it become necessary to suspend the race because the circuit is blocked by an accident or because weather or other conditions make it dangerous to continue, the race director will order red flags to be shown at all marshal posts and the abort lights to be shown at the Line.

39.2 When the signal is given overtaking is forbidden, the pit exit will be closed and all cars must proceed slowly to the starting grid. The first car to arrive on the grid should occupy pole position and others should fill the remaining grid positions in the order they arrive.

If the race is suspended during a safety car intervention, and the safety car is directed into the pit lane, cars should stop in a line behind the safety car in the fast lane of the pits.

39.3 Any cars unable to return to the grid as a result of the track being blocked will be brought back when the track is cleared and will be arranged in the order they occupied before the race was suspended.

In all cases the order will be taken at the last point at which it was possible to determine the position of all cars. All such cars will then be permitted to resume the race.

The Safety Car will then be driven to the front of the grid.

39.4 Whilst the race is suspended:

- a) Neither the race nor the timekeeping system will stop; however, where the Event timetable can accommodate it, the length of the race suspension will be added to the maximum time for the race in question.
- b) Cars may be worked on once they have stopped on the grid or entered the pits but any such work must not impede the resumption of the race.
- c) Only team members and officials will be permitted on the grid.

39.5 Cars may not enter the pit lane when the race is suspended. A penalty under Article 16.3(a) will be imposed on any driver who enters the pit lane or whose car is pushed from the grid to the pit lane after the race has been suspended. Any car which was in the pit entry or pit lane at the time the race was suspended will not incur a penalty. However, if the race has been suspended in the pit lane (see Article 39.2 (a) penalty will only be imposed on any driver whose car is moved from the fast lane to any other part of the pit lane.

All cars in the pit lane will be permitted to leave the pits once the race has been resumed and, subject to the above, any car intending to resume the race from the pit exit may do so in the order they got there under their own power, unless another car was unduly delayed.

At all times drivers must follow the directions of the marshals.

40) RESUMING A RACE

40.1 The delay will be kept as short as possible and as soon as a resumption time is known teams will be informed via the timing monitors where possible; in all cases at least ten minutes warning will be given.

40.2 Signals will be shown ten minutes, five minutes, three minutes, one minute and fifteen seconds before the resumption and each of these will be accompanied by an audible warning.

40.3 When the three minute signal is shown all cars on the grid must have their wheels fitted. After this signal wheels may only be removed in the pit lane, or on the grid during a further race suspension. If the race has been suspended in the pit lane (see Article 39.2) all cars in the fast lane must have their wheels fitted at the three minute signal.

A penalty under Article 16.3(b) will be imposed on any driver whose car did not have all its wheels fully fitted at the three minute signal.

At the two minute signal any cars between the safety car and the leader will be waved off to complete a further lap, without overtaking, and join the line of cars behind the safety car.

40.4 When the one minute signal is shown, Article 36.5 may be applied.

40.5 The race will be resumed behind the safety car when the green lights are illuminated. The safety car will enter the pits after one lap unless:

- a) The race is being resumed in wet conditions and the race director deems more than one lap necessary, in which case see Article 38.15.
- b) All cars are not yet in a line behind the safety car.
- c) Team personnel are still clearing the grid.
- d) A further incident occurs necessitating another intervention.

When the green lights are illuminated, the safety car will leave the grid and all drivers must follow, no more than ten car lengths apart, and must respect the pit lane speed limit until they pass pole position. Soon after the last car in line behind the safety car passes the end of the pit lane (including any cars which were waved off under Article 40.3 above) the pit exit light will be turned green, any car in the pit lane may then enter the track and join the line of cars behind the safety car.

40.6 Overtaking is only permitted if:

- a) A car is delayed when leaving the grid and cars behind cannot avoid passing it without unduly delaying the remainder of the field, or

b) There is more than one car starting from the pit lane and one of them is unduly delayed.

In either case drivers may only overtake to re-establish the order before the race was suspended or the order the cars at the pit exit were in when the race was resumed.

Any driver delayed in either way, and who is unable to re-establish the original starting order before he reaches the first safety car line, must enter the pit lane and may only re-join the race once the whole field has passed the end of the pit lane.

40.7 Either of the penalties under Article 16.3a) or b) will be imposed on any driver who, in the opinion of the stewards, unnecessarily overtook another car during the lap.

During this lap Articles 38.12, 38.13, 38.14 and 38.15 will apply.

40.8 If the race cannot be resumed the results will be taken at the end of the penultimate lap before the lap during which the signal to suspend the race was given.

41) FINISH

41.1 The end-of-race signal will be given at the Line as soon as the leading car has covered the full race distance in accordance with Article 5.4.

41.2 Should for any reason the end-of-race signal be given before the leading car completes the scheduled number of laps, the race will be deemed to have finished when the leading car last crossed the Line before the signal was given. Should the end-of-race signal be delayed for any reason, the race will be deemed to have finished when it should have finished.

41.3 After receiving the end-of-race signal all cars must proceed on the circuit directly to the parc fermé without any unnecessary delay, without overtaking (unless clearly necessary), without receiving any object whatsoever (except national flag for the winner) and without any assistance (except that of the marshals, if necessary).

Any classified car which cannot reach the parc fermé under its own power will be placed under the exclusive control of the marshals who will take the car to the parc fermé.

42) PARC FERME + Quarantine Area

42.1 Only those officials charged with supervision may enter the Parc Fermé. One mechanic per car is allowed to enter the Parc Fermé once, just to plug an auxiliary battery on the car and to fit a cooling system. No other intervention of any kind is allowed there unless authorised by such officials.

42.2 When the parc fermé is in use, parc fermé regulations will apply in the area between the Line and the parc fermé entrance.

42.3 The parc fermé shall be sufficiently large and secure that no unauthorised persons can gain access to it.

43) CLASSIFICATION

43.1 The end-of-race signal will be given at the line as soon as the leading car has covered the full race distance in accordance with Art 5.4. All cars will be classified taking into account the number of complete laps they have covered, and for those which have completed the same number of laps, the order in which they crossed the Line.

43.2 Cars having covered less than 90% of the number of laps covered by the winner (rounded down to the nearest whole number of laps), will not be classified.

43.3 The official classification will be published after the race. It will be the only valid result, subject to any amendments which may be made under the Code and these Sporting Regulations.

44) PODIUM CEREMONY

- 44.1 The drivers finishing the races in 1st, 2nd and 3rd positions and a representative of the winning team must attend the prize-giving ceremony on the podium and immediately thereafter make themselves available for the purpose of television interviews and the press conference in the media centre.

45) PRESS CONFERENCE AND PROMOTION AFTER THE RACE

- 45.1 Upon request, all registered drivers are obliged to attend free of charge all press conferences organised by the FIA. The following obligations must in addition be respected:

Immediately after qualification and/or prize giving the first three classified drivers of the race will be required to make themselves available for a press conference (at a location specified in the supplementary regulations). All of these three drivers are obliged to attend this press conference.

The drivers must wear their closed overalls and designated caps during the press conferences. Failure to attend the press conference or any lateness will result in a penalty of €3000. This penalty will be increased by another €1000 for any additional infringement of this kind.

- 45.2 Drivers must take part in any promotional activity requested by the Promoter such as autograph sessions, prize giving, press conferences, pit road walkabouts and pre-race parades.

The drivers, competitors and manufacturers give the right to the FIA to use their name for any promotional, advertising, publicity and public relations purpose, for the promotion of the Championship. Use of the Championship logo by the competitors, manufacturers and drivers or their agents or representatives is prohibited other than by prior permission in writing from the FIA.



FEDERATION INTERNATIONALE DE L'AUTOMOBILE

2014 Formula E Championship

EVENT (COUNTRY CODE) – DATE

APPENDIX 1

Information required under Article 9.2 of the FIA Formula E Championship Sporting Regulations

PART A

1. Name and address of the National Sporting Authority (ASN)

National Sporting Authority:

Address:

Telephone:

Telefax:

E-Mail:

2. Name and address of the organiser

Organiser's name:

Address:

Telephone:

Telefax:

E-Mail:

3. Date and place of the Event:

4. Start time of the administrative checks.

- Scrutineering:
- Sporting checks:

5. Start time of each race

	Race 1
Date	
Time	

6. Start time of each support race

	<u>Race 1</u>
<u>Date</u>	
<u>Time</u>	

	<u>Race 2</u>
<u>Date</u>	
<u>Time</u>	

7. Address and telephone, fax number and e-mail to which enquiries can be addressed

Name:

Address:

Telephone:

Telefax:

E-Mail:

8. Details of the circuit, which must include:

- Location and how to get there:
- Length of one lap:
- Number of laps in each race:
- Direction:
- Location of pit exit in relation to line:
- Start line:
- Finish line:
- Pole position:
- Speed limit pit lane:
- Number of cars in compliance with the track licence to take part in:
- Starting mode:

9. Precise location at the circuit of:

- Stewards' Office :
- Race Director's Office:
- FIA Office:
- Sporting checks:
- Scrutineering, flat area and weighing:
- Parc fermé:
- Drivers' and competitors' Briefing:
- Official digital notice board:
- Winner's press conference:
- Press centre:
- Media accreditation center:

10. List of any supplementary trophies and special awards:

11. The names of the following officials of the Event appointed by the ASN:

- Stewards :
- Clerk of the Course :
- Secretary of the Event :
- Chief National Scrutineer :
- Chief National Medical Officer :

12. Any other item specific to the Event:

- Protest and appeal
 - Amount of protest fee :
 - Amount of appeal fee :
- General medical information
 - Medical Centre location :
 - Telephone number :
- Announcements by Race Control :
- White line at the end of the pit lane :
- Additional sign at the start and finish podium :
- Technical Equipment of the teams at the pit wall :

13. Car access:

- Car access: From Friday 8:00 am to Sunday 8:00 pm

PART B (TO BE COMPLETED BY THE FIA)

- STEWARD(S) OF THE MEETING :
- RACE DIRECTOR :
- TECHNICAL DELEGATE :
- RACE DIRECTOR ASSISTANT :
- SCRUTINEER :
- SCRUTINEER :
- SCRUTINEER :
- SAFETY DELEGATE :
- PERMANENT STARTER :
- MEDICAL DELEGATE :
- PRESS DELEGATE :
- OBSERVER :
- SAFETY CAR DRIVER :
- MEDICAL CAR DRIVER :
- OTHERS :

PART C

Detailed timetable

PART D

Organisation Agreement

Available from the FIA Secretary

APPENDIX 2

PODIUM CEREMONY

1. MASTER OF CEREMONIES

A master of ceremonies will be appointed to conduct and take responsibility for the entire podium ceremony.

2. PODIUM

a) ROSTRUM AND DAIS

The dimensions of the dais must follow those found in the FIA graphic design manual.

The distance between the edge of the winner's dais and the retaining barrier of the podium should be a minimum of 120cm to provide a walkway.

The place where each person presenting a trophy should stand must be marked on the floor of the podium.

Trophies must be laid out on a single table on one side of the podium. The champagne must be on the dais.

b) FLAGS

Olympic Games style "flat flags" should be used. There must be a minimum space of 50cm behind the podium structure for the flag men.

c) FLOOR

The podium and steps should be covered in green or dark blue carpet.

3. ANTHEMS

a) The national anthem of the winning driver and winning team will be played. The Nationalities of the teams and drivers will be notified to the organiser by the FIA and will accord with Article 112 of the Code.

b) A suitable sound system should be installed to ensure that national anthems, (initiated by the master of ceremonies) are clearly heard with an audio link to the TV broadcast.

c) When the champagne shower begins, music should be played. This should not start until the presenters have left the podium.

d) A commentary of the podium ceremony should be broadcast to the general public from the platform erected for the TV cameras.

4. TROPHIES

Only four trophies will be presented during the podium ceremony:

a) Winning driver.

b) Second driver.

c) Third driver.

d) Winning Team

The trophies are free in design, but should reflect the importance of the Event. They will be provided by the ASN and must show:

a) The FIA Formula E Championship official logo.

- b) The official name of the event and/or the title sponsor logo.
- c) The driver's position.

The format of the trophies shall be:

- a) Winner's trophy - must visibly differ from the trophies awarded to the second and third drivers.
- b) Second and third drivers' trophies - may resemble one another.

The maximum weight per trophy must not exceed 5 kg. Trophies must be of a design that is capable of being handled and transported without damage.

5. SCENARIO

- a) Only three persons should be on the podium to present the trophies. In exceptional circumstances, the master of ceremonies may increase this to four.
- b) No police, bodyguards or persons not authorised by the master of ceremonies are allowed on the podium.
- c) The master of ceremonies will inform the TV and public address commentator of the names of the persons presenting the trophies.
- d) The master of ceremonies must be on the side of the podium where the trophies are located. The persons presenting the trophies will be on the other side. The master of ceremonies will hand the trophies to those presenting them.

6. TELEVISION

The ideal position for the TV camera is immediately opposite the podium and at the same height. Under no circumstances must there be a TV camera man on the podium.

7. PARC FERME

The parc fermé must be positioned as close as possible to the podium, preferably immediately below, with direct access.

As soon as all the cars have crossed the Line, a course car must go round the track to collect any driver who has finished in the first three but is stranded on the circuit.

The drivers must not be delayed in the parc fermé. One person, nominated by the master of ceremonies and in radio contact with him, will be responsible for moving the drivers from the parc fermé to the podium without delay. Only persons authorised by the master of ceremonies may make contact with the drivers before the end of any TV interviews.

8. PRESS ROOM

Immediately after the TV interviews, drivers must go to the press room for interviews.

9. WATER + TOWELS

3 bottles of water must be put in the parc fermé (no identification).

3 bottles of water must be put in the unilateral room (no identification).

3 towels must be available in the unilateral room.

No other drinks are permitted in the parc fermé or unilateral room.

10. PODIUM PROTOCOL

An invitation will be issued to each person attending the podium ceremony with clear instructions as to the procedure to follow.

APPENDIX 3

ORGANISATION RULES

Art	CONTENTS
1	DUTIES & AUTHORITIES
2	ADVERTISING SPACES & SERIES RIGHTS
3	PR & PROMOTION
4	PASSES
5	PADDOCK
6	ADR
7	MMM TELEMETRY
8	WEBSITES
9	FANBOOST
10	FORMS
11	OFFICIAL ADVERTISING

1. DUTIES & AUTHORITIES

The FE Manager will be designated by the Promoter in consultation with the FIA and will act as the general contact person for competitors, drivers and partners of the Series. He cooperates directly with the event Organisers/Promoters and carries out the duties listed below; he alone is authorised to give instructions and he must ensure that everything runs smoothly:

1. Preparation of administrative checks and submission of the corresponding lists to the event Organisers/Promoters.
2. Organising official FE testing.
3. Issuing the passes for FE access authorisation and parking depending on the area in which the event is taking place.
4. Appointment and planning of the location of the FE paddocks for the industry and for the participants, in cooperation with the event Organiser/Promoter.
5. Communicating to the competitors all information relevant to the running of the Series and the respective events.
6. Coordinating the official FE hospitality services.
7. Coordinating promotional events during events (e.g. autograph sessions) and outside
8. Coordinating the sponsoring and promotional activities of the Series partners.
9. Contracting TV stations to broadcast FE internationally.
10. Preparing and providing media analysis for industry and participants

2. ADVERTISING SPACES & SERIES RIGHTS

All advertising on/in cars and on drivers and teams must comply with the legal requirements of the country in which the race is taking place and must also comply with any national restrictions in force.

All competitors give the FE Promoter the right to fit one or several on-board cameras(s) to any car, provided that this meets the requirements of the technical delegate. No in-car cameras may be fitted other than those required by the FE Promoter.

If required by the FE Manager, all cars must have the official sticker on the dashboard, and this must be visible to a forward facing camera. The decision on the positioning of this sticker rests solely with the FE Manager. All other in-car advertising, including any on the driver's helmet and overalls, will be allowed only at the discretion of the Promoter. In the event of a dispute, the final decision rests with the Promoter.

All audio/visual rights are in accordance with the FIA regulations and all trademarks and copyrights relating to the Championship are the property of the FIA and shall be vested in the FIA.

The revenue from the sale of the Championship's rights/advertising spaces specified in the following will accrue solely to the benefit of the FE Promoter.

The FE Promoter reserves the right to modify the present provisions or to issue additional Championship rights during the season or to modify existing Championship rights subject to the prior approval of the FIA.

2.1 Car Liveries and drivers' overalls

In addition to Article 21 of the FE Championship Sporting Regulations, it should be stated that all car liveries and drivers' overalls liveries have to conform to chapter 11 of the present Organisation rules Agreement. Both drivers of a Team must have in substantially the same drivers' overalls.

2.2 Prize-giving Caps

Additionally to Article 45 of the FE Championship Sporting Regulations and the corresponding Appendix 2, it should be specified that all drivers are obliged to wear the caps issued by the FE Promoter after each race from the time they exit their car in the winners' parc fermé, throughout the entire duration of the prize-giving ceremony (except whilst the national anthems are being played), as well as during the winners' interviews; and they must keep their overalls closed. Failure to comply with this regulation will be reported to the stewards.

2.3 Podium

Additionally to the "Standard FE Event Organisation Rules", it should be specified that any kind of advertising on the podium is subject to the agreement of the FE Promoter.

2.4 Grid Girls and Grid Boards

Additionally to the "Standard FE Event Organisation Rules", it should be specified that any kind of advertising on the clothing of the grid girls, as well as on the grid boards, is subject to the agreement of the FE Promoter.

2.5 Merchandising, Licensing

The use of the official FE logo for merchandising articles and for any other commercial purpose must be agreed with the FE Promoter in detail.

3. PR & PROMOTION

3.1 All drivers and competitors must submit the completed "Media Guide registration for drivers/teams" form (see Appendix 2 of the present Organisation Rules) to the FE Manager by 30 June 2014.

3.2 Upon request, all drivers entered are obliged to attend, without payment, all activities such as photo shoots and autograph sessions, etc. that are organised by FE. Drivers failing to attend, or turning up late, will be reported to the stewards.

- 3.3** With the submission of the entry form, all drivers, competitors, teams and sponsors declare their consent for the use all of their rights in any media whatsoever (including, without limitation, moving pictures, digital images, print, radio, internet, merchandising for give-aways and retail sale) and publicity arising from their engagement in the Series for the marketing of the Series; this also applies after 2014, without any charge.
- 3.4** During the season, each competitor is obliged to participate with one car and/or one driver in three promotional events organised by FE, if required. A possible sharing of costs will be discussed between the respective team and the FE Promoter.
- 3.5** The data established by the official timekeeping are the property of the FIA.

4. PASSES

4.1 General conditions

In addition to Article 14 of the FE Championship Sporting Regulations, the following details regarding access authorisations are defined:

The FE Manager alone is entitled to issue personal passes with admission to the paddocks, the pits and the pit lane. The FE Manager alone is entitled to issue car passes.

All persons concerned in any way with an entered car, or present in any other capacity whatsoever in the paddock, pits, pit lane or on track, must wear the appropriate pass, which must be clearly visible at all times.

A pass may be used only by the person to whom it was issued and only for the purpose for which it was issued. Any exchange of passes or the copying or falsification of passes will, at the very least, entail that the person/s concerned must leave the circuit area immediately. This does not exclude further legal actions that can be taken by the FIA and/or FE Promoter.

4.2 Distribution

The number of passes and contingents valid for the FE qualifying rounds of the 2014 season are listed below.

All passes will be handed out on the Thursday of the first event. Details will be communicated via team info.

The FE Manager also reserves the right to modify the pass conditions during the season and to issue a limited number of additional passes for the pit lane and the pit wall, which would have to be displayed in these areas.

- Each competitor will receive the following personal permanent passes:
- Each competitor will receive the following personal permanent passes:

12x Operational passes	Access to FE paddock, pit lane, grid and allowed to work on the car.
12x Armbands	For operational staff allowed to work on the car (Does not afford admission to the event). They must be worn at all time.
6x Team passes	Access to FE paddock, pit lane and grid
6x guest passes	Access to FE paddock and grid
- Each driver will receive the following personal passes: 2x driver passes
- Each reserve driver will receive the following personal passes: 1x driver pass

- Each competitor is required to submit to the FE Manager a list that allocates each single ticket number to a specific member of the team.

5. PADDOCK

5.1 Racing Services

The FE Promoter alone has the right to nominate racing services that will be allocated an area in the paddocks for a service vehicle.

5.2 Service Tents

The FE paddock will not be available before the Friday 9.00 am.

The exact times will be communicated via team info before each event.

Cars are not allowed to enter the paddock before being asked to do so by the FE Organisation.

The following areas for team allocation in the paddock will be available free of charge for the teams:
16.0 x 12.0 meters (width x depth) or equivalent area

The position of these areas will be decided by the FE Manager, in cooperation with the respective Event Organiser.

All teams are obliged to keep their service tents/box open during the official event times (see timetable), in order to allow the fans to see the cars inside. The tents/box may be closed only with the approval of the FE Manager.

The dismantling of the tents/box is only allowed after the finish of the Main Race and the respective prize giving ceremony. If there is another race after the Main Race the dismantling can be delayed until the end of this race. If a team dismantles its tent/box during the Main Race without permission the competitor in question will be reported to the stewards.

All damage caused by the erection and/or dismantling of the tents/box, (pegs, damage of cables or asphalt, crop damage etc.) will be invoiced to those responsible by the race track or Promoter of the event.

5.3 Hospitality & Presentation Area,

The FE Promoter will run an official FE Hospitality operation that shall be appropriate for the appearance of the Championship and its competitors. It will be essential for the concept of this hospitality to have a certain basic number of people and, as a bare minimum, the FE drivers/their escorts and team officials using this facility. Therefore, at the first event, each competitor will receive, six (6) permanent hospitality passes (two allocated to the respective drivers, four allocated to the team) for the whole season, which will be invoiced to the competitor after each race weekend of the championship. The price per pass for each weekend will be at Promotor cost plus VAT (each pass is valid for one person and includes three main meals from the lunch the day prior to the event to the lunch the day of the event, as well as all drinks and snacks available during the entire weekend – 3 hours after the start of the main race).

Additional hospitality passes/packages can be ordered via FE Manager at the following rates:

- 25% discount between the fixed price per person per weekend

Inside the FE paddocks, the championship's sponsors enjoy the exclusive opportunity to make presentations in the form of stands; these presentations are confirmed by the FE Promoter in the

corresponding contracts. The special guidelines for hospitality must in any case be respected.

6. ADR

The obligatory ADR System as per Article 27.2 of the FIA Formula E Championship Sporting Regulations will be provided by the FE Organisation.

The fee for the 2014 season will be: €1,300 per car, for all events.

The ADR system may be used at events outside the FIA FE Championship.

The ADR system has to be returned to the FIA Technical Department no later than 15 days after the last test session of the FE season of the respective year.

7. MMM TELEMETRY

The obligatory MMM Telemetry system, as per article 27.3 of the FIA Formula E Championship Sporting Regulations, will be provided by the FE Organisation.

The fee for the 2014 season will be: €64,000 per team, for all events.

The MMM telemetry system may not be used at events outside the FIA FE Championship.

The MMM telemetry system must be returned to the FIA Technical Department no later than 15 days after the final test session of the FE season of the respective year.

8. WEBSITES

All FE Regulations, including their appendices, forms, team info's, FIA event visa, stewards' decisions etc., will be published on, and are available to be downloaded from, the official FE website www.fiaformulae.com under the link "Team info". <http://www.fiaformulae.com/teaminfo/>

Official digital notice board, Timing results, Live timing can be accessed through the following address: <http://fiaformulae.alkamelsystems.com/>

The digital technical passport can be accessed at the following address: TBA

9. FANBOOST

Fanboost will be allocated to the three drivers who received the greatest number of votes on the FEH app (90%) and on other social media (10%).

Voting will be open from 10 days before the event until 20 minutes before the start of the race.

The three drivers who will benefit from Fanboost will be noticed by the Chairman of the Panel of Stewards a maximum of 15 minutes before the race.

10. FORMS

The following forms can be requested from FEH for their dedicated purpose:

- Media Guide Registration Form for DRIVERS
- Media Guide Registration Form for TEAMS
- Paddock Logistic Form
- Application for private testing
- Confirmation of accidents

11. OFFICIAL ADVERTISING

Cars and drivers must comply at all times with the Team Support Package document provided by FEH except for specific derogations. This document is added to the sporting regulations as Appendix 4.

All advertising material (stickers and badges, except the competition numbers), will be provided by the FE Manager. In addition, no one may reproduce the stickers themselves or embroider the logos directly onto the overall.

The correct display of all stickers and badges will be checked at each official event. If the advertising instructions are not observed during the entirety of the events, including pre-event-, and pre- and mid-season testing, the respective team/driver will be reported to the stewards. All FE advertising partners have to be displayed as prescribed on all cars and all overalls throughout each public display. It must be ensured that none of the sponsor stickers are damaged in any way under any circumstances.

If no sticker or badge is handed out for one or more advertising spaces designated below, these areas must be reserved for the FE Promoter and must be kept free of any advertising, logos or special designs.

FE reserves the right to adapt the advertising spaces if necessary.

TEAM SUPPORT PACKAGE

Car livery and brand placement



Spark-Renault SRT_01E. Overall dimensions

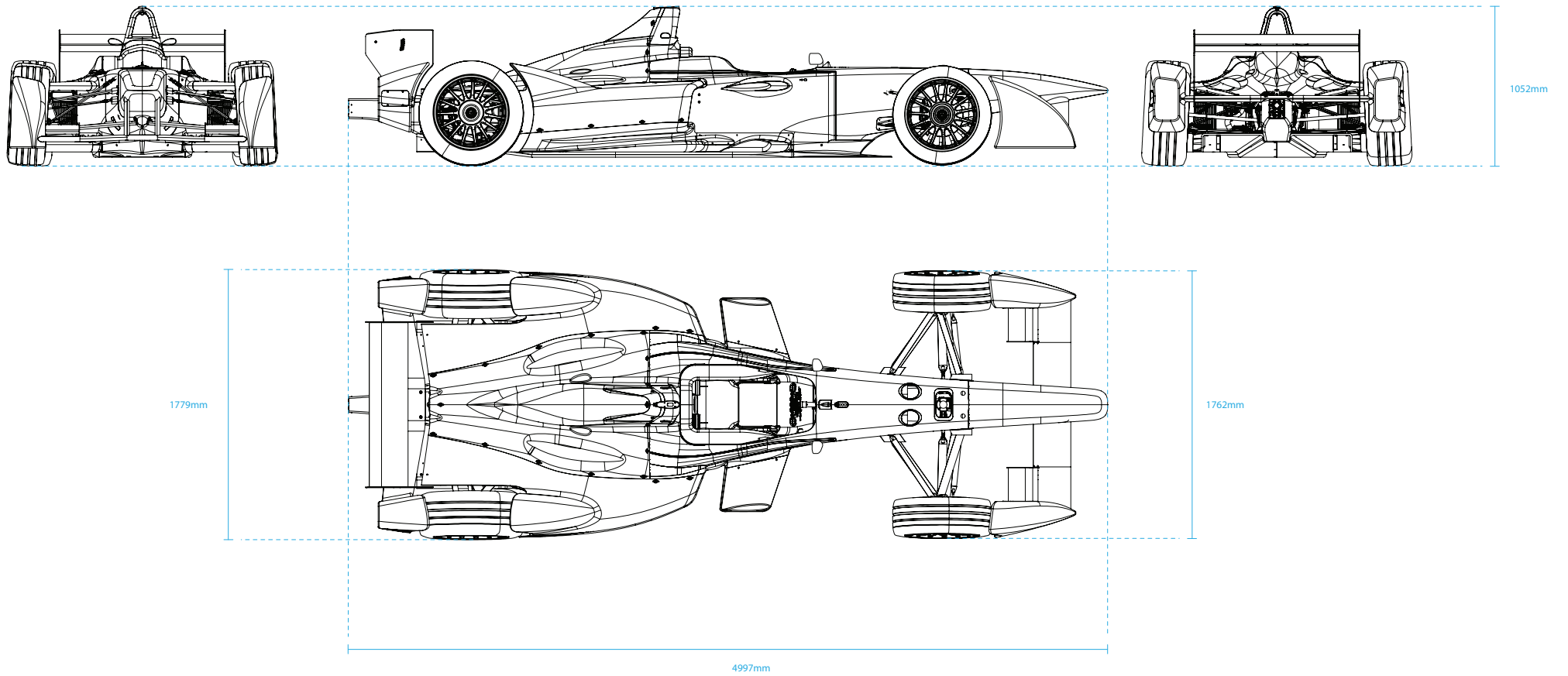

Spark-Renault SRT_01E. 3D view

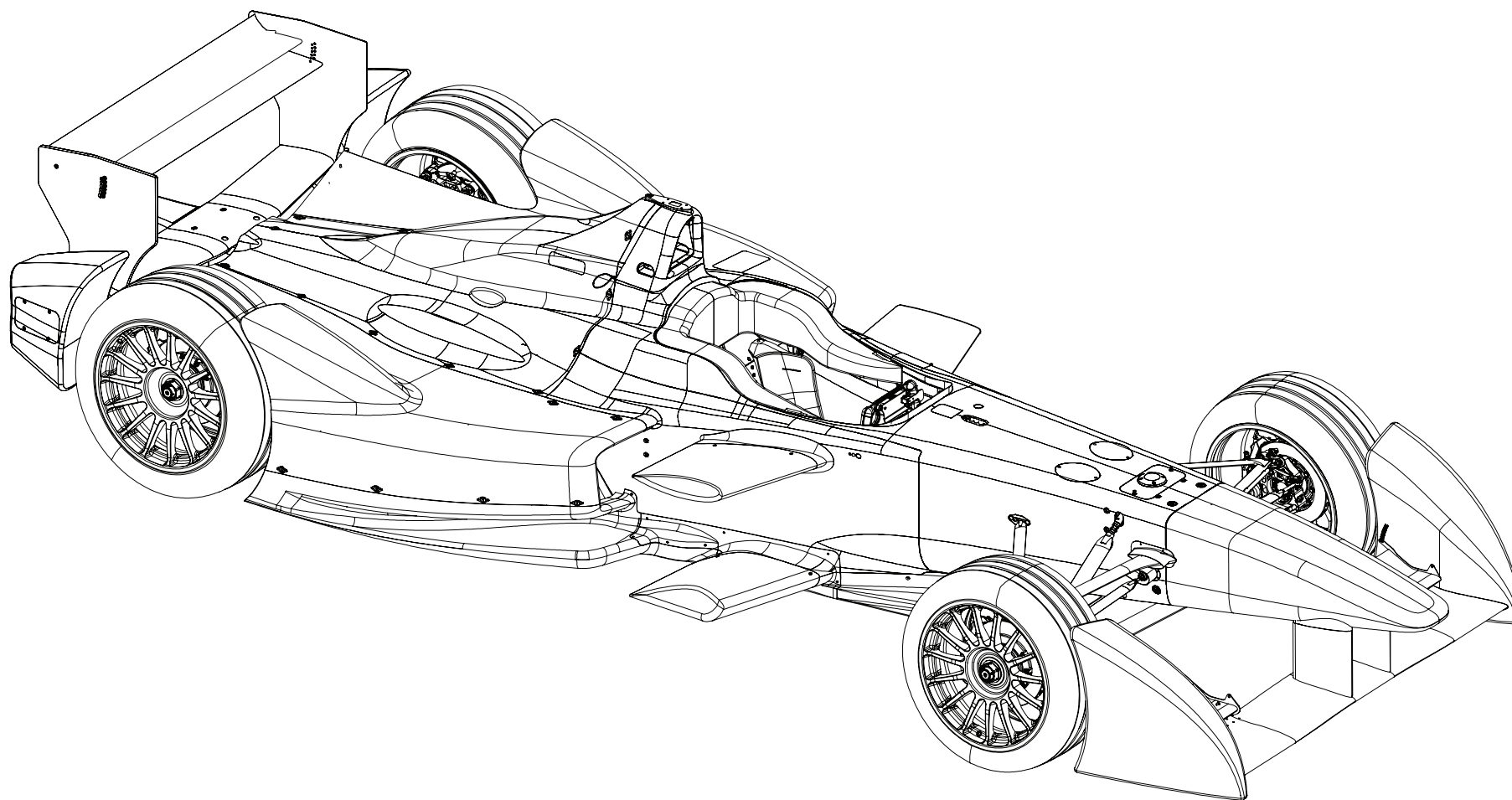

Spark-Renault SRT_01E. Car brand placement

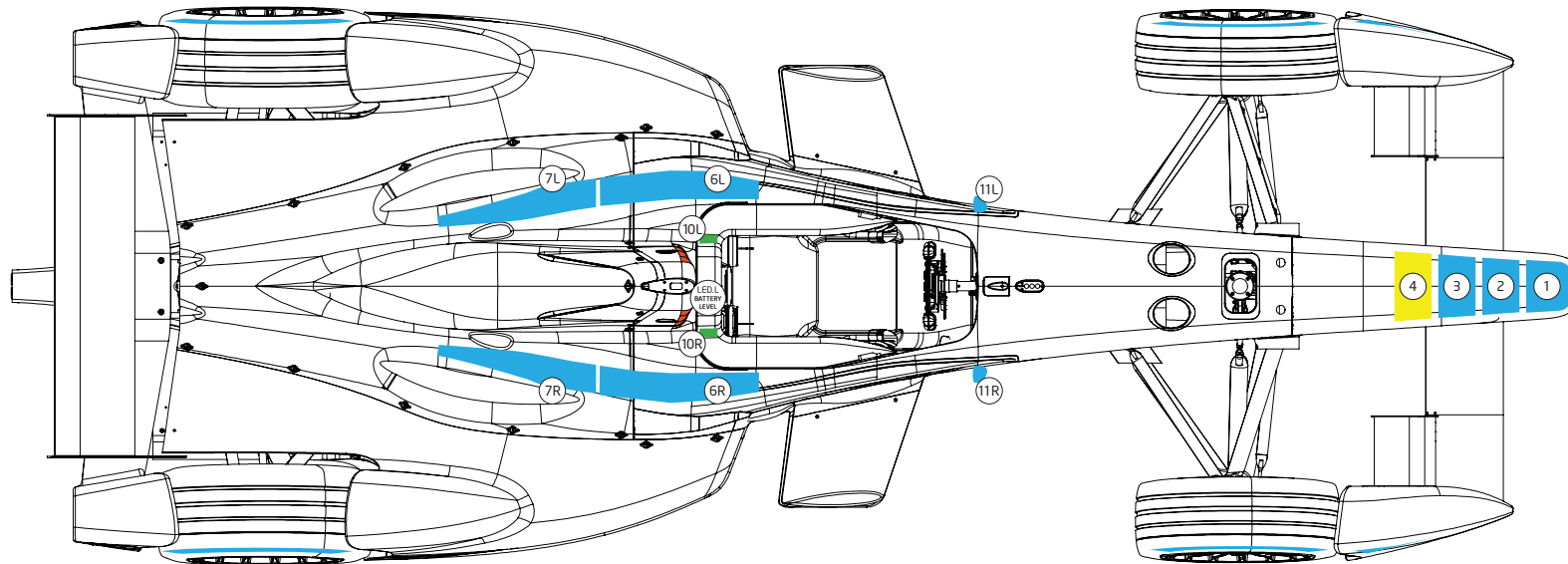
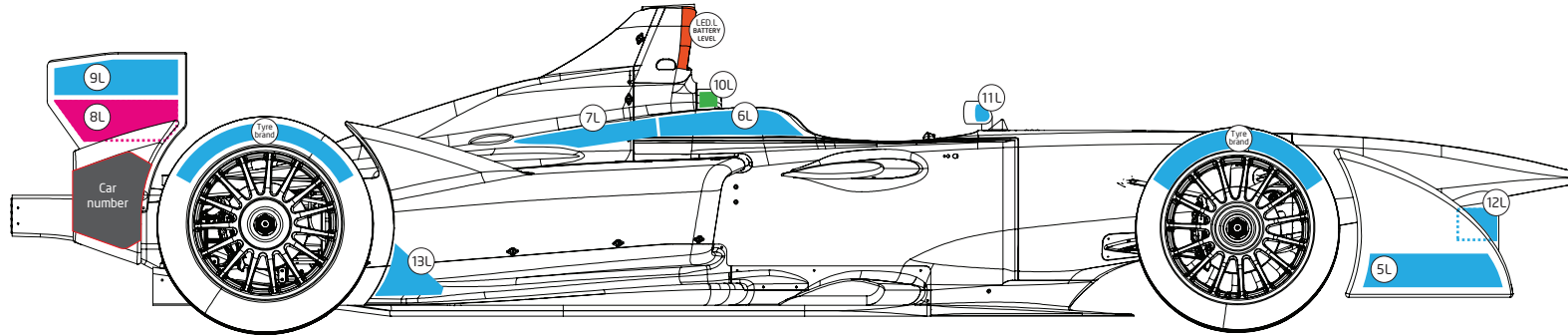

- FEH brand
- LED display
- Spark cars (Renault Logotype)
- FEH Reserved branding areas
- Space given back to teams
- FIA mandatory

Spark-Renault SRT_01E. Current branding (to be always included on visuals)

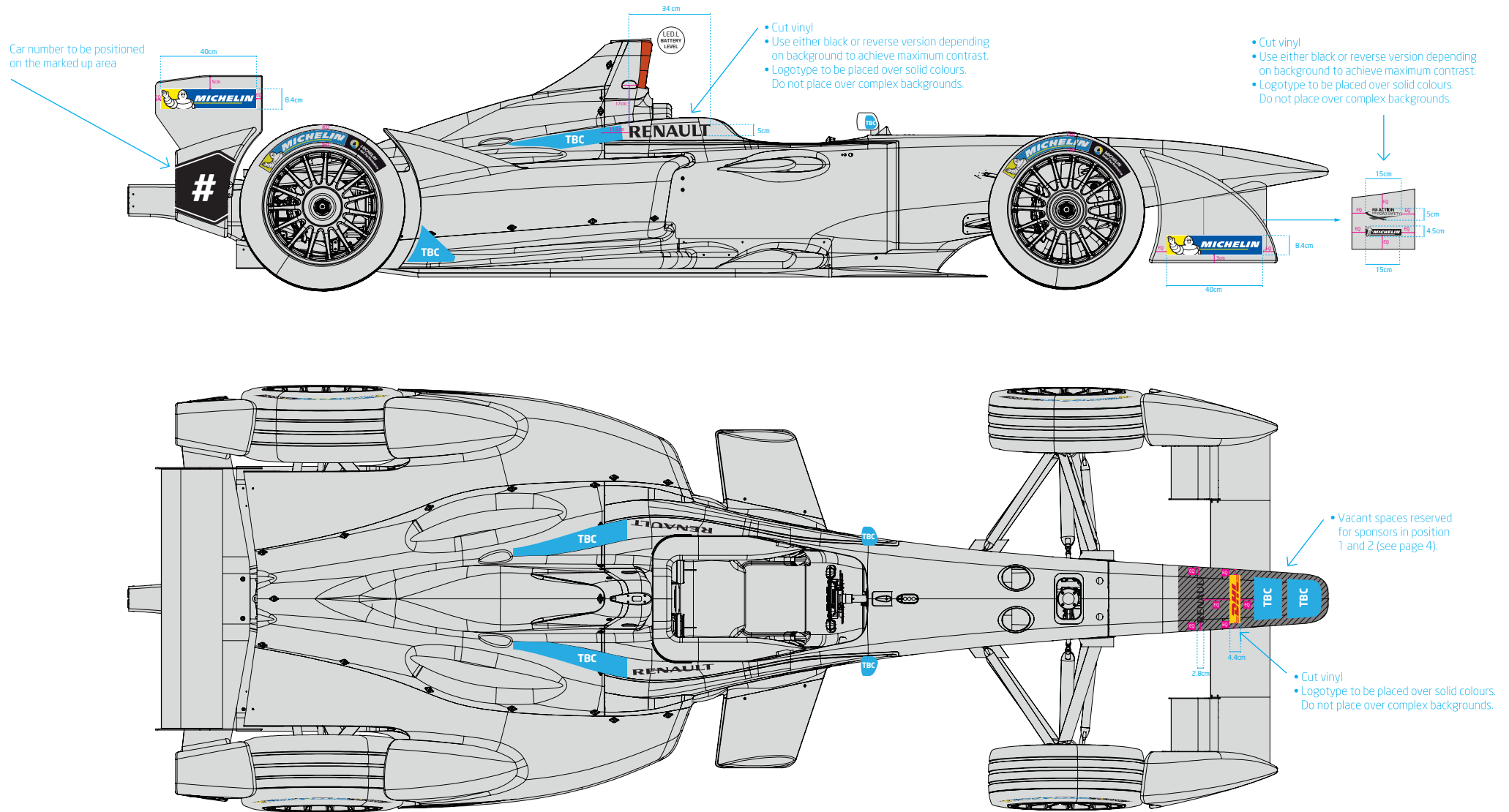

Note: All teams to feature Renault logotype except those deemed a manufacturer.

Spark-Renault SRT_01E. Logotype file index

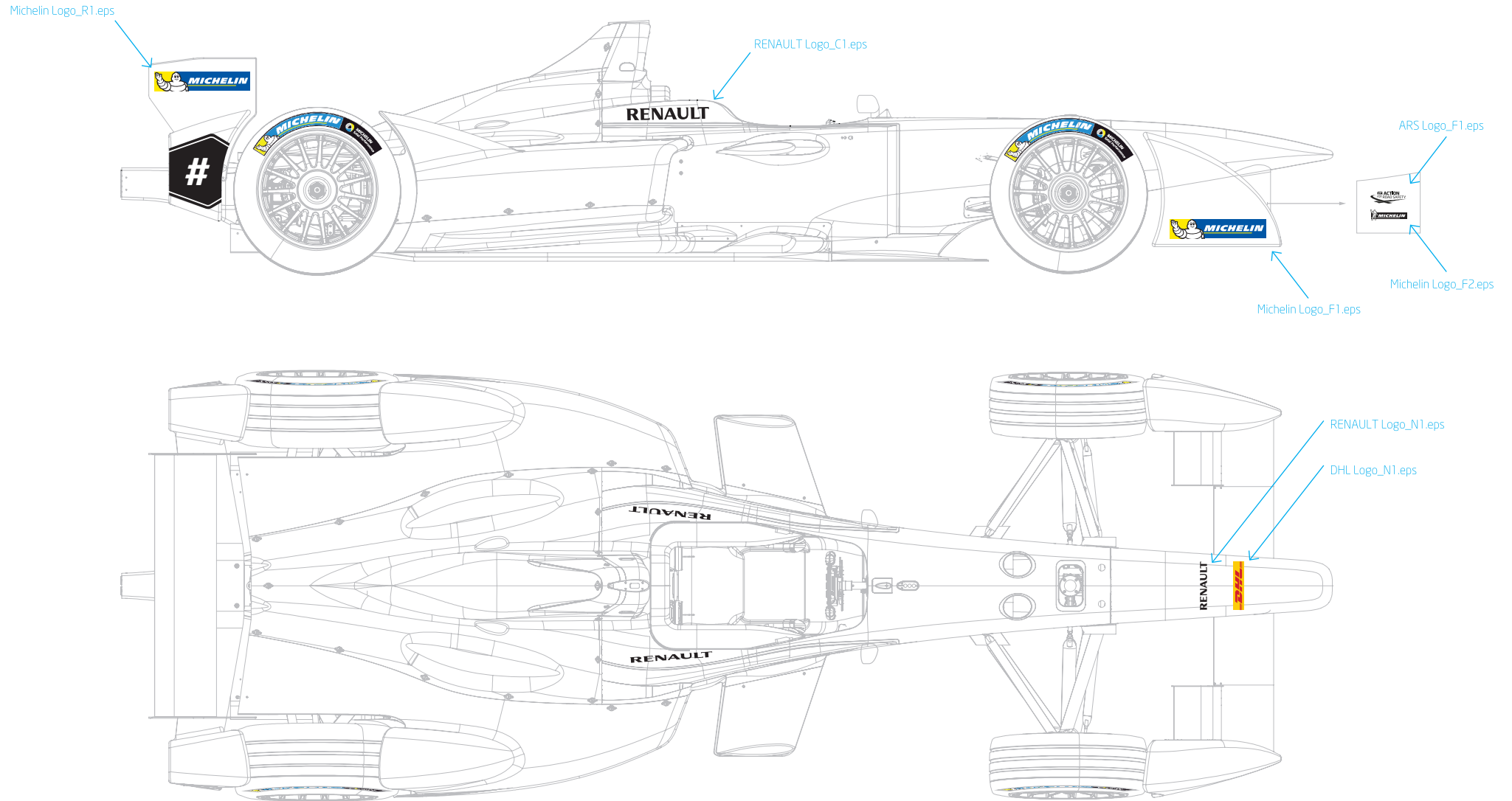

Note: All teams to feature Renault logotype except those deemed a manufacturer.

Spark-Renault SRT_01E. Car number standards

Car number example



Each car must carry the race number of its driver as published by the FIA. The race number must be visible on the rear wing side plates of the car in accordance with the requirements of the Organisation Rules.

A distinction must be made between the two cars. Race number colors will be imposed and will be different for the two cars available for each driver: for race number, font Neo Sans Bold Italic, 30 cm high and and stroke 25mm for race number backgrounds white and black.

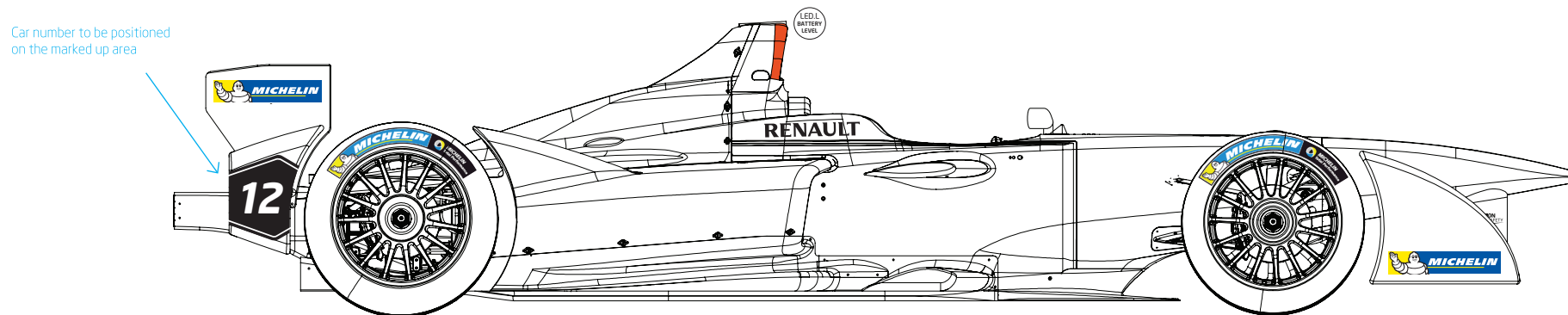

Driver's suit brand placement

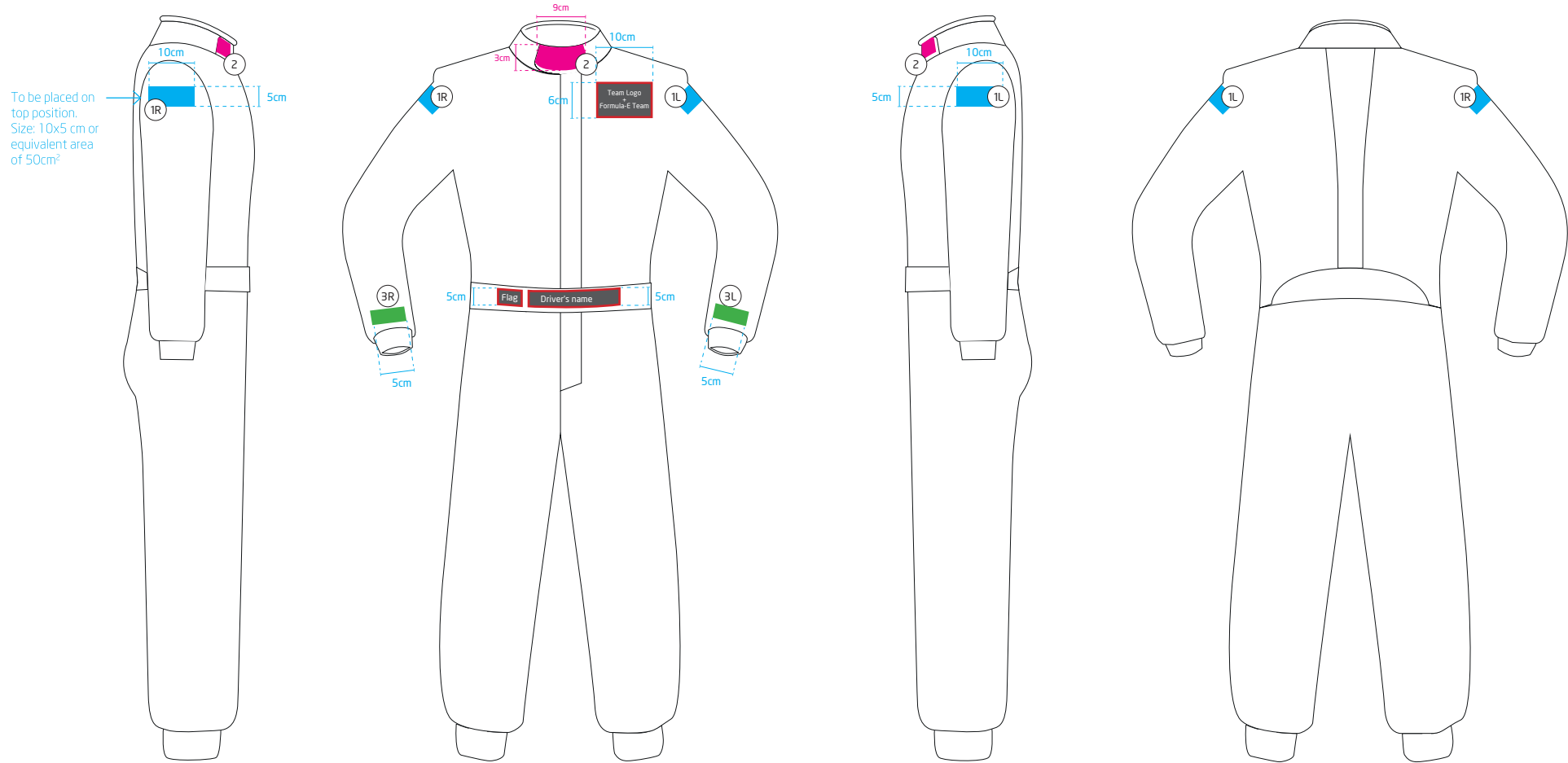

- FEH brand
- FEH Reserved branding areas
- Space given back to teams
- FIA mandatory

Driver's suit current branding (to be always included on visuals)

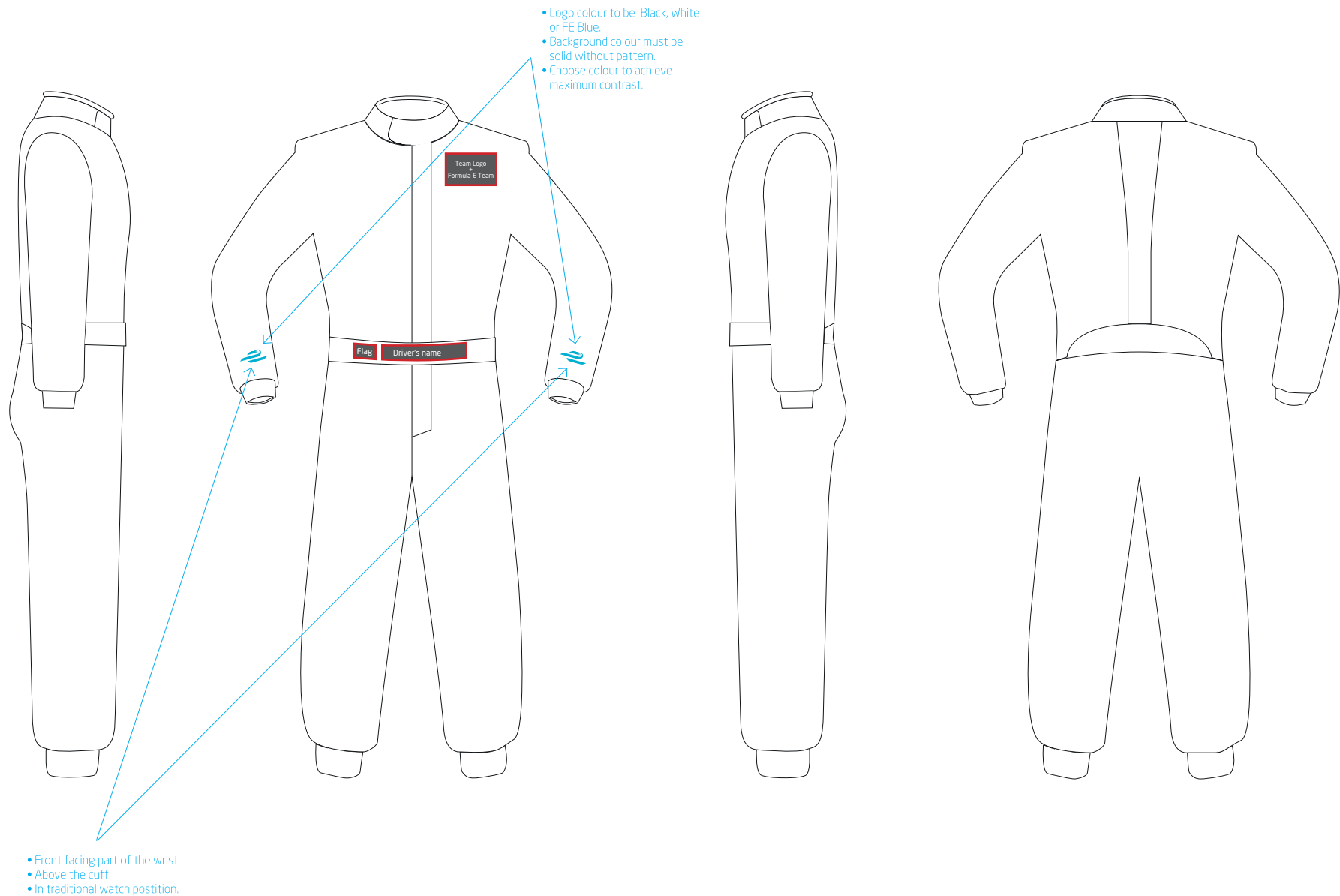

Helmet brand placement

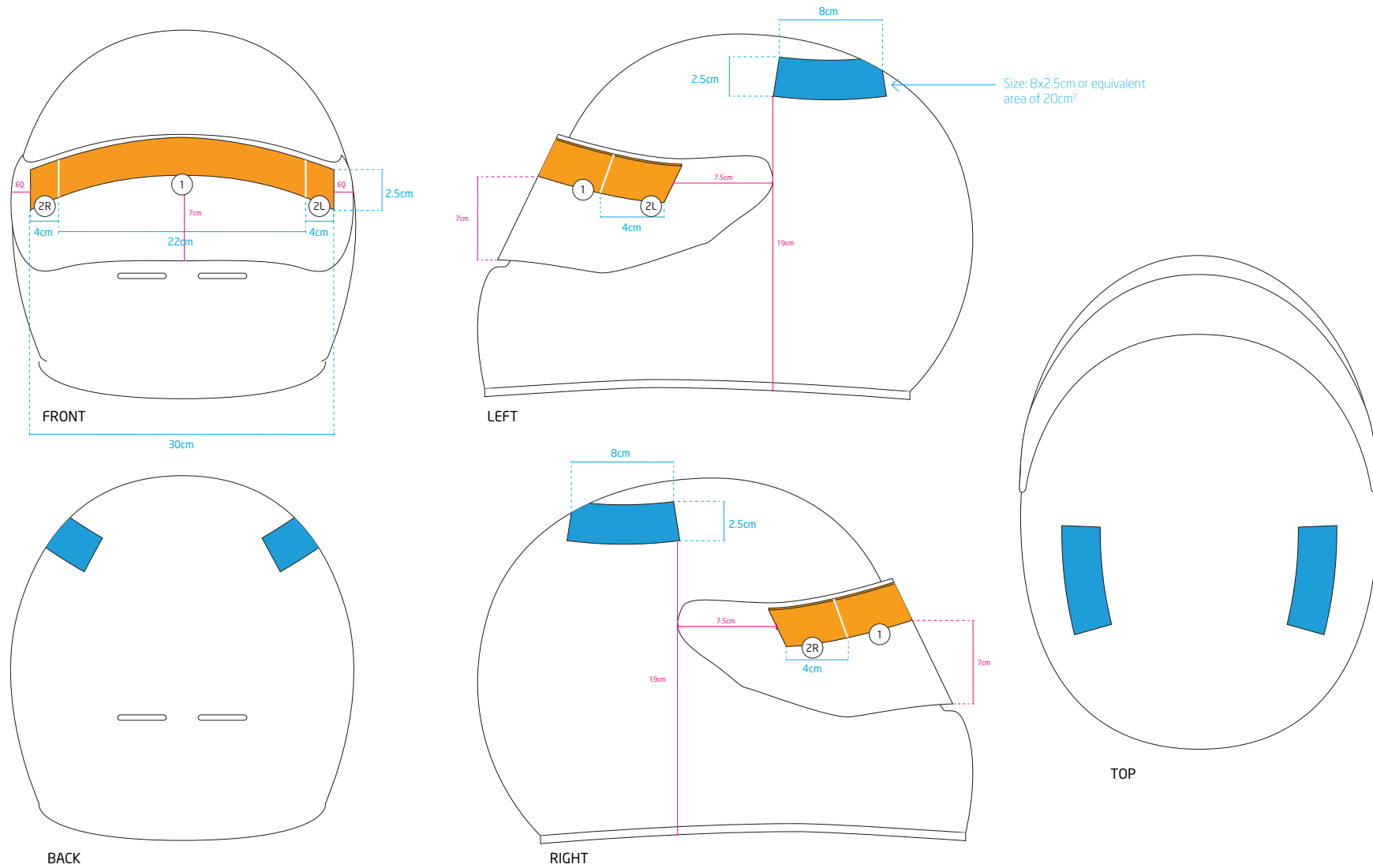

■ FEH Reserved branding areas
 ■ Space given back to teams

Helmet current branding (to be always included on visuals)

