



FEDERATION INTERNATIONALE DE L'AUTOMOBILE

**FIA STANDARD 3504-2019
LIGHT PANELS**

Version 2.0 – March 2020

FOREWORD

This standard prescribes the design requirements, test procedures and performance criteria for light panels intended for use by motor racing facilities to complement existing manual flag signalisation.

These light panels should increase the visibility and safety for signalling marshals through remote functionality, as well as enhancing the direct communication of regulatory requirements and notifications to competitors during FIA Championship competitions.

INDEX

1. GENERAL	5
1.1 HOMOLOGATION PROCEDURE.....	5
1.2 MANUFACTURER'S UNDERTAKING FOR THE STABILITY OF ITS PRODUCTS	5
2. SCOPE	5
3. DEFINITIONS	6
3.1 LUMINANCE (CD/M2)	6
3.2 REFERENCE AXIS.....	6
3.3 TEST AXIS	6
3.4 COLOUR COORDINATES	6
3.4.1 CIE 1931 standard colorimetric system.....	6
3.5 VIEWING ANGLES.....	6
3.6 LIGHT PANEL SYSTEM.....	6
3.6.1 Light panel.....	6
3.6.2 Marshal Control Device.....	7
3.7 MAIN SERVER.....	7
3.8 RACE CONTROL MANAGEMENT SOFTWARE PLATFORM.....	7
3.9 VARIABLE MESSAGE SIGN (VMS).....	7
3.10 FLASHING OPERATION.....	7
3.11 DUTY CYCLE	7
4. DESIGN AND FUNCTION REQUIREMENTS	8
4.1 GENERAL REQUIREMENTS	8
4.2 ELECTRICAL REQUIREMENTS	8
4.2.1 Power supply	8
4.3 MATERIAL REQUIREMENTS	8
4.4 ENVIRONMENTAL REQUIREMENTS.....	9
4.5 STRUCTURAL REQUIREMENTS	9
4.6 OPERATIONAL REQUIREMENTS.....	9
4.6.1 Local Operation	9
4.6.2 Marshal Control Device.....	9
4.6.3 Remote Operation	10
4.6.4 Race Control Management Software	10
4.7 MINIMUM DIMENSIONS REQUIREMENTS.....	10
4.8 WEIGHT	11
4.9 FRONT SCREEN.....	11
4.10 FRONTAL FRAME.....	11
4.11 VARIABLE MESSAGE SIGN (VMS).....	11

4.12	DATA COMMUNICATION PROTOCOL.....	11
5.	DESIGN AND FUNCTION ASSESSMENT	12
5.1	INSTALLATION GUIDELINES.....	12
5.2	MAINTENANCE GUIDELINES	12
6.	PERFORMANCE TESTS	13
6.1	TEST PARAMETERS	13
6.1.1	Test module.....	13
6.1.2	Test facility and apparatus	13
6.2	TEST MODULE PREPARATION.....	14
6.2.1	Stabilization phase.....	14
6.3	OPTICAL PERFORMANCE.....	15
6.3.1	Luminance	15
6.3.2	Uniformity of Luminance	15
6.3.3	Colour coordinates.....	16
6.3.4	Viewing angles.....	16
6.3.5	Colour shift	17
6.3.6	Visible Flicker.....	17
6.3.7	Sun phantom	17
7.	MARKING AND FIA LABELLING	19
7.1	MARKING.....	19
7.2	FIA HOLOGRAM	19

1. GENERAL

1.1 HOMOLOGATION PROCEDURE

Any manufacturer applying for homologation agrees to have understood this standard and the FIA Homologation Regulations for Circuit Equipment. A homologation application shall be submitted to the FIA and include a dossier. The dossier shall consist of the following:

- a) Homologation application template (file provided from the FIA upon request);
- b) Technical specifications;
- c) Installation guidelines;
- d) Repair and maintenance guidelines;
- e) Test report(s).

Light panels shall be tested by a test house approved by the FIA. The list of approved test houses will be available on the FIA website (www.fia.com).

The FIA will assign a homologation number and list all newly homologated light panels on the FIA website (www.fia.com) in accordance with the FIA Homologation Regulations for Circuit Equipment. The type and maximum number of extensions allowed must comply with the FIA Homologation Regulations for Circuit Equipment.

The FIA or any other FIA appointed body reserves the right to request post-homologation control tests in accordance with the FIA Homologation Regulations for Circuit Equipment.

The FIA also reserves the right to decline the homologation request should the application prove to be incomplete in accordance with the FIA Homologation Regulations for Circuit Equipment.

1.2 MANUFACTURER'S UNDERTAKING FOR THE STABILITY OF ITS PRODUCTS

When applying for the homologation, the manufacturer undertakes not to modify the design, materials and manufacturing process of the product. Extensions may be authorised at the discretion of the FIA in accordance with the FIA Homologation Regulations for Circuit Equipment.

2. SCOPE

This standard provides objective design and performance requirements for light panels intended for use in motor racing circuits. It addresses systems that are specifically designed for motorsport applications and that provide dual control, such as local stand-alone operation via the marshal control device and remote operation by the Race Control.

This standard defines different homologation Grades as follows:

- a) Grade 1 homologation will be for use in grade 1 circuits;
- b) Grade 2 homologation will be for use in grade 2 circuits;
- c) Grade 3 homologation will be for use in grades 3, 3E and 4 circuits.

The requirements per Grade 1, 2 and 3 presented herein will ensure that the light panels will have a minimum luminance within a certain range of vertical and horizontal angles as well as the required set of colour coordinates, to improve driver visibility across all the circuit grades. The standard also details the flag signals and their functions during race conditions.

This document is not intended to outline any existing details concerning the location and the number of light panels. It is assumed that the same principles to determine the marshal posts will form the basis for the location and the numbering of the light panel, in either a full circuit or partial circuit installation, and that adjustment in the location and the numbering of the light panels may be required to accommodate the type of racing.

3. DEFINITIONS

For the purposes of this standard, the following definitions apply:

3.1 LUMINANCE (CD/M²)

The intensity of light emitted from a surface per unit area in the reference axis direction. It carries information about the brightness of the displayed message.

3.2 REFERENCE AXIS

The axis originating on the reference centre of the test module being perpendicular to the frontal surface of the panel, unless otherwise specified by the manufacturer. In case it differs from the mechanical axis (maximum light intensity), the supplier could choose which axis to use for the performance tests.

3.3 TEST AXIS

The line from the reference centre of the test module to the luminance meter head.

3.4 COLOUR COORDINATES

The chromaticity of the colour is set in accordance with the CIE 1931 Standard Colorimetric Diagram unless stated otherwise.

3.4.1 CIE 1931 standard colorimetric system

A system for specifying the colour by determining the tristimulus values of the spectral power distribution of a coloured light.

3.5 VIEWING ANGLES

The horizontal viewing angle is the angle between the test axis and the vertical plane passing through the reference axis, and the vertical test angle is the angle between the test axis and the horizontal reference plane passing through the reference axis.

3.6 LIGHT PANEL SYSTEM

A light emitting object that is activated in conjunction with other elements to display the desired message. It comprises of the following parts:

- a) A certain number of light panels
- b) A marshal control device associated with each light panel
- c) A main server
- d) A race control management software

3.6.1 Light panel

Flat panel display, which comprises of a frontal and a rear graphic area, and may include the housing, the background-board and/or the front screen. It is activated in conjunction with other light panels to display the desired message.

- **Graphic area**

Flat surface containing an array of light-emitting diodes (LEDs) as pixels. When voltage is applied, pixel clusters are controlled and activated partly or fully, into forming the characters or pattern of the desired message.

- **Pixel**

Smallest element that contains LEDs and is capable of generating the full functionality of the graphic areas of a light panel.

- **Pixel pitch**

Distance between corresponding LEDs of adjacent pixels, both horizontally (H_{pitch}) and vertically (V_{pitch}).

- **Background-board**

Structure that surrounds the graphic area of the panel, to provide improved visibility by means of an increased contrast with the surrounding illuminance.

- **Front Screen**

A screen that protects the graphic area and all its parts against dust and water.

3.6.2 Marshal Control Device

Hand-held, water resistant controller, used to execute or change a display message by the local marshal control.

3.7 MAIN SERVER

Central unit that manages the input signals received from either a Marshal Control Device or the Race Control and elaborates them into power commands, to execute the desired message.

3.8 RACE CONTROL MANAGEMENT SOFTWARE PLATFORM

Software used to manage and control all the connected light panels remotely and synchronously.

3.9 VARIABLE MESSAGE SIGN (VMS)

Electronic signs used to transmit information to drivers, marshals and track personnel, which may consist of flag coloured signals, and/or symbols and/or text.

3.10 FLASHING OPERATION

Mode of operation in which the light is switched on and off with a fixed period and duty cycle.

3.11 DUTY CYCLE

Fraction of one period in which the light is on during the flashing operation.

4. DESIGN AND FUNCTION REQUIREMENTS

The design of the light panel system shall comply with the requirements laid out in this chapter. The FIA reserves the right to refuse the homologation if the design or function is deemed unacceptable by the FIA Circuits Commission.

4.1 GENERAL REQUIREMENTS

Light panels shall be based on light-emitting diodes (LED) technology. Each light panel shall have two graphic areas, one on the front and one on the rear side of the panel. The rear area can have different patterns and dimensions of those required for the frontal area, as detailed in 4.7 MINIMUM DIMENSIONS REQUIREMENTS of this standard. Each light panel should be able to be controlled either remotely from Race Control or manually from the individual signalling marshal at the track. It should be provided with a system that provides field-adjustable luminance intensity (dimming), to adapt to the background ambient light level in which race events are held. Due to extreme operating conditions, they should be provided with means of protection against thermal overload.

4.2 ELECTRICAL REQUIREMENTS

The light panel system shall conform to ISO electrical safety requirements and low voltage Directives for maximum safety, in compliance with local regulations. Circuits and connectors must be located out of reach of the public, and designed so that exposure to live electrical equipment will not occur in case of the accidental detachment of exposed elements of the system.

4.2.1 Power supply

The connection of the light panel system to the power supply shall be in accordance with the manufacturer's guidelines. In the event of short voltage interruptions in the supply of specific duration, light panels shall operate as follows:

- a) For interruptions of duration less than 50 ms, there should be no visible effect
- b) For interruptions of duration less than 100 ms, the panels shall continue displaying the current message

4.3 MATERIAL REQUIREMENTS

Materials used for the hardware of the light panels shall be resistant to corrosion. The FIA reserves the right to request manufacturers to carry out testing on the material, to demonstrate the durability of the material by reference to the relevant European Standard EN 12899-1:2001, or similar European technical assessment. Additionally, all equipment, cables and controls shall be made out of materials that will not induce fire or any risks in case of an accident.

4.4 ENVIRONMENTAL REQUIREMENTS

All equipment must be designed to operate under the following requirements:

- a) The minimum degree of protection against ingress of dust and water provided shall be IP 65 without external casing and IP 55 with external casing, when tested in accordance with BS EN 60529:1992.
- b) Temperature: -20 to +60°C
- c) Relative humidity: 30% RH to 95% RH

The manufacturer shall provide a declaration to the FIA, by which it certifies that the system is capable of exposure to such environmental conditions without suffering any permanent damage. The FIA reserves the right to undergo testing in accordance with the relevant European Standards to check the compliance with these requirements, and to refuse the homologation if the results are deemed unacceptable.

Equipment performance should not degrade or deviate significantly from the homologation test results when operated at the typical ambient temperature extremes seen at the intended installation site.

4.5 STRUCTURAL REQUIREMENTS

All equipment must be designed in order to operate safely under normal conditions by the marshals and other track personnel. The equipment must remain safe after damage by an accident to allow operational safety. Reliability of all equipment, cables and controls shall be guaranteed for a minimum of approximately 5 years extensive usage.

4.6 OPERATIONAL REQUIREMENTS

Each light panel should be able to be locally operated by the signalling marshals on the side of the track and remotely controlled from the Race Control.

4.6.1 Local Operation

Light panels shall be locally operated by the signalling marshals via the corresponding marshal control devices, either in direct proximity of the panel or at a nearby location. For system design purposes it should be possible to operate the panel within a distance of up to 250m.

4.6.2 Marshal Control Device

The marshal control device should be designed so as to be as compact and light as possible, to be easily operable and transportable, and provide an intuitive user interface. It should avoid the possibility of accidental operations. The control device must be rechargeable and able to be operated while being recharged. It can be either button-based or touched-based. It shall be easy to operate with appropriate gloves and could be equipped with LED light indicators, to display different modes of operation of the unit, as well as an informational display. The display should give information about the status of the device, the corresponding panel and incorporate repeater lights, to show the status of the light panels at the neighbouring marshal posts upstream and downstream.

4.6.3 Remote Operation

The information displayed on the light panels should always be relayed directly to the Race Control, who should always have the capability of operating them remotely. Flag signals reserved for the Race Director and the Clerk of the Course must be solely operable by the Race Control.

4.6.4 Race Control Management Software

The race control program should give Race Control the complete control of all the light panels around the track, to allow real-time monitoring of the flags' status and diagnose the main system parameters. In particular, the minimum set of features the Race Control program should include is, but is not limited to:

- a) Track map displaying all the light panels and their locations on the track
- b) Monitoring of the operating power supply
- c) Monitoring and control of all light panels' status, i.e. which flag type and which light marshal is active on the track
- d) Monitoring of working temperature, and cooling system activation
- e) Display of any malfunctions, such as short circuit, thermal overheating for each individual light panel, LEDs integrity, communication errors
- f) Logs systems stored in the internal memory of the battery, which registers all the operations accomplished as well as the flag incidents on the track, including detailed information on the flag type, the activation point, date and time of the incident
- g) Systems check and communications check with all equipment constituting the system;
- h) Option for online servicing and upgrading

Any command locally executed by a marshal via a marshal control device should be able to be overruled by the main Race Control.

4.7 MINIMUM DIMENSIONS REQUIREMENTS

The minimum required dimensions of the light emitting frontal and rear graphic area of each light panel in direction of the reference axis should be as detailed in the Table 1 below. The aspect ratio of panel shall be 3:2 up to 1:1.

Each panel shall be designed such that the whole of the front and rear graphic areas, shall be fully and uniformly populated with pixels.

Table 1. Frontal/Rear Panel Minimum Dimensions

Grades	(Light emitting) Graphic Area (Frontal)	(Light emitting) Graphic Area (Rear)
Grade 1 Light Panels	4500 cm ²	360 cm ²
Grade 2 Light Panels	1890 cm ²	360 cm ²
Grade 3 Light Panels	1890 cm ²	360 cm ²

4.8 WEIGHT

A maximum of 50 kg is mandatory for any grade of light panel. This does not include cables, brackets or optional equipment such as controllers.

4.9 FRONT SCREEN

When the light units are provided with additional front screen, the latter should be securely fitted to the external panel housing. It should be made from UV and scratch resistant materials and be easily removable to facilitate maintenance.

Manufacturers should detail the measures they have taken to prevent condensation from forming on the front screen. If no frontal screen is used. In case there is a frontal screen, this is recommended to have a certain inclination with respect to the vertical axis of the light panel. This is done to prevent reflections from the sun light.

4.10 FRONTAL FRAME

When frontal frame is used, the front contour of the board is matt black or dark coloured, to improve the overall contrast with the surrounding illumination and increase the perception of the information displayed.

4.11 VARIABLE MESSAGE SIGN (VMS)

The information displayed on the panels should be to supplement traditional circuit flags during racing, and shall consist of static or waved coloured signals, with the appropriate brightness level and colour coordinates.

Display in form of symbol or text must be such that the text is abbreviated in English and the height of each character is at least half of the height of the frontal and rear graphic area. It is required that the message can be easily customized for the specific needs and different ways of operation, to accommodate the type of racing event or other FIA Championship requirements. The minimum level and basic functions of static and waved flag signals shall be defined using the specifications detailed in the Appendix 2 of this standard.

4.12 DATA COMMUNICATION PROTOCOL

Light panels should be networked with each other and the corresponding marshal control devices, and maintain a two-way communications with the Race Control, via a redundant fibre-optic ring network or a wireless radio communication link.

5. DESIGN AND FUNCTION ASSESSMENT

The light panel system shall be designed such that its integrity is not compromised during its entire service life. Clear and comprehensive guidelines are required to operate the system under normal conditions correctly. The FIA reserves the right to refuse the homologation if the installation and maintenance procedures are deemed unacceptable.

5.1 INSTALLATION GUIDELINES

When applying for the homologation, the manufacturer must provide installation guidelines of the light panel system to the FIA as part of the homologation application dossier.

These guidelines shall include detailed information to enable the correct installation. The manufacturer undertakes not to modify the fundamental installation procedure included in the guidelines. Variations must be authorised by the FIA. The FIA reserves the right to refuse the homologation if the installation procedure is considered unacceptable.

5.2 MAINTENANCE GUIDELINES

When applying for the homologation, the manufacturer must provide maintenance guidelines of the light panel system to the FIA as part of the homologation application dossier, to ensure that any damage does not reduce the efficiency of the system. This shall include details of routine maintenance recommendations of spare parts and details of estimated lifetime of components. For permanently installed systems, all maintenance activities shall be easy to be carried out and ensure maintained performance, as outlined in 6 PERFORMANCE TESTS of this standard. The manufacturer shall also offer a maintenance service if required.

6. PERFORMANCE TESTS

The performance requirements presented herein are mandatory for light panel systems. The FIA reserves the right to request further tests if new technology is presented for homologation.

6.1 TEST PARAMETERS

The test module and the test facility shall comply with the requirements set out below.

6.1.1 Test module

The test module shall be complete with all the hardware components of a light panel, but also cables, controllers and/or data transmission/reception equipment that are fitted in a production unit, to enable performance testing. The test module shall be selected at random from the production and shall be fully representative of the final product. For the purpose of testing and due to limitations of the currently used test apparatus, the manufacturer is required to inform the FIA and the test laboratory in advance about the overall size and weight of the panel.

If a final prototype is made available for testing, the manufacturer is required to declare and confirm that the characteristics of the final product do not differ from those of the test module considered for the performance testing. The manufacturer commits to obtaining the FIA's approval before any substantial modification to the tested and approved product is carried out. The FIA reserves the right to refuse the request if the final prototype is deemed unacceptable for the purpose of the homologation testing.

6.1.2 Test facility and apparatus

All the performance testing specified herein shall be performed in a temperature-controlled darkroom, whose conditions during testing shall be consistent with Table 3. below.

Table 3. Test facility requirements

Condition	Requirement	Remark
Dark-room illuminance	< 2 lux*	Near the panel
Room Temperature	23 C ± 4 C	Near the panel
Relative humidity	10% to 85 %	-

**A lower value is used for colour measurements.*

During testing, it is important to eliminate any stray lights. If parts of the equipment used for controlling the test module under test affect the surrounding illuminance, then those parts should be adequately covered.

A calibrated photometric laboratory with light intensity measurement instrumentation is required for the execution of the performance tests.

6.2 TEST MODULE PREPARATION

The test module should be securely mounted onto a measuring rotating table. Care should be taken to ensure it is securely fixed and the optical orientation of the frontal surface in relation to the measuring device is correct. This is important to assure that the assessment will be done at the required inclinations of the graphic area of the panel, and for good repeatability of the test results. If required for reasons of geometrical or physical constraints of the panel, any alternative mounting outside of normal conditions shall be approved by the FIA prior to testing.

The working distance between the front lens of the measuring device and the frontal graphic area of the test module over which the meter can focus shall be minimum 10 meters.

Before commencing the performance tests, the following checks shall be undertaken:

- a) Switch ON the test module in white, non-flashing mode, and check that there is no partial, incomplete or false display;
- b) Set the voltage to the specified operating voltage of the light panel, and check that there is no partial, incomplete or false display;
- c) Record the specified operating voltage of the test module, which should correspond to the normal user conditions for power supply. If the operating voltage is known to vary in practice, either because of fluctuations of the electricity supply during operation or because the signal is operated at different voltages depending on ambient conditions, measurements shall be made at the lowest and highest likely operating voltage in addition to measurements made at the specified operating voltage.

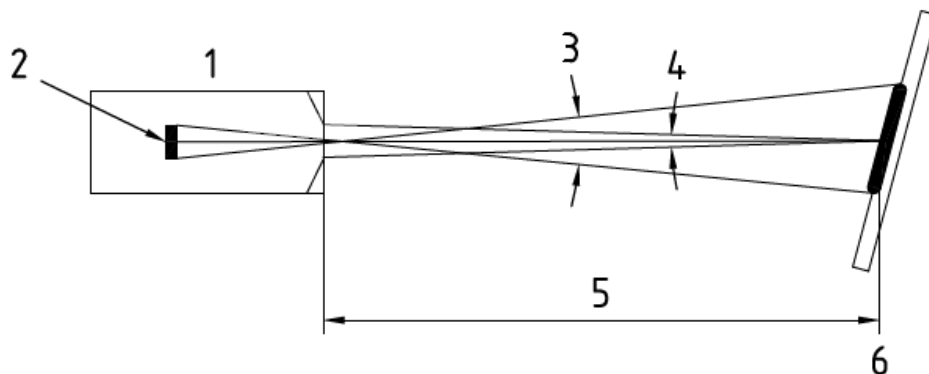

Key

- | | |
|---|-------------------------|
| 1 | Luminance meter |
| 2 | Photo-sensitive element |
| 3 | Field of View (FOV) |
| 4 | Acceptance cone |
| 5 | Working distance |
| 6 | Test module |

6.2.1 Stabilization phase

The test module shall display the white flag at its maximum brightness, and have been in operation for sufficient time to be stabilised before making any performance measurement. The resulting light on the test module is considered stable when its output luminance, measured in cd/m^2 , does not change more than $\pm 3\%$ over a warm-up period of 30 minutes. Similarly, the chromaticity coordinates shall be recorder throughout the warm-up period of 30 minutes at 2 minutes intervals, to assure they lay within the specifications defined in 6.3.3 Colour coordinates of this standard. Drop peaks in the luminance measurements at the beginning of the test will not be taken into consideration.

6.3 OPTICAL PERFORMANCE

All the performance measurements presented herein shall be performed for the individual flag signal colour, such as White, Yellow, Red, Blue and Green. The test procedures are grouped and shall be conducted in the sequence laid out below for each of these individual flag signal colours.

The test environmental conditions are specified in 6.1.2 Test facility and apparatus of this standard. The measurements shall be made at the specified operating voltages of the light panel, or in accordance with the manufacturer's instructions as per 6.2 TEST MODULE PREPARATION of this standard.

6.3.1 Luminance

Luminance gives an indication of the overall perception that result from light reaching the driver's eye. The resulting brightness takes into consideration the measurable luminance of the surface of the light panel, plus any conditions of observation that may affect the perception. Luminance measurements are applicable to the following flag signal colours: white, yellow, red, blue and green.

- **Test conditions**

The measurement configuration shall be arranged so as to have the luminance meter perfectly aligned with the reference centre of the test module, perpendicular to the reference axis. The test will be conducted as follows:

- a) Luminance measurements shall be made with the test module powered to the specified operating voltage, or in accordance with the manufacturer's.
- b) One luminance reading shall be taken per each of the individual flag signal colours in direction of the reference axis, and the corresponding value shall be recorded and expressed in candela per square metre (cd/m^2).

- **Performance criteria**

When the test module is tested in accordance with this standard:

- a) For Grade 1 homologation, the minimum on-axis luminance shall be 60,000 cd/m^2 for yellow flag signal and 37,000 cd/m^2 for red flag signals.
- b) For Grade 2 homologation, the minimum on-axis luminance shall be 33,000 cd/m^2 for yellow flag signal and 16,000 cd/m^2 for red flag signals.
- c) For Grade 3 homologation, the minimum on-axis luminance shall be 10,000 cd/m^2 for yellow flag signal and 8,000 cd/m^2 for red flag signals.

6.3.2 Uniformity of Luminance

The test module shall appear uniformly bright over its entire frontal graphic area and shall have no abrupt changes of luminance. Luminance uniformity measurements shall be done in accordance with this standard and shall be applicable to the following flag signal colours: white, yellow, red, blue and green.

- **Test conditions**

To measure the luminance uniformity, the frontal graphic area of the test module shall be virtually divided into $3 \times 3 = 9$ test areas and the luminance reading shall be taken and averaged over each of these areas. The corresponding values shall be recorded and expressed in candela per square metre (cd/m^2).

- **Performance criteria**

When the light panel is tested, the ratio of the greatest and the least luminance readings (cd/m^2) measured from each of these regions shall not deviate more than 20%.

6.3.3 Colour coordinates

Colour coordinates specify the allowable colours for steady signal lights and flashing signal lights.

- **Test Procedure**

The spectral power distribution of the light emitted by a signal light should be measured using a spectroradiometer and the 1931 CIE chromaticity coordinates (x,y) shall be calculated using the methods and tables outlined in the European Standard CIE S004 Colours of Light Signals. Alternative methods may be used, provided it has been validated by reference to the spectroradiometric method and approved by the FIA prior to testing.

- **Performance criteria**

When the light panel is tested in accordance with this standard, the colours of light signals shall have chromaticity coordinates (x,y) that lie inside the following areas:

- Red Light Signal Colour: Class A1**
Red light signal colours shall lie within the chromaticity area ABCD of the CIE 1931 standard colorimetric system, as detailed in the Appendix 1 of this standard. It includes persons in the user group with defective colour vision.
- White Light Signal Colour: Class A**
White light signal colours shall lie within the chromaticity area IJKL of the CIE 1931 standard colorimetric system, as detailed in the Appendix 1 of this standard. Given the fact that the colour of a white signal shifts toward orange-yellow when viewed from longer distances, this class help to distinguish from yellow light signal colours.
- Green light signal colour: Class A**
Green light signal colours shall lie within the chromaticity area MNOP of the CIE 1931 standard colorimetric system, as detailed in the Appendix 1 of this standard. It includes persons in the user group with defective colour vision.
- Blue Light Signal Colour: Class A**
White light signal colours shall lie within the chromaticity area QRST of the CIE 1931 standard colorimetric system, as detailed in the Appendix 1 of this standard. It includes persons in the user group with defective colour vision.
- Yellow Light Signal Colour: Class FIA 1**
Yellow light signal colours shall lie within the chromaticity of the "Selective Yellow" region of the UNECE R48 standard, detailed as well in Appendix 1 of this standard.
- Orange Light Signal Colour:**
Orange light signal colour shall lie within the chromaticity of the area EFGH of the CIE 1931 standard colorimetric system, as detailed in the Appendix 1 of this standard.

Detailed information concerning the boundaries of the recommended chromaticity areas is detailed in the Appendix 1 of this standard.

6.3.4 Viewing angles

The viewing angles of a light panel are measured both horizontally and vertically, and indicate on what range and with which luminance the information displayed on the graphic area of the panel is visible in relation to the reference axis of the frontal graphic area of the test module. This is considered of great importance to assure correct perception of the information displayed.

- **Test conditions**

Tests will be conducted as follows:

- a) One luminance reading shall be taken per each of the individual colours at 5 degrees intervals to the right and left of the reference axis and the corresponding values shall be recorded and expressed in candela per square metre (cd/m²).
- b) One luminance reading shall be taken per each of the individual colours at 5 degrees intervals above and below of the reference axis and the corresponding values shall be recorded and expressed in candela per square metre (cd/m²).

- **Performance criteria**

The required distribution of luminance should be as follows:

- a) The intensity within 40° to the right and left of the reference axis shall be above 50% of the minimum intensity required for that specific Light Panel grade.
- b) The intensity within 15° below and above of the reference axis shall be above 50% of the minimum intensity required for that specific Light Panel grade.

No drastic luminance drop should occur in angles over the indicated above, $\pm 40^\circ$ and $\pm 15^\circ$ respectively.

6.3.5 Colour shift

During the previous tests, not only the luminance of the Light Panels gets affected, but also the colour perception to the human eye. Although an exclusive performance test is not done regarding this matter, the colour coordinates should be within the chromaticity areas indicated in 6.3.3 Colour coordinates, when the different tests are performed.

- **Performance criteria**

During the different tests, at least 90% of the evaluated points should be within the specified colour regions.

6.3.6 Visible Flicker

Light Flicker is a physical phenomenon which cause changes in the brightness of a light source. Although this can happen due to numerous facts, the performed test will be based on the fluctuations of the power supply voltage.

According to the International Commission on Illumination, flicker can be defined as the “impression of unsteadiness of visual perception induced by a light stimulus whose luminance or spectral distribution fluctuates with time” (CIE, 2011, term 17-443),

- **Performance criteria**

Minimum flickering frequency should be over 200 Hz. A higher number could be requested in case the symbols, signs and flags are not seen correctly by the racing drivers or by the TV cameras.

6.3.7 Sun phantom

Sun phantom is a false light signal caused by reflection of radiation from sun illuminance by the graphic area of the test module. The sun phantom effect makes a light panel appear to be switched ON when in fact it is OFF, thus confusing the driver.

- **Test conditions**

Tests will be conducted as follows:

- a) The frontal surface of the test module shall be illuminated by a projector simulating direct sunlight. The reference axis of the test module and the optical axis of the projector shall form an angle of 10° below the reference axis. The opening angle of the projector emitting surface seen from the front surface of the roundel (angle α) shall be smaller than 1°, while the opening angle of the photometer seen from the front surface of the roundel shall be smaller than 3°. The distance between the front surface and the photometer lying on the reference axis of the roundel shall be 10 m.
- b) The luminance of the test module should be measured along the reference axis when the test module is switched on and the projector is switched off $\rightarrow L_{\text{signal}}$.
- c) The luminance of the test module should be measured along the reference axis when the test module is switched off and the projector is switched on $\rightarrow L_{\text{phant,10klx}}$. The projector should produce an illumination in the plane of the front surface of 10,000 lx. If the effective illuminance

($E_{t,eff}$) in the plane of the front surface is not 10,000 lx, then $L_{phant,10klx}$ can be calculated from the measured $L_{phant,eff}$ as specified in the European Standard CIE S006.1/E.

- **Performance criteria**

The phantom light luminance ratio $L_{signal} / L_{phant,10klx}$ of the intensity of the real to false signals shall be at least 15 to 1.

7. MARKING AND FIA LABELLING

A light unit approved by the FIA according to this standard shall be properly marked and bear an FIA hologram, in accordance with the instructions given below.

7.1 MARKING

The product marking shall include at least the following information:

1. FIA Standard Number
2. Manufacturer's name, which may be replaced by its logo
3. Serial number (unique serial number per product)
4. Model Name
5. Homologation number assigned by the FIA

Whenever possible, the marking shall be at the back of the housing. The exact positioning of the markings, their size and colour will be decided on a case-by-case basis depending on the panel layout at the discretion of the FIA.

7.2 FIA HOLOGRAM

It is recommended that the FIA Hologram be placed at the back of the housing, to be easily visible and/or accessible. The FIA reserves the right to define the exact positioning depending on the panel layout. The FIA hologram shall not be available outside the manufacturer's premises and maintenance may only be carried out by the manufacturer or their official representative.

The FIA hologram will be controlled by the FIA, which reserves the right for its officials or the officials of an ASN to remove or strike out the label. The FIA hologram must be purchased from the FIA.

APPENDIX 1. CHROMATICITY COORDINATES

Coordinates of intersection points of allowed chromaticity area boundaries

COLOUR	CHROMATICITY COORDINATES				
RED LIGHT CLASS A1*	x	A 0,66	B 0,68	C 0,71	D 0,69
	y	0,32	0,32	0,29	0,29
WHITE LIGHT CLASS A*	x	I 0,30	J 0,44	K 0,44	L 0,30
	y	0,34	0,43	0,38	0,28
GREEN LIGHT CLASS A*	x	M 0,01	N 0,28	O 0,21	P 0,03
	y	0,72	0,52	0,40	0,40
BLUE LIGHT CLASS A*	x	Q 0,11	R 0,17	S 0,21	T 0,15
	y	0,09	0,16	0,13	0,03
ORANGE LIGHT	x	E 0,57	F 0,61	G 0,54	H 0,51
	y	0,43	0,39	0,38	0,41

**The standard areas have been restricted in order to include defective colour vision people*

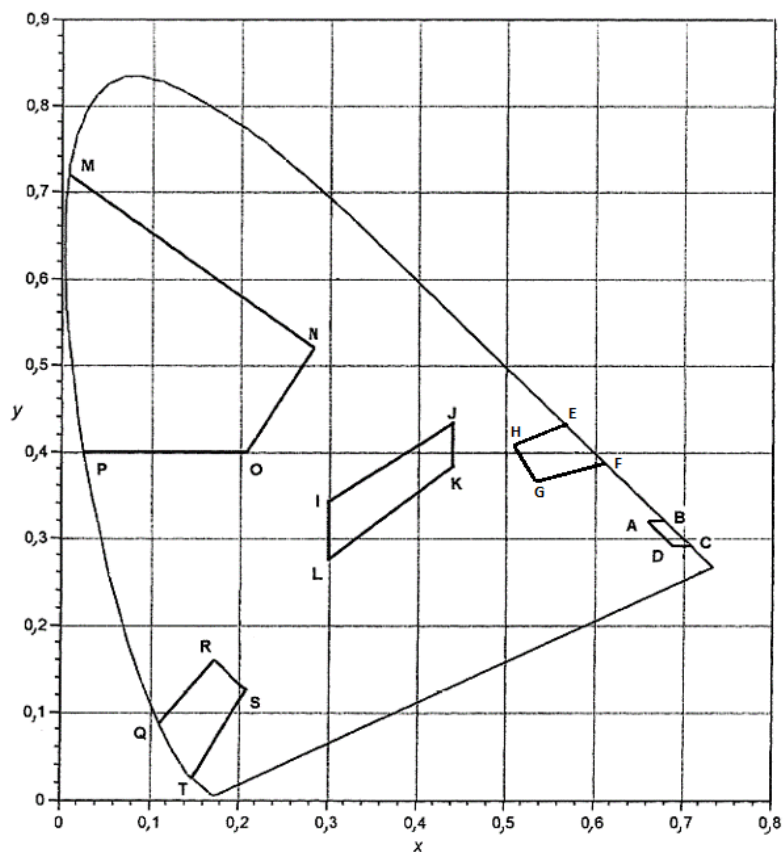

UNECE R48 Extract:

"Selective-yellow" means the chromaticity coordinates (x,y)⁴ of the light emitted that lie inside the chromaticity areas defined by the boundaries:

SY12	green boundary	$y = 1.290 x - 0.100$
SY23	the spectral locus	
SY34	red boundary	$y = 0.138 + 0.580 x$
SY45	yellowish white boundary	$y = 0.440$
SY51	white boundary	$y = 0.940 - x$

With intersection points:



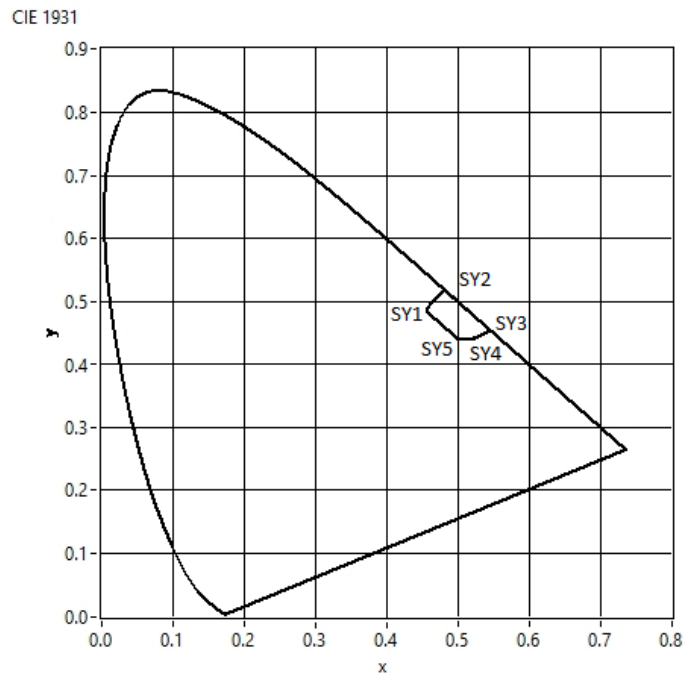







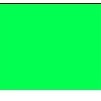

	x	y
SY1	0.454	0.486
SY2	0.480	0.519
SY3	0.545	0.454
SY4	0.521	0.440
SY5	0.500	0.440











Further information can be found on the UNECE website:

<http://www.unece.org/fileadmin/DAM/trans/main/wp29/wp29regs/2015/R048r12e.pdf>

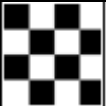
APPENDIX 2. FLAG DISPLAY MODES

FLAG TYPE	CURRENT DESIGN	RECOMMENDED FLASHING FREQUENCY (Hz)
Yellow		2
Double Yellow		2-4
White		2
Green		2
Blue		2
Red		2
Slippery Surface		Static
Safety Car		2
Virtual Safety Car		2
Full Course Yellow		2
Code 60		Static - 2
Pit Entry		Static
Pit Entry Closed		Static
Custom Blue		2

Standing / Rolling Start		2
Mechanical Problem		2-3
Unsportsmanlike behaviour		2-3
Black		2-3
Chequered Flag		2
Next Slow		2
Slow Zone		2
Rain (FIM)		Static
Rain + Slippery (FIM)		Static